

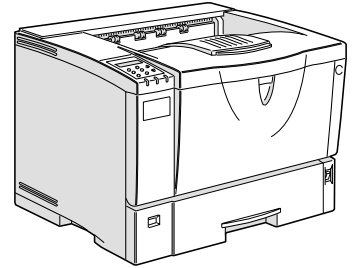

# Operating Instructions Printer Reference



- 
- 1** Setting Up the Printer Driver and Canceling a Print Job
  - 2** Uninstalling the Printer Driver and Software
  - 3** Paper and Other Media
  - 4** Sample Print/Locked Print
  - 5** Troubleshooting
  - 6** Making Printer Settings with the Control Panel
  - 7** Appendix

## **Introduction**

This manual describes detailed instructions on the operation and notes about the use of this machine. To get maximum versatility from this machine all operators are requested to read this manual carefully and follow the instructions. Please keep this manual in a handy place near the machine.

Please read "Safety Information" in the Setup Guide before using this machine. It contains important information related to USER SAFETY and PREVENTING EQUIPMENT PROBLEMS.

## **Important**

Contents of this manual are subject to change without prior notice. In no event will the company be liable for direct, indirect, special, incidental, or consequential damages as a result of handling or operating the machine.

### **Warning:**

Use of controls or adjustment or performance of procedures other than those specified in this manual might result in hazardous radiation exposure.

Do not attempt any maintenance or troubleshooting other than that mentioned in this manual. This printer contains a laser beam generator and direct exposure to laser beams can cause permanent eye damage.

For good print quality, the supplier recommends that you use genuine toner, maintenance kits and parts from the supplier.

The supplier shall not be responsible for any damage or expense that might result from the use of consumables (toner, maintenance kits and parts) other than genuine consumables from the supplier with your office products.

Two kinds of size notation are employed in this manual. With this machine refer to the metric version.

Some illustrations in this manual might be slightly different from the machine.

Certain options might not be available in some countries. For details, please contact your local dealer.

# TABLE OF CONTENTS

|                                       |          |
|---------------------------------------|----------|
| <b>Trademarks</b> .....               | <b>1</b> |
| <b>Manuals for This Printer</b> ..... | <b>2</b> |
| Manuals for This Printer .....        | 2        |
| <b>How to Read This Manual</b> .....  | <b>3</b> |

## 1. Setting Up the Printer Driver and Canceling a Print Job

---

|   |           |
|---|-----------|
| <b>PCL 6/5e - Accessing the Printer Properties</b> .....  | <b>5</b>  |
| Windows 95/98/Me - Accessing the Printer Properties .....   | 5         |
| Windows 2000/Windows XP/Server 2003 - Accessing the Printer Properties .....                            | 7         |
| Windows NT 4.0 - Accessing the Printer Properties .....   | 10        |
| <b>RPCS - Accessing the Printer Properties</b> .....  | <b>12</b> |
| Windows 95/98/Me - Accessing the Printer Properties .....   | 12        |
| Windows 2000/Windows XP/Server 2003 - Accessing the Printer Properties .....                            | 14        |
| Windows NT 4.0 - Accessing the Printer Properties .....   | 17        |
| <b>PostScript - Setting Up for Printing</b> .....   | <b>19</b> |
| Windows 95/98/Me - Accessing the Printer Properties .....   | 19        |
| Windows 2000/Windows XP/Server 2003 - Accessing the Printer Properties .....                            | 21        |
| Windows NT 4.0 - Accessing the Printer Properties .....   | 24        |
| Macintosh - Setting Up for Printing .....   | 26        |
| <b>Canceling a Print Job</b> .....  | <b>27</b> |
| Windows 95/98/Me, Windows 2000, Windows XP/Server 2003, Windows NT 4.0 -<br>Canceling a Print Job ..... | 27        |
| Macintosh - Canceling a Print Job .....   | 28        |

## 2. Uninstalling the Printer Driver and Software

---

|  |           |
|--|-----------|
| <b>Uninstalling the PCL 6/5e Printer Driver</b> .....                                | <b>31</b> |
| Windows 95/98/Me - Uninstalling the PCL 6/5e Printer Driver.....                     | 31        |
| Windows 2000/Windows XP/Server 2003 - Uninstalling the PCL 6/5e Printer Driver ...   | 31        |
| Windows NT 4.0 - Uninstalling the PCL 6/5e Printer Driver .....                      | 32        |
| <b>Uninstalling the RPCS Printer Driver</b> .....                                    | <b>33</b> |
| Windows 95/98/Me - Uninstalling the RPCS Printer Driver.....                         | 33        |
| Windows 2000/Windows XP/Server 2003 - Uninstalling the RPCS Printer Driver...        | 33        |
| Windows NT 4.0 - Uninstalling the RPCS Printer Driver.....                           | 34        |
| <b>Uninstalling the PostScript Printer Driver</b> .....                              | <b>35</b> |
| Windows 95/98/Me - Uninstalling the PostScript Printer Driver .....                  | 35        |
| Windows 2000/Windows XP/Server 2003 - Uninstalling the PostScript Printer Driver ... | 35        |
| Windows NT 4.0 - Uninstalling the PostScript Printer Driver .....                    | 36        |
| Macintosh - Uninstalling the PostScript Printer Driver .....                         | 36        |

### 3. Paper and Other Media

---

|   |           |
|---|-----------|
| <b>Paper and Other Media Supported by This Printer.....</b> | <b>37</b> |
| Paper Types and Sizes .....                                 | 37        |
| Paper Recommendations.....                                  | 44        |
| Printable Area .....  | 48        |
| <b>Loading Paper and Other Media.....</b>                   | <b>49</b> |
| Loading Paper in the Paper Tray .....                       | 49        |
| Loading Paper in the Bypass Tray .....                      | 52        |
| Loading Paper in the Optional Paper Tray .....              | 57        |
| Loading Envelopes.....                                      | 58        |

### 4. Sample Print/Locked Print

---

|                                      |           |
|--------------------------------------|-----------|
| <b>Sample Print.....</b>             | <b>63</b> |
| Printing a Sample Print File.....    | 64        |
| Deleting a Sample Print File.....    | 66        |
| Checking the Error Log .....         | 67        |
| <b>Locked Print .....</b>            | <b>68</b> |
| Printing a Locked Print File .....   | 69        |
| Deleting the Locked Print File ..... | 71        |
| Checking the Error Log .....         | 72        |

### 5. Troubleshooting

---

|   |            |
|---|------------|
| <b>Error &amp; Status Messages on the Control Panel .....</b>     | <b>75</b>  |
| Getting Printer Information over the Network.....                 | 86         |
| <b>Printer Does Not Print .....</b>                               | <b>93</b>  |
| <b>Other Printing Problems .....</b>                              | <b>97</b>  |
| <b>Removing Misfed Paper .....</b>                                | <b>101</b> |
| When "Remove Misfeed Paper Tray" Appears .....                    | 102        |
| When "Remove Misfeed Internal Path/Open Front Cover" Appears..... | 102        |
| When "Remove Misfeed Paper Exit Cover" Appears.....               | 104        |
| When "Remove Misfeed Duplex Unit" Appears .....                   | 106        |
| When "Remove Misfeed Mailbox" Appears .....                       | 108        |
| When "Remove Misfeed Upper Tray Unit" Appears .....               | 109        |
| <b>Replacing the Toner Cartridge .....</b>                        | <b>110</b> |
| <b>Cleaning and Adjusting the Printer.....</b>                    | <b>113</b> |
| Cleaning the Friction Pad.....                                    | 113        |
| Cleaning the Paper Feed Roller.....                               | 114        |
| Cleaning the Registration Roller .....                            | 116        |
| Adjusting the Image Density .....                                 | 117        |
| Adjusting the Registration of the Trays .....                     | 118        |

## 6. Making Printer Settings with the Control Panel

---

|   |            |
|---|------------|
| <b>Menu Chart</b> .....                             | <b>121</b> |
| <b>Accessing the Main Menu</b> .....                | <b>124</b> |
| <b>Paper Input Menu</b> .....                       | <b>126</b> |
| Paper Input Parameters .....                        | 126        |
| Changing the Paper Input Menu .....                 | 128        |
| <b>List/Test Print Menu</b> .....                   | <b>130</b> |
| List/Test Print Parameters .....                    | 130        |
| Printing the Configuration Page and Error Log ..... | 131        |
| Printing a Configuration Page .....                 | 133        |
| Interpreting the Configuration Page .....           | 135        |
| <b>Maintenance Menu</b> .....                       | <b>137</b> |
| Maintenance Menu Parameters .....                   | 137        |
| Changing the Maintenance Menu .....                 | 140        |
| <b>System Menu</b> .....                            | <b>148</b> |
| System Parameters .....                             | 148        |
| Changing the System Menu .....                      | 154        |
| <b>Host Interface Menu</b> .....                    | <b>156</b> |
| Host Interface Parameters .....                     | 156        |
| Changing the Host Interface Menu .....              | 161        |
| <b>PCL Menu</b> .....                               | <b>164</b> |
| PCL Parameters .....                                | 164        |
| Changing the PCL Menu .....                         | 166        |
| <b>PS Menu</b> .....                                | <b>168</b> |
| PS Parameters .....                                 | 168        |
| Changing the PS Menu .....                          | 169        |
| <b>PDF Menu</b> .....                               | <b>171</b> |
| PDF Parameters .....                                | 171        |
| Changing the PDF Menu .....                         | 172        |
| <b>Language Menu</b> .....                          | <b>174</b> |
| Changing the Language Menu .....                    | 174        |

## 7. Appendix

---

|   |            |
|---|------------|
| <b>Replacing Parts</b> .....                            | <b>177</b> |
| MAINTENANCE KIT Type 600 .....                          | 178        |
| Replacing the Friction Pad .....                        | 180        |
| Replacing the Paper Feed Rollers .....                  | 181        |
| Replacing the Transfer Roller .....                     | 183        |
| Replacing the Fusing Unit .....                         | 185        |
| <b>Collate and Shift Collate</b> .....                  | <b>187</b> |
| <b>Spool Printing</b> .....                             | <b>188</b> |
| <b>Precautions when using Windows Server 2003</b> ..... | <b>189</b> |
| Precautions when using the Terminal Server mode .....   | 189        |
| <b>Memory Capacity and Paper Size</b> .....             | <b>190</b> |
| Setting of the “Frame Priority” .....                   | 190        |
| Setting of the “Font Priority” .....                    | 192        |
| <b>Moving and Transporting the Printer</b> .....        | <b>194</b> |
| Moving the Printer .....                                | 194        |
| <b>Specifications</b> .....                             | <b>196</b> |
| Mainframe .....   | 196        |
| Options .....   | 199        |
| <b>Consumables</b> .....                                | <b>204</b> |
| <b>Information about Installed Software</b> .....       | <b>205</b> |
| expat .....   | 205        |
| JPEG LIBRARY .....                                      | 205        |
| NetBSD .....  | 205        |
| <b>INDEX</b> .....                                      | <b>208</b> |

# Trademarks

AppleTalk, EtherTalk, LaserWriter, Macintosh are registered trademarks of Apple Computer, Inc.

Ethernet is a registered trademark of Xerox Corporation.

Microsoft, Windows, Windows NT are registered trademarks of Microsoft Corporation in the United States and/or other countries.

Novell, NetWare are registered trademarks of Novell, Inc.

PostScript is a registered trademark of Adobe Systems, Incorporated.

PowerPC is a registered trademark of International Business Machines Corporation.

PCL is a registered trademark of Hewlett-Packard Company.

Bluetooth is a Trademark of the Bluetooth SIG, Inc. (Special Interest Group) and licensed to RICOH Company Limited.

Copyright Copier 2001 Bluetooth SIG, Inc.

The Bluetooth Trademarks are owned by Bluetooth SIG, Inc. USA

Other product names used herein are for identification purposes only and might be trademarks of their respective companies. We disclaim any and all rights in those marks.

The proper names of the Windows operating systems are as follows:

- The product name of Windows<sup>®</sup> 95 is Microsoft<sup>®</sup> Windows 95.
- The product name of Windows<sup>®</sup> 98 is Microsoft<sup>®</sup> Windows 98.
- The product name of Windows<sup>®</sup> Me is Microsoft<sup>®</sup> Windows Millennium Edition (Windows Me).
- The product names of Windows<sup>®</sup> 2000 are as follows:
  - Microsoft<sup>®</sup> Windows<sup>®</sup> 2000 Advanced Server
  - Microsoft<sup>®</sup> Windows<sup>®</sup> 2000 Server
  - Microsoft<sup>®</sup> Windows<sup>®</sup> 2000 Professional
- The product names of Windows<sup>®</sup> XP are as follows:
  - Microsoft<sup>®</sup> Windows<sup>®</sup> XP Professional
  - Microsoft<sup>®</sup> Windows<sup>®</sup> XP Home Edition
- The product names of Windows Server<sup>™</sup> 2003 are as follows:
  - Microsoft<sup>®</sup> Windows Server<sup>™</sup> 2003 Standard Edition
  - Microsoft<sup>®</sup> Windows Server<sup>™</sup> 2003 Enterprise Edition
  - Microsoft<sup>®</sup> Windows Server<sup>™</sup> 2003 Web Edition
- The product names of Windows NT<sup>®</sup> 4.0 are as follows:
  - Microsoft<sup>®</sup> Windows NT<sup>®</sup> Server 4.0
- Microsoft<sup>®</sup> Windows NT<sup>®</sup> Workstation 4.0

# Manuals for This Printer

---

## Manuals for This Printer

---

The following manuals describe the operational procedures and maintenance of this machine.

To enhance safe and efficient operation of this printer, all users should read and follow the instructions carefully.

❖ **Quick Installation Guide**

Describes how to install the printer.

❖ **Setup Guide**

Provides information about setting up the printer and its options. This manual is provided as a printed manual, and also on the CD-ROM labeled "Operating Instructions".

❖ **Printer Reference (this manual)**

Provides information about using the printer and its options. This manual provided on the CD-ROM labeled "Operating Instructions".

❖ **Network Printing Guide**

Provides information about setting up and using the printer in a network environment. This manual provided on the CD-ROM labeled "Operating Instructions".

❖ **PostScript 3 Operating Instructions Supplement**

Describes the menus and features for the PostScript 3 printer driver. This manual provided on the CD-ROM labeled "Operating Instructions".

 **Note**

- ❑ There are three CD-ROMs that come with this printer. "Operating Instructions", "Printer Drivers and Utilities", and "Document Management Utility".
- ❑ Concerning UNIX information, please visit our Web site or consult your authorized reseller.



# How to Read This Manual

---

## Symbols

---

In this manual, the following symbols are used:

 **WARNING:**

This symbol indicates a potentially hazardous situation which, if instructions are not followed, could result in death or serious injury.

 **CAUTION:**

This symbol indicates a potentially hazardous situation which, if instructions are not followed, may result in minor or moderate injury or damage to property.

\* The statements above are notes for your safety.

 **Important**

If this instruction is not followed, paper might be misfed, originals might be damaged, or data might be lost. Be sure to read this.

 **Preparation**

This symbol indicates the prior knowledge or preparations required before operating.

 **Note**

This symbol indicates precautions for operation, or actions to take after misoperation.

 **Limitation**

This symbol indicates numerical limits, functions that cannot be used together, or conditions in which a particular function cannot be used.

 **Reference**

This symbol indicates a reference.

[    ]

Keys that appear on the machine's panel display.

Keys and buttons that appear on the computer's display.

[    ]

Keys built into the machine's control panel.

Keys on the computer's keyboard.



# 1. Setting Up the Printer Driver and Canceling a Print Job

## PCL 6/5e - Accessing the Printer Properties

---

### Windows 95/98/Me - Accessing the Printer Properties

---

There are two methods you can use to open the printer properties dialog box.

---

#### Changing the default printer settings

---

##### **Note**

- With some applications, the printer driver's settings are not used, and the application's own default settings are applied.

**1** Click **[Start]** on the taskbar, point to **[Settings]**, and then click **[Printers]**.

The **[Printers]** window appears.

**2** Click to select the icon of the printer whose default settings you want to change.

**3** On the **[File]** menu, click **[Properties]**.

The Printer Properties appear.

**4** Make any settings you require and click **[Apply]**.

**5** Click **[OK]**.

---

#### **If a message is displayed during printer driver installation**

When there is a driver in the computer that is newer than the one currently being installed, a message dialog box appears.

If this happens, you cannot install using the Auto Run program. Use the driver displayed in the message, and reinstall using **[Add Printer]**.

① Click **[Start]**, point to **[Settings]**, and then click **[Printers]**.

② Double-click the **[Add Printer]** icon.

③ Follow the wizard to install the driver.

If the printer driver is stored on a CD-ROM, the source for installation is as follows: (If the installer starts up, click **[Cancel]** to quit it.)

- PCL 6  
DRIVERS\PCL6\WIN9X\_ME\ (Language) \DISK1
  - PCL 5e  
DRIVERS\PCL5e\WIN9X\_ME\ (Language) \DISK1
-

---

## Making printer settings from an application

---

To make the printer settings for a specific application, open the **[Printer Properties]** dialog box from that application. The following example describes how to make settings for the WordPad application that comes with Windows 95/98/Me.

### **Note**

- The actual procedure you should follow to open the **[Printer Properties]** dialog box may differ depending on the application. For more information, see the documentation that comes with the application you are using.
- With some applications, the printer driver's settings are not used, and the application's own default settings are applied.
- Any settings you make in the following procedure are valid for the current application only.

**1** On the **[File]** menu, click **[Print]**.

The **[Print]** dialog box appears.

**2** Select the printer you want to use in the **[Name]** list box, and then click **[Properties]**.

The **[Printer Properties]** dialog box appears.

**3** Make any settings you require and click **[OK]**.

**4** Click **[OK]** to start printing.

---

# Windows 2000/Windows XP/Server 2003 - Accessing the Printer Properties

---

---

## Changing the default printer settings - Printer Properties

---

1

### Limitation

- Changing the setting of the printer requires Manage Printers permission. Members of the Administrators and Power Users groups have Manage Printers permission by default. When you set up options, log on using an account that has Manage Printers permission.

### **1** Click **[Start]** on the taskbar, point to **[Settings]**, and then click **[Printers]**.

The **[Printers]** window appears.

#### Note

- With Windows XP Professional/Windows Server 2003, access the **[Printers and Faxes]** window from **[Start]** on the taskbar.
- With Windows XP Home Edition, open **[Control panel]** from **[Start]**, click **[Printers and Other Hardware]**, and then click **[Printers and Faxes]** on the screen that appears.

### **2** Click to select the icon of the printer whose default setting you want to change.

### **3** On the **[File]** menu, click **[Properties]**.

The Printer Properties appear.

#### Note

- When you open the printer properties dialog box for the first time after installing the RPCS printer driver, a confirmation window appears. After that, the initial display of the printer properties dialog box appears.

### **4** Make any settings you require and click **[OK]**.

#### Note

- Settings you make here are used as the default settings for all applications.

### **5** Click **[OK]**.

 **If a message is displayed during printer driver installation**

When there is a driver in the computer that is newer than the one currently being installed, a message dialog box appears.

If this happens, you cannot install using the Auto Run program. Use the driver displayed in the message, and reinstall using **[Add Printer]**.

- ① Click **[Start]**, point to **[Settings]**, and then click **[Printers]**.
- ② Double-click the **[Add Printer]** icon.
- ③ Follow the wizard to install the driver.

If the printer driver is stored on a CD-ROM, the source for installation is as follows: (If the installer starts up, click **[Cancel]** to quit it.)

- PCL 6  
DRIVERS\PCL6\WIN2K\_XP\ (Language) \DISK1
- PCL 5e  
DRIVERS\PCL5e\WIN2K\_XP\ (Language) \DISK1

---

## Changing the default printer settings – Printing Preferences Properties

---

 **Limitation**

- Changing the setting of the printer requires Manage Printers permission. Members of the Administrators and Power Users groups have Manage Printers permission by default. When you set up options, log on using an account that has Manage Printers permission.

- 1** Click **[Start]** on the taskbar, point to **[Settings]**, and then click **[Printers]**.

The **[Printers]** window appears.

- 2** Click to select the icon of the printer whose default settings you want to change.

- 3** On the **[File]** menu, click **[Printing Preferences...]**.

The Printing Preferences Properties appears.

- 4** Make any settings you require and click **[Apply]**.

 **Note**

- Settings you make here are used as the default settings for all applications.

- 5** Click **[OK]**.

---

## Making printer settings from an application

---

To make the printer settings for a specific application, open the **[Print]** dialog box from that application. The following example describes how to make settings for the WordPad application that comes with Windows 2000/Windows XP/Server 2003.

 **Note**

- The actual procedures you should follow to open the **[Print]** dialog box may differ depending on the application. For more information, see the documentation that comes with the application you are using.
- Any settings you make in the following procedure are valid for the current application only.

**1** On the **[File]** menu, click **[Print...]**.

The **[Print]** dialog box appears.

**2** Select the printer you want to use in the **[Select Printer]** box.

Click the tab that you want to change its print setting.

 **Note**

- With Windows XP/Server 2003, click **[Preference]** to open the Printer Preference window.

**3** Make any settings you require and click **[Apply]**.

 **Note**

- With Windows XP/Server 2003, make any settings you require and click **[OK]**.

**4** Click **[Print]** to start printing.

---

## Windows NT 4.0 - Accessing the Printer Properties

---

1

---

### Changing the default printer settings - Printer Properties

---

#### Limitation

- Changing the setting of the printer requires Full Control access permission. Members of Administrators, Server Operators, Print Operators, and Power Users groups have Full Control permission by default. When you set up options, log on using an account that has Full Control permission.

**1** Click **[Start]** on the taskbar, point to **[Settings]**, and then click **[Printers]**.

The **[Printers]** window appears.

#### Note

- When you open the printer properties dialog box for the first time after installing the RPCS printer driver, a confirmation window appears. After that, the initial display of the printer properties dialog box appears.

**2** Click to select the icon of the printer whose default settings you want to change.

**3** On the **[File]** menu, click **[Properties]**.

The Printer Properties appears.

**4** Make any settings you require and click **[OK]**.

#### Note

- Settings you make here are used as the default settings for all applications.

---

#### If a message is displayed during printer driver installation

When there is a driver in the computer that is newer than the one currently being installed, a message dialog box appears.

If this happens, you cannot install using the Auto Run program. Use the driver displayed in the message, and reinstall using **[Add Printer]**.

① Click **[Start]**, point to **[Settings]**, and then click **[Printers]**.

② Double-click the **[Add Printer]** icon.

③ Follow the wizard to install the driver.

If the printer driver is stored on a CD-ROM, the source for installation is as follows: (If the installer starts up, click **[Cancel]** to quit it.)

- PCL 6  
DRIVERS\PCL6\NT4\ (Language) \DISK1
- PCL 5e  
DRIVERS\PCL5e\NT4\ (Language) \DISK1



---

## Changing the default printer settings – Default Document Properties

---

### Limitation

- Changing the setting of the printer requires Full Control access permission. Members of the Administrators, Server Operators, Print Operators, and Power Users groups have Full Control permission by default. When you set up options, log on using an account that has Full Control permission.

### **1** Click **[Start]** on the taskbar, point to **[Settings]**, and then click **[Printers]**.

The **[Printers]** window appears.

### **2** Click to select the icon of the printer whose default settings you want to change.

### **3** On the **[File]** menu, click **[Document Defaults]**.

The Default Document Properties appear.

### **4** Make any settings you require and click **[OK]**.

#### Note

- Settings you make here are used as the default settings for all applications.

---

## Making printer settings from an application

---

To make the printer settings for a specific application, open the **[Printer Properties]** dialog box from that application. The following example describes how to make settings for the WordPad application that comes with Windows NT 4.0.

#### Note

- The actual procedure you should follow to open the **[Printer Properties]** dialog box may differ depending on the application. For more information, see the documentation that comes with the application you are using.
- Any settings you make in the following procedure are valid for the current application only.

### **1** On the **[File]** menu, click **[Print]**.

The **[Print]** dialog box appears.

### **2** Select the printer you want to use in the **[Name]** list box, and then click **[Properties]**.

The Printer Properties appears.

### **3** Make any settings you require and click **[OK]**.

Click **[OK]** to start printing.

# RPCS - Accessing the Printer Properties

1

---

## Windows 95/98/Me - Accessing the Printer Properties

---

There are two windows types you can use to open the printer properties dialog box.

“Multi-tab” is used as an example in this manual. See Help for information about changing the windows types.

### ❖ Multi-tab

This is the window type for users who often change print settings in order to make various kinds of prints.

### ❖ Custom Setting

This is the window type for users who rarely change print settings when making prints. The Custom Setting display may vary depending on the installed options.

---

## Changing the default printer settings

---

To make default printer settings, first open the printer properties dialog box from the **[Printers]** window.

### Note

- With some applications, printer driver settings are not used, and the application's own default settings are applied.

**1** Click **[Start]** on the taskbar, point to **[Settings]**, and then click **[Printers]**.

The **[Printers]** window appears.

**2** Click to select the icon of the printer whose default settings you want to change.

**3** On the **[File]** menu, click **[Properties]**.

The printer properties appear.

### Note

- When you open the printer properties dialog box for the first time after installing the RPCS printer driver, a confirmation window appears. After that, the initial display of the printer properties dialog box appears.

**4** Make any settings you require and click **[Apply]**.

### Note

- With some applications, the printer driver's settings are not used, and the application's own default settings are applied.

**5** Click **[OK]**.

### If a message is displayed during printer driver installation

When there is a driver in the computer that is newer than the one currently being installed, a message dialog box appears.

If this happens, you cannot install using the Auto Run program. Use the driver displayed in the message, and reinstall using **[Add Printer]**.

- ① Click **[Start]**, point to **[Settings]**, and then click **[Printers]**.
- ② Double-click the **[Add Printer]** icon.
- ③ Follow the wizard to install the driver.

If the printer driver is stored on a CD-ROM, the source for installation is as follows: (If the installer starts up, click **[Cancel]** to quit it.)

- RPCS  
   DRIVERS\RPCS\WIN9X\_ME\ (Language) \DISK1

---

### Making printer settings from an application

---

To make the printer settings for a specific application, open the **[Printer Properties]** dialog box from that application. The following example describes how to make settings for the WordPad application that comes with Windows 95/98/Me.

#### Note

- The actual procedure you should follow to open the **[Printer Properties]** dialog box may differ depending on the application. For more information, see the documentation that comes with the application you are using.
- With some applications, printer driver settings are not used, and the application's own default settings are applied.
- Any settings you make in the following procedure are valid for the current application only.

#### **1** On the **[File]** menu, click **[Print]**.

The **[Print]** dialog box appears.

#### **2** Select the printer you want to use in the **[Name]** list box, and then click **[Properties]**.

The **[Printer Properties]** dialog box appears.

#### **3** Make any settings you require and click **[OK]**.

#### **4** Click **[OK]** to start printing.

---

## Windows 2000/Windows XP/Server 2003 - Accessing the Printer Properties

---

1

---

### Changing the default printer settings - Printer Properties

---

#### **Limitation**

- Changing the setting of the printer requires Manage Printers permission. Members of the Administrators and Power Users groups have Manage Printers permission by default. When you set up options, log on using an account that has Manage Printers permission.

#### **1** Click **[Start]** on the taskbar, point to **[Settings]**, and then click **[Printers]**.

The **[Printers]** window appears.

#### **Note**

- With Windows XP Professional/Windows Server 2003, access the **[Printers and Faxes]** window from **[Start]** on the taskbar.
- With Windows XP Home Edition, open **[Control panel]** from **[Start]**, click **[Printers and Other Hardware]**, and then click **[Printers and Faxes]** on the screen that appears.

#### **2** Click to select the icon of the printer whose default settings you want to change.

#### **3** On the **[File]** menu, click **[Properties]**.

The Printer Properties appears.

#### **Note**

- When you open the printer properties dialog box for the first time after installing the RPCS printer driver, a confirmation window appears. After that, the initial display of the printer properties dialog box appears.

#### **4** Make any settings you require and click **[Apply]**.

#### **Note**

- Settings you make here are used as the default settings for all applications.

#### **5** Click **[OK]**.

### If a message is displayed during printer driver installation

When there is a driver in the computer that is newer than the one currently being installed, a message dialog box appears.

If this happens, you cannot install using the Auto Run program. Use the driver displayed in the message, and reinstall using **[Add Printer]**.

- ① Click **[Start]**, point to **[Settings]**, and then click **[Printers]**.
- ② Double-click the **[Add Printer]** icon.
- ③ Follow the wizard to install the driver.

If the printer driver is stored on a CD-ROM, the source for installation is as follows: (If the installer starts up, click **[Cancel]** to quit it.)

- RPCS  
   DRIVERS\RPCS\WIN2K\_XP\ (Language) \DISK1

---

## Changing the default printer settings – Printing Preferences Properties

---

### Limitation

- Changing the setting of the printer requires Manage Printers permission. Members of the Administrators and Power Users groups have Manage Printers permission by default. When you set up options, log on using an account that has Manage Printers permission.

- 1** Click **[Start]** on the taskbar, point to **[Settings]**, and then click **[Printers]**.

The **[Printers]** window appears.

- 2** Click to select the icon of the printer whose default settings you want to change.

- 3** On the **[File]** menu, click **[Printing Preferences...]**.

The Printing Preferences Properties appear.

- 4** Make any settings you require and click **[Apply]**.

### Note

- Settings you make here are used as the default settings for all applications.

- 5** Click **[OK]**.

---

## Making printer settings from an application

---

To make the printer settings for a specific application, open the **[Print]** dialog box from that application. The following example describes how to make settings for the WordPad application that comes with Windows 2000.

 **Note**

- The actual procedures you should follow to open the **[Print]** dialog box may differ depending on the application. For more information, see the documentation that comes with the application you are using.
- Any settings you make in the following procedure are valid for the current application only.

**1** On the **[File]** menu, click **[Print...]**.

The **[Print]** dialog box appears.

**2** Select the printer you want to use in the **[Select Printer]** box.

Click the tab that you want to change its print setting.

 **Note**

- With Windows XP/Server 2003, click **[Preference]** to open the Printer Preference window.

**3** Make any settings you require and click **[Apply]**.

 **Note**

- With Windows XP/Server 2003, make any settings you require and click **[OK]**.

**4** Click **[Print]** to start printing.

## Windows NT 4.0 - Accessing the Printer Properties

### Changing the default printer settings - Printer Properties

1

#### Limitation

- Changing the setting of the printer requires Full Control access permission. Members of Administrators, Server Operators, Print Operators, and Power Users groups have Full Control permission by default. When you set up options, log on using an account that has Full Control permission.

#### **1** Click **[Start]** on the taskbar, point to **[Settings]**, and then click **[Printers]**.

The **[Printers]** window appears.

#### **2** Click to select the icon of the printer you want to use.

#### **3** On the **[File]** menu, click **[Properties]**.

The **[Printer Properties]** dialog box appears.

#### Note

- When you open the printer properties dialog box for the first time after installing the RPCS printer driver, a confirmation window appears. After that, the initial display of the printer properties dialog box appears.

#### **4** Make any settings you require and click **[OK]**.

#### Note

- Settings you make here are used as the default settings for all applications.

#### If a message is displayed during printer driver installation

When there is a driver in the computer that is newer than the one currently being installed, a message dialog box appears.

If this happens, you cannot install using the Auto Run program. Use the driver displayed in the message, and reinstall using **[Add Printer]**.

#### ① Click **[Start]**, point to **[Settings]**, and then click **[Printers]**.

#### ② Double-click the **[Add Printer]** icon.

#### ③ Follow the wizard to install the driver.

If the printer driver is stored on a CD-ROM, the source for installation is as follows: (If the installer starts up, click **[Cancel]** to quit it.)

- RPCS  
`DRIVERS\RPCS\NT4 \ (Language) \DISK1`

---

## Changing the default printer settings – Default Document Properties

---

### Limitation

- Changing the setting of the printer requires Full Control access permission. Members of the Administrators, Server Operators, Print Operators, and Power Users groups have Full Control permission by default. When you set up options, log on using an account that has Full Control permission.

**1** Click **[Start]** on the taskbar, point to **[Settings]**, and then click **[Printers]**.

The **[Printers]** window appears.

**2** Click to select the icon of the printer you want to use.

**3** On the **[File]** menu, click **[Document Defaults]**.

The Default Document Properties appear.

**4** Make any settings you require and click **[OK]**.

### Note

- Settings you make here are used as the default settings for all applications.

---

## Making printer settings from an application

---

To make the printer settings for a specific application, open the **[Printer Properties]** dialog box from that application. The following example describes how to make settings for the WordPad application that comes with Windows NT 4.0.

### Note

- The actual procedure you should follow to open the **[Printer Properties]** dialog box may differ depending on the application. For more information, see the documentation that comes with the application you are using.
- With some applications, printer driver settings are not used, and the application's own default settings are applied.
- Any settings you make in the following procedure are valid for the current application only.

**1** On the **[File]** menu, click **[Print]**.

The **[Print]** dialog box appears.

**2** Select the printer you want to use in the **[Name]** list box, and then click **[Properties]**.

The **[Printer Properties]** dialog box appears.

**3** Make any settings you require and click **[OK]**.

**4** Click **[OK]** to start printing.



# PostScript - Setting Up for Printing

## Windows 95/98/Me - Accessing the Printer Properties

There are two methods you can use to open the printer properties dialog box.

### Changing the default printer settings

To make default printer settings, first open the printer properties dialog box from the **[Printers]** window.

#### Note

- With some applications, the printer driver's settings are not used, and the application's own default settings are applied.

**1** Click **[Start]** on the taskbar, point to **[Settings]**, and then click **[Printers]**.

The **[Printers]** window appears.

**2** Click to select the icon of the printer whose default settings you want to change.

**3** On the **[File]** menu, click **[Properties]**.

The **[Printer Properties]** dialog box appears.

**4** Make any settings you require and click **[Apply]**.

**5** Click **[OK]**.

#### If a message is displayed during printer driver installation

When there is a driver in the computer that is newer than the one currently being installed, a message dialog box appears.

If this happens, you cannot install using the Auto Run program. Use the driver displayed in the message, and reinstall using **[Add Printer]**.

① Click **[Start]**, point to **[Settings]**, and then click **[Printers]**.

② Double-click the **[Add Printer]** icon.

③ Follow the wizard to install the driver.

If the printer driver is stored on a CD-ROM, the source for installation is as follows: (If the installer starts up, click **[Cancel]** to quit it.)

- PostScript 3  
`DRIVERS\PS\WIN9X_ME\ (Language) \DISK1`

---

## Making printer settings from an application

---

To make the printer settings for a specific application, open the **[Printer Properties]** dialog box from that application. The following example describes how to make settings for the WordPad application that comes with Windows 95/98/Me.

 **Note**

- The actual procedure you should follow to open the **[Printer Properties]** dialog box may differ depending on the application. For more information, see the documentation that comes with the application you are using.
- With some applications, printer driver settings are not used, and the application's own default settings are applied.
- Any settings you make in the following procedure are valid for the current application only.

**1** On the **[File]** menu, click **[Print]**.

The **[Print]** dialog box appears.

**2** Select the printer you want to use in the Name list box, and then click **[Properties]**.

The **[Printer Properties]** dialog box appears.

**3** Make any settings you require and click **[Apply]**.

**4** Click **[OK]** to start printing.

---

## Windows 2000/Windows XP/Server 2003 - Accessing the Printer Properties

---

---

### Changing the default printer settings - Printer Properties

---

1

#### Limitation

- Changing the setting of the printer requires Manage Printers permission. Members of the Administrators and Power Users groups have Manage Printers permission by default. When you set up options, log on using an account that has Manage Printers permission.

#### **1** Click **[Start]** on the taskbar, point to **[Settings]**, and then click **[Printers]**.

The **[Printers]** window appears.

#### Note

- With Windows XP Professional/Windows Server 2003, access the **[Printers and Faxes]** window from **[Start]** on the taskbar.
- With Windows XP Home Edition, open **[Control panel]** from **[Start]**, click **[Printers and Other Hardware]**, and then click **[Printers and Faxes]** on the screen that appears.

#### **2** Click to select the icon of the printer whose default settings you want to change.

#### **3** On the **[File]** menu, click **[Properties]**.

The Printer Properties appear.

#### **4** Make any settings you require and click **[Apply]**.

#### Note

- Settings you make here are used as the default settings for all applications.

#### **5** Click **[OK]**.

 **If a message is displayed during printer driver installation**

When there is a driver in the computer that is newer than the one currently being installed, a message dialog box appears.

If this happens, you cannot install using the Auto Run program. Use the driver displayed in the message, and reinstall using **[Add Printer]**.

- ① Click **[Start]**, point to **[Settings]**, and then click **[Printers]**.
- ② Double-click the **[Add Printer]** icon.
- ③ Follow the wizard to install the driver.

If the printer driver is stored on a CD-ROM, the source for installation is as follows: (If the installer starts up, click **[Cancel]** to quit it.)

- PostScript 3  
    **DRIVERS\PS\WIN2K\_XP (Language) \DISK1**

---

## Changing the default printer settings – Printing Preferences Properties

---

 **Limitation**

- Changing the setting of the printer requires Manage Printers permission. Members of the Administrators and Power Users groups have Manage Printers permission by default. When you set up options, log on using an account that has Manage Printers permission.

- 1** Click **[Start]** on the taskbar, point to **[Settings]**, and then click **[Printers]**.

The **[Printers]** window appears.

- 2** Click to select the icon of the printer whose default settings you want to change.

- 3** On the **[File]** menu, click **[Printing Preferences...]**.

The Printing Preferences Properties appears.

- 4** Make any settings you require and click **[Apply]**.

 **Note**

- Settings you make here are used as the default settings for all applications.

- 5** Click **[OK]**.

---

## Making printer settings from an application

---

To make the printer settings for a specific application, open the **[Print]** dialog box from that application. The following example describes how to make settings for the WordPad application that comes with Windows 2000/Windows XP/Server 2003.

 **Note**

- The actual procedures you should follow to open the **[Print]** dialog box may differ depending on the application. For more information, see the documentation that comes with the application you are using.
- Any settings you make in the following procedure are valid for the current application only.

**1** On the **[File]** menu, click **[Print...]**.

The **[Print]** dialog box appears.

**2** Select the printer you want to use in the **[Select Printer]** box.

Click the tab that you want to change its print setting.

 **Note**

- With Windows XP/Server 2003, click **[Preference]** to open the Printer Preference window.

**3** Make any settings you require and click **[Apply]**.

**4** Click **[OK]** to start printing.

---

## Windows NT 4.0 - Accessing the Printer Properties

---

1

---

### Changing the default printer settings - Printer Properties

---

 **Limitation**

- Changing the setting of the printer requires Full Control access permission. Members of Administrators, Server Operators, Print Operators, and Power Users groups have Full Control permission by default. When you set up options, log on using an account that has Full Control permission.

**1** Click **[Start]** on the taskbar, point to **[Settings]**, and then click **[Printers]**.

The **[Printers]** window appears .

**2** Click to select the icon of the printer whose default settings you want to change.

**3** On the **[File]** menu, click **[Properties]**.

The **[Printer Properties]** dialog box appears.

**4** Make any settings you require and click **[OK]**.

 **Note**

- Setting you make here are used as the default settings for all applications.

---

 **If a message is displayed during printer driver installation**

When there is a driver in the computer that is newer than the one currently being installed, a message dialog box appears.

If this happens, you cannot install using the Auto Run program. Use the driver displayed in the message, and reinstall using **[Add Printer]**.

① Click **[Start]**, point to **[Settings]**, and then click **[Printers]**.

② Double-click the **[Add Printer]** icon.

③ Follow the wizard to install the driver.

If the printer driver is stored on a CD-ROM, the source for installation is as follows: (If the installer starts up, click **[Cancel]** to quit it.)

- PostScript 3  
    **DRIVERS\PS\NT4\ (Language) \DISK1**

---

## Changing the default printer settings - Default Document Properties

---

### Limitation

- Changing the setting of the printer requires Full Control access permission. Members of the Administrators, Server Operators, Print Operators, and Power Users groups have Full Control permission by default. When you set up options, log on using an account that has Full Control permission.

**1** Click **[Start]** on the taskbar, point to **[Settings]**, and then click **[Printers]**.

The **[Printers]** window appears.

**2** Click to select the icon of the printer you want to use.

**3** On the **[File]** menu, click **[Document Defaults]**.

The Default Document Properties appear.

**4** Make any settings you require and click **[OK]**.

### Note

- Settings you make here are used as the default settings for all applications.

---

## Making printer settings from an application

---

To make the printer settings for a specific application, open the **[Printer Properties]** dialog box from that application. The following example describes how to make settings for the WordPad application that comes with Windows NT 4.0.

### Note

- The actual procedure you should follow to open the **[Printer Properties]** dialog box may differ depending on the application. For more information, see the documentation that comes with the application you are using.
- With some applications, printer driver settings are not used, and the application's own default settings are applied.
- Any settings you make in the following procedure are valid for the current application only.

**1** On the **[File]** menu, click **[Print]**.

The **[Print]** dialog box appears.

**2** Select the printer you want to use in the **[Name]** list box, and then click **[Properties]**.

The **[Printer Properties]** dialog box appears.

**3** Make any settings you require and click **[OK]**.

**4** Click **[OK]** to start printing.

---

## Macintosh - Setting Up for Printing

---

1

---

### Making paper settings from an application

---

- 1** Open the file you want to print.
- 2** On the [File] menu, click [Page Setup].  
The [AdobePS Page Setup] dialog box appears.
- 3** Confirm that the printer you want to use is shown in the [Format for:] box.

 **Note**

- If the printer is not shown in the [Format for:] box, use the pop-up menu to display a list of available printers.

 **Reference**

The actual appearance of the Page Setup depends on the application you are using. See the documentation that comes with the Macintosh for more information.

- 4** From the [Paper:] <sup>\*1</sup> box, select the paper size.  
<sup>\*1</sup> Under Mac OS X, this is called [Paper Size].
- 5** Make any settings you require and then click [OK].

---

### Setting up for printing from an application

---

- 1** Open the file you want to print.
- 2** On the [File] menu, click [Print].  
The Printer Settings appears.
- 3** Confirm that the printer is selected in the [Printer :] box.
- 4** Make any settings you require and click [Print] to start printing.



# Canceling a Print Job

1

## Windows 95/98/Me, Windows 2000, Windows XP/Server 2003, Windows NT 4.0 - Canceling a Print Job

**1** Double-click the printer icon on the Windows taskbar.

A window appears, showing all the print jobs that are currently queuing to be printed. Check the current status of the job you want to cancel.

**2** Select the name of the job you want to cancel.

**3** On the [Document] menu, click [Cancel Printing].

 **Note**

You can also open the print job queue window by double-clicking the printer icon in the [Printer] window.

**4** Press [Job Reset] on the control panel.

"Job Reset?" appears on the panel display.

**5** Select between canceling the job currently printing and canceling all jobs (including the job currently printing) using [▲] or [▼].

- When canceling only the current job

```
Job Reset?
Current Job
```

- When canceling all jobs including the current job

```
Job Reset?
All Jobs
```

 **Note**

It is also possible to annul the cancellation. Resume printing is resumed by selecting "Resume Print", and then pressing [Enter #].

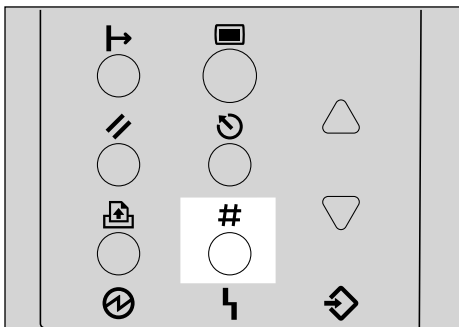
**6** Press **[Enter #]**.

ZKGS021E

A confirmation message appears.

**Note**

- Printing resumes if you press **[Escape]** at this point.

**7** Press **[Enter #]**.

The job is canceled. When the cancellation procedure is complete, the message appears.

**Important**

- When the printer is being shared by multiple computers, be careful not to accidentally cancel someone else's print job.

**Note**

- A print job that contains a large volume of data may take considerable time to stop.

---

## Macintosh - Canceling a Print Job

---

**1** Double-click the printer's icon on the desktop.

A window appears, showing all the print jobs that are currently queuing to be printed. Check the current status of the job you want to cancel.

**Note**

- Under Mac OS X, start Print Center.

**2** Select the name of the job you want to cancel.**3** Click the pause icon, and then click the trash icon.**4** Press **[Job Reset]** on the control panel.

"Job Reset?" appears on the panel display.

**5** Select between canceling the job currently printing and canceling all jobs (including the job currently printing) using **[▲]** or **[▼]**.

- When canceling only the current job

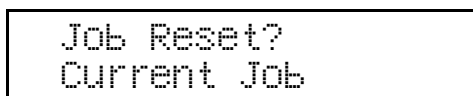

- When canceling all jobs including the current job

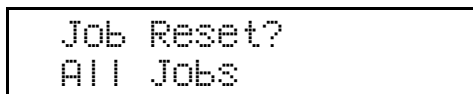

**Note**

- It is also possible to annul the cancellation. Resume printing is resumed by selecting "Resume Print", and then pressing **[Enter #]**.

**6** Press **[Enter #]**.

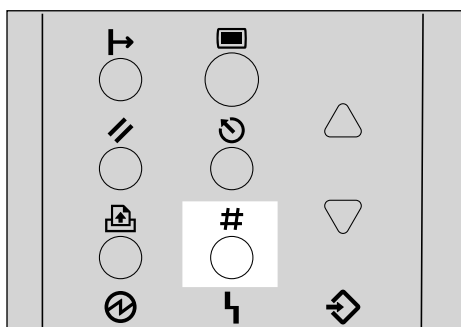

ZKGS021E

A confirmation message appears.

**Note**

- Printing resumes if you press **[Escape]** at this point.

**7** Press **[Enter #]**.

The job is canceled. When the cancellation procedure is complete, the message appears.

**Important**

- When the printer is being shared by multiple computers, be careful not to accidentally cancel someone else's print job.

**Note**

- A print job that contains a large volume of data may take considerable time to stop.



# 2. Uninstalling the Printer Driver and Software

## Uninstalling the PCL 6/5e Printer Driver

This section describes how to uninstall the printer driver. The actual procedure may differ depending on the operating system.

Follow one of the appropriate procedures below.

---

### Windows 95/98/Me - Uninstalling the PCL 6/5e Printer Driver

---

- 1** Close all applications that are currently running.
- 2** Click **[Start]** on the taskbar, point to **[Settings]**, and then click **[Printers]**.  
The **[Printers]** window appears.
- 3** Click to select the icon of the printer you want to remove.
- 4** On the **[File]** menu, click **[Delete]**.  
A confirmation dialog box appears.
- 5** Click **[Yes]** to uninstall the printer driver.

---

### Windows 2000/Windows XP/Server 2003 - Uninstalling the PCL 6/5e Printer Driver

---

#### **Limitation**

- Uninstalling a printer driver requires Manage Printers permission. Members of the Administrators and Power Users groups have Manage Printers permission by default. When you uninstall a printer driver, log on using an account that has Manage Printers permission.

- 1** Close all applications that are currently running.
- 2** Click **[Start]** on the taskbar, point to **[Settings]**, and then click **[Printers]**.  
The **[Printers]** window appears.

#### **Note**

- With Windows XP Professional/Windows Server 2003, access the **[Printers and Faxes]** window from **[Start]** on the taskbar.
- With Windows XP Home Edition, open **[Control panel]** from **[Start]**, click **[Printers and Other Hardware]**, and then click **[Printers and Faxes]** on the screen that appears.

**3** Click to select the icon of the printer you want to remove.

**4** On the [File] menu, click [Delete].

A confirmation dialog box appears.

**5** Click [Yes] to uninstall the printer driver.

 **Note**

- Before upgrading the printer driver, restart your computer after uninstalling the old version of the printer driver.

---

## Windows NT 4.0 - Uninstalling the PCL 6/5e Printer Driver

---

 **Limitation**

- Uninstalling a printer driver requires Full Control access permission. Members of the Administrators, Server Operators, Print Operators, and Power Users groups have Full Control Permission by default. When you install a printer driver, log on using an account that has Full Control permission.

**1** Close all applications that are currently running.

**2** Click [Start] on the taskbar, point to [Settings], and then click [Printers].

The [Printers] window appears.

**3** Click to select the icon of the printer you want to remove.

**4** On the [File] menu, click [Delete].

A confirmation dialog box appears.

**5** Click [Yes] to uninstall the printer driver.

 **Note**

- Before upgrading the printer driver, restart your computer after uninstalling the old version of the printer driver.

# Uninstalling the RPCS Printer Driver

This section describes how to uninstall the printer driver. The actual procedure may differ depending on the operating system.

Follow one of the appropriate procedures below.

---

## Windows 95/98/Me - Uninstalling the RPCS Printer Driver

---

2

- 1** Close all applications that are currently running.
- 2** Click **[Start]** on the taskbar, point to **[Settings]**, and then click **[Printers]**.  
The **[Printers]** window appears.
- 3** Click to select the icon of the printer you want to remove.
- 4** On the **[File]** menu, click **[Delete]**.  
A confirmation dialog box appears.
- 5** Click **[Yes]** to uninstall the printer driver.

---

## Windows 2000/Windows XP/Server 2003 - Uninstalling the RPCS Printer Driver

---

### Limitation

- Uninstalling a printer driver requires Manage Printers permission. Members of the Administrators and Power Users groups have Manage Printers permission by default. When you uninstall a printer driver, log on using an account that has Manage Printers permission.

- 1** Close all applications that are currently running.
- 2** Click **[Start]** on the taskbar, point to **[Settings]**, and then click **[Printers]**.  
The **[Printers]** window appears.

### Note

- With Windows XP Professional/Windows Server 2003, access the **[Printers and Faxes]** window from **[Start]** on the taskbar.
  - With Windows XP Home Edition, open **[Control panel]** from **[Start]**, click **[Printers and Other Hardware]**, and then click **[Printers and Faxes]** on the screen that appears.
- 3** Click to select the icon of the printer you want to remove.
  - 4** On the **[File]** menu, click **[Delete]**.  
A confirmation dialog box appears.

**5** Click **[Yes]** to uninstall the printer driver.

 **Note**

- Before upgrading the printer driver, restart your computer after uninstalling the old version of the printer driver.

---

## Windows NT 4.0 - Uninstalling the RPCS Printer Driver

---

 **Limitation**

- Uninstalling a printer driver requires Full Control access permission. Members of the Administrators, Server Operators, Print Operators, and Power Users groups have Full Control Permission by default. When you install a printer driver, log on using an account that has Full Control permission.

**1** Close all applications that are currently running.

**2** Click **[Start]** on the taskbar, point to **[Settings]**, and then click **[Printers]**.

The **[Printers]** window appears.

**3** Click to select the icon of the printer you want to remove.

**4** On the **[File]** menu, click **[Delete]**.

A confirmation dialog box appears.

**5** Click **[Yes]** to uninstall the printer driver.

 **Note**

- Before upgrading the printer driver, restart your computer after uninstalling the old version of the printer driver.



# Uninstalling the PostScript Printer Driver

This section describes how to uninstall the PostScript printer driver. The actual procedure may differ depending on the operating system. Follow one of the appropriate procedures below.

---

## Windows 95/98/Me - Uninstalling the PostScript Printer Driver

---

2

- 1** Close all applications that are currently running.
- 2** Click **[Start]** on the taskbar, point to **[Settings]**, and then click **[Printers]**.  
The **[Printers]** window appears.
- 3** Click to select the icon of the printer you want to remove.
- 4** On the **[File]** menu, click **[Delete]**.  
A confirmation dialog box appears.
- 5** Click **[Yes]** to uninstall the printer driver.

---

## Windows 2000/Windows XP/Server 2003 - Uninstalling the PostScript Printer Driver

---

### Limitation

- Uninstalling a printer driver requires Manage Printers permission. Members of the Administrators and Power Users groups have Manage Printers permission by default. When you uninstall a printer driver, log on using an account that has Manage Printers permission.

- 1** Close all applications that are currently running.
- 2** Click **[Start]** on the taskbar, point to **[Settings]**, and then click **[Printers]**.  
The **[Printers]** window appears.

### Note

- With Windows XP Professional/Windows Server 2003, access the **[Printers and Faxes]** window from **[Start]** on the taskbar.
  - With Windows XP Home Edition, open **[Control panel]** from **[Start]**, click **[Printers and Other Hardware]**, and then click **[Printers and Faxes]** on the screen that appears.
- 3** Click to select the icon of the printer you want to remove.
  - 4** On the **[File]** menu, click **[Delete]**.  
A confirmation dialog box appears.

**5** Click **[Yes]** to uninstall the printer driver.

 **Note**

- Before upgrading the printer driver, restart your computer after uninstalling the old version of the printer driver.

---

## Windows NT 4.0 - Uninstalling the PostScript Printer Driver

---

 **Limitation**

- Uninstalling a printer driver requires Full Control access permission. Members of the Administrators, Server Operators, Print Operators, and Power Users groups have Full Control Permission by default. When you uninstall a printer driver, log on using an account that has Full Control permission.

**1** Close all applications that are currently running.

**2** Click **[Start]** on the taskbar, point to **[Settings]**, and then click **[Printers]**.

The **[Printers]** window appears.

**3** Click to select the icon of the printer you want to remove.

**4** On the **[File]** menu, click **[Delete]**.

A confirmation dialog box appears.

**5** Click **[Yes]** to uninstall the printer driver.

 **Note**

- Before upgrading the printer driver, restart your computer after uninstalling the old version of the printer driver.

---

## Macintosh - Uninstalling the PostScript Printer Driver

---

**1** Drag the "AdobePS" file from the **[Extensions]** folder in **[System Folder]** to **[Trash]**.

**2** Drag the PPD file and plug-in file from the **[Printer Descriptions]** folder in the **[Extensions]** folder in **[System Folder]** to **[Trash]**.

# 3. Paper and Other Media

## Paper and Other Media Supported by This Printer

---

### Paper Types and Sizes

---



This section describes the type, size, feed direction, and maximum amount of paper that can be loaded into each paper tray in this printer.

#### Important

- ❑ If you use damp or curled paper, a misfeed might occur. In this case, try turning over the paper stack in the paper tray. If there is no improvement, change to paper with less curl.

#### Note

- ❑ The following symbols and terminology are used to represent the feed direction.

| In this manual   | On the panel display   | Paper feed direction      |
|--|--|---------------------------|
|  ↑ (Feed direction)  | A4 (210 × 297)<br>Letter (8 <sup>1</sup> / <sub>2</sub> × 11)  | Short-edge feed direction |
|  ↑ (Feed direction) | A4 (297 × 210)<br>Letter (11 × 8 <sup>1</sup> / <sub>2</sub> ) | Long-edge feed direction  |

- ❑ It is recommended that you load paper of the size and direction you frequently use in the tray selected with “Tray Priority”. For more information about Tray Priority, see p.126 “Paper Input Menu”.
- ❑ When loading paper of the same size in more than one tray, it is recommended that you load paper in the same direction in each tray.

#### Reference

For more information about loading each type of paper, see p.49 “Loading Paper and Other Media”.

#### Important



- ❑ Be sure to set the paper size dial to match the actual paper size loaded in the tray. When the actual paper size is not shown on the dial, set the dial to “✖” and select the paper size using the control panel.
- ❑ For Tray 1, 2 and 3, the dial setting overrides the setting made with the control panel.
- ❑ The optional Envelope Feeder Unit requires installation of the optional Paper Feed Unit. Up to two Paper Feed Units can be installed at the same time. The Envelope Feeder Unit can be used in Tray 2 or Tray 3.

**Note**

- ❑ The printable paper size depends on the memory size of the printer and print data, see p.190 “Memory Capacity and Paper Size”.
- ❑ For more information about the meanings of the abbreviations, see the notes at the bottom of each table.

**◆ Input Paper Sizes (Metric version)**

|  | Feed direction | Size (mm)     | Bypass Tray | Paper Tray (Tray1) | Paper Feed Unit (Tray 2/3) | Envelope Feeder Unit |
|--|----------------|---------------|-------------|--------------------|----------------------------|----------------------|
| A3   | ↙              | 297 × 420     | ○           | ☆                  | ☆                          | X                    |
| B4 JIS   | ↙              | 257 × 364     | ○           | ★                  | ★                          | X                    |
| A4   | ↙              | 210 × 297     | ○           | ☆                  | ☆                          | X                    |
|  | ↘              | 297 × 210     | ○           | ☆                  | ☆                          | X                    |
| B5 JIS   | ↙              | 182 × 257     | ○           | ★                  | ★                          | X                    |
|  | ↘              | 257 × 182     | ○           | ★                  | ★                          | X                    |
| A5   | ↙              | 148 × 210     | ○           | X                  | X                          | X                    |
|  | ↘              | 210 × 148     | ○           | ☆                  | X                          | X                    |
| A6   | ↙              | 105 × 148     | ○           | X                  | X                          | X                    |
| 11 × 17  | ↙              | 279 × 432     | ○           | ★                  | ☆                          | X                    |
| Legal (LG, 8 <sup>1</sup> / <sub>2</sub> × 14)                                     | ↙              | 216 × 356     | ○           | ★                  | ☆                          | X                    |
| Letter (LT, 8 <sup>1</sup> / <sub>2</sub> × 11)                                    | ↙              | 216 × 279     | ○           | ☆                  | ☆                          | X                    |
|  | ↘              | 279 × 216     | ○           | ☆                  | ☆                          | X                    |
| 5 <sup>1</sup> / <sub>2</sub> × 8 <sup>1</sup> / <sub>2</sub>                      | ↙              | 140 × 216     | ○           | X                  | X                          | X                    |
| Executive (Exec., 7 <sup>1</sup> / <sub>4</sub> × 10 <sup>1</sup> / <sub>2</sub> ) | ↙              | 184 × 276     | ○           | X                  | ★                          | X                    |
|  | ↘              | 276 × 184     | ○           | ★                  | ★                          | X                    |
| Folio (8 <sup>1</sup> / <sub>4</sub> × 13)   | ↙              | 210 × 330     | ○           | ★                  | ★                          | X                    |
| Foolscap (F4, 8 <sup>1</sup> / <sub>2</sub> × 13)                                  | ↙              | 216 × 330     | ○           | ★                  | ★                          | X                    |
| F/GL (8 × 13)  | ↙              | 203 × 330     | ○           | ★                  | ★                          | X                    |
| Com#10 Env (4 <sup>1</sup> / <sub>8</sub> × 9 <sup>1</sup> / <sub>2</sub> )        | ↙              | 104.8 × 241.3 | ○           | X                  | X                          | ○                    |
| C5 Env (6.38 × 9.02)   | ↙              | 162 × 229     | ○           | X                  | X                          | ○                    |
| C6 Env (4.49 × 6.38)   | ↙              | 114 × 162     | ○           | X                  | X                          | ○                    |
| DL Env (4.33 × 8.66)   | ↙              | 110 × 220     | ○           | X                  | X                          | ○                    |
| Monarch Env (3 <sup>7</sup> / <sub>8</sub> × 7 <sup>1</sup> / <sub>2</sub> )       | ↙              | 98.4 × 190.5  | ○           | X                  | X                          | ○                    |
| Custom Size  | —              | —             | ○*          | X                  | ★**                        | X                    |

|                              | Feed direction  | Size (mm) | Bypass Tray | Paper Tray (Tray1) | Paper Feed Unit (Tray 2/3) | Envelope Feeder Unit |
|------------------------------|---|-----------|-------------|--------------------|----------------------------|----------------------|
| 8K ( $10^1/2 \times 15.35$ ) |  | 267 × 390 | ○           | ★                  | ★                          | X                    |
| 16K ( $7.68 \times 10^1/2$ ) |  | 195 × 267 | ○           | ★                  | ★                          | X                    |
|                              |  | 267 × 195 | ○           | ★                  | ★                          | X                    |

- ○  
Means that the size is supported but the paper size should be set with the control panel. There is no dial on the tray.  
See p.52 “Loading Paper in the Bypass Tray”  
See p.60 “Loading envelopes into the Envelope Feeder Unit”
- ☆  
Means that the size is supported and indicated on the tray dial. Be sure to set the paper size dial to match the actual paper size loaded in the tray.
- ★  
Means that the size is supported but not indicated on the tray dial. You should set the tray dial to “✱”, and select the paper size with the control panel.
- ○\*  
Means that the supported size is approximately 90 - 305 mm in width, and approximately 148 - 432 mm in length. The supported size may differ depending on the printer language you use. Use the printer driver to set custom sizes. Set custom sizes with the control panel.
- ★\*\*  
Means that the supported size is approximately 182 - 297 mm in width, and approximately 160 - 432 mm in length. The supported size may differ depending on the printer language you use. Use the printer driver to set custom sizes. Set custom sizes with the control panel.
- X  
Means that the size is not supported.

### ◆ Input Paper Sizes (Inch version)

|   | Feed direction | Size (inch)  | Bypass Tray | Paper Tray (Tray1) | Paper Feed Unit (Tray 2/3) | Envelope Feeder Unit |
|---|----------------|--|-------------|--------------------|----------------------------|----------------------|
| 11 × 17   | ☞              | 11 × 17  | ○           | ☆                  | ☆                          | X                    |
| Legal (LG)  | ☞              | 8 <sup>1</sup> / <sub>2</sub> × 14                             | ○           | ☆                  | ☆                          | X                    |
| Letter (LT)   | ☞              | 8 <sup>1</sup> / <sub>2</sub> × 11                             | ○           | ☆                  | ☆                          | X                    |
|   | ☞              | 11 × 8 <sup>1</sup> / <sub>2</sub>                             | ○           | ☆                  | ☆                          | X                    |
| 5 <sup>1</sup> / <sub>2</sub> × 8 <sup>1</sup> / <sub>2</sub> | ☞              | 5 <sup>1</sup> / <sub>2</sub> × 8 <sup>1</sup> / <sub>2</sub>  | ○           | X                  | X                          | X                    |
| Executive (Exec.)   | ☞              | 7 <sup>1</sup> / <sub>4</sub> × 10 <sup>1</sup> / <sub>2</sub> | ○           | X                  | ★                          | X                    |
|   | ☞              | 10 <sup>1</sup> / <sub>2</sub> × 7 <sup>1</sup> / <sub>4</sub> | ○           | ★                  | ★                          | X                    |
| A3  | ☞              | 11.26 × 16.54  | ○           | ★                  | ☆                          | X                    |
| B4 JIS  | ☞              | 10.12 × 14.33  | ○           | ★                  | ★                          | X                    |
| A4  | ☞              | 8.26 × 5.83  | ○           | ★                  | ☆                          | X                    |
|   | ☞              | 5.83 × 8.26  | ○           | ☆                  | ☆                          | X                    |
| B5 JIS  | ☞              | 7.17 × 10.12   | ○           | ★                  | ★                          | X                    |
|   | ☞              | 10.12 × 7.17   | ○           | ★                  | ★                          | X                    |
| A5  | ☞              | 5.83 × 8.26  | ○           | X                  | X                          | X                    |
|   | ☞              | 8.26 × 5.83  | ○           | ★                  | X                          | X                    |
| A6  | ☞              | 4.13 × 5.63  | ○           | X                  | X                          | X                    |
| Folio   | ☞              | 8 <sup>1</sup> / <sub>4</sub> × 13                             | ○           | ★                  | ★                          | X                    |
| Foolscap F4   | ☞              | 8 <sup>1</sup> / <sub>2</sub> × 13                             | ○           | ☆                  | ★                          | X                    |
| F/GL  | ☞              | 8 × 13   | ○           | ★                  | ★                          | X                    |
| Com10 Env   | ☞              | 4 <sup>1</sup> / <sub>8</sub> × 9 <sup>1</sup> / <sub>2</sub>  | ○           | X                  | X                          | ○                    |
| C5 Env  | ☞              | 6.38 × 9.02  | ○           | X                  | X                          | ○                    |
| C6 Env  | ☞              | 4.49 × 6.38  | ○           | X                  | X                          | ○                    |
| DL Env  | ☞              | 4.33 × 8.66  | ○           | X                  | X                          | ○                    |
| Monarch Env   | ☞              | 3 <sup>7</sup> / <sub>8</sub> × 7 <sup>1</sup> / <sub>2</sub>  | ○           | X                  | X                          | ○                    |
| Custom Size   | —              | —  | ○*          | X                  | ★**                        | X                    |
| 8K  | ☞              | 10 <sup>1</sup> / <sub>2</sub> × 15.35                         | ○           | ★                  | ★                          | X                    |
| 16K   | ☞              | 7.68 × 10 <sup>1</sup> / <sub>2</sub>                          | ○           | ★                  | ★                          | X                    |
|   | ☞              | 10 <sup>1</sup> / <sub>2</sub> × 7.68                          | ○           | ★                  | ★                          | X                    |

- ○  
Means that the size is supported but the paper size should be set with the control panel. There is no dial on the tray.  
See p.52 “Loading Paper in the Bypass Tray”  
See p.60 “Loading envelopes into the Envelope Feeder Unit”
- ☆  
Means that the size is supported and indicated on the tray dial. Be sure to set the paper size dial to match the actual paper size loaded in the tray.
- ★  
Means that the size is supported but not indicated on the tray dial. You should set the tray dial to “✱”, and select the paper size with the control panel.
- ○\*  
Means that the supported size is approximately 3.54 - 12.01 inches in width, and approximately 5.83 - 17.01 inches in length. The supported size may differ depending on the printer language you use. Use the printer driver to set custom sizes. Set custom sizes with the control panel.
- ★\*\*  
Means that the supported size is approximately 7.17 - 11.69 inches in width, and approximately 6.30 - 17.01 inches in length. The supported size may differ depending on the printer language you use. Use the printer driver to set custom sizes. Set custom sizes with the control panel.
- X  
means that the size is not supported.

#### ◆ Paper weight and number of sheets to be set

|                                   | Supported paper weight                          | Maximum number of sheets (plain paper)  |
|-----------------------------------|---|---|
| Paper Tray                        | 60 - 105 g/m <sup>2</sup><br>(16 - 28 lb. bond) | 500 (80 g/m <sup>2</sup> , 20 lb. bond)   |
| Paper Feed Unit Type 600 (option) | 60 - 105 g/m <sup>2</sup><br>(16 - 28 lb. bond) | 500 (80 g/m <sup>2</sup> , 20 lb. bond)   |
| Bypass Tray                       | 52 - 162 g/m <sup>2</sup><br>(14 - 43 lb. bond) | 100 (80 g/m <sup>2</sup> , 20 lb. bond)<br>For other kind of papers, see p.45 “Types of Paper and Other Media”. |
| Envelope Feeder Type 2600         | p.45 “Types of Paper and Other Media”.          |   |

\*1 Confirm that the top of the stack is not higher than the limit mark indicated on the side fence of the tray.

\*2 The Envelope Feeder Unit requires the installation of the optional Paper Feed Unit.

### ◆ Output Paper Sizes (Metric version)





|  | Feed direction | Size (mm)     | Output Tray<br>(Standard Tray) | 1-bin Shift<br>Sort Tray | Mailbox | Duplex Unit |
|--|----------------|---------------|--------------------------------|--------------------------|---------|-------------|
| A3   | ☐              | 297 × 420     | ○                              | ○                        | ○       | ○           |
| B4 JIS   | ☐              | 257 × 364     | ○                              | ○                        | ○       | ○           |
| A4   | ☐              | 210 × 297     | ○                              | ○                        | ○       | ○           |
|  | ☐              | 297 × 210     | ○                              | ○                        | ○       | ○           |
| B5 JIS   | ☐              | 182 × 257     | ○                              | ○                        | ○       | ○           |
|  | ☐              | 257 × 182     | ○                              | ○                        | ○       | ○           |
| A5   | ☐              | 148 × 210     | ○                              | X                        | X       | X           |
|  | ☐              | 210 × 148     | ○                              | ○                        | ○       | ○           |
| A6   | ☐              | 105 × 148     | ○                              | X                        | X       | X           |
| 11 × 17  | ☐              | 279 × 432     | ○                              | ○                        | ○       | ○           |
| Legal (LG, 8 <sup>1</sup> / <sub>2</sub> × 14)                                     | ☐              | 216 × 356     | ○                              | ○                        | ○       | ○           |
| Letter (LT, 8 <sup>1</sup> / <sub>2</sub> × 11)                                    | ☐              | 216 × 279     | ○                              | ○                        | ○       | ○           |
|  | ☐              | 279 × 216     | ○                              | ○                        | ○       | ○           |
| 5 <sup>1</sup> / <sub>2</sub> × 8 <sup>1</sup> / <sub>2</sub>                      | ☐              | 140 × 216     | ○                              | X                        | X       | X           |
| Executive (Exec., 7 <sup>1</sup> / <sub>4</sub> × 10 <sup>1</sup> / <sub>2</sub> ) | ☐              | 184 × 276     | ○                              | ○                        | ○       | X           |
|  | ☐              | 276 × 184     | ○                              | ○                        | ○       | ○           |
| Folio (8 <sup>1</sup> / <sub>4</sub> × 13)   | ☐              | 210 × 330     | ○                              | ○                        | ○       | ○           |
| Foolscap (F4, 8 <sup>1</sup> / <sub>2</sub> × 13)                                  | ☐              | 216 × 330     | ○                              | ○                        | ○       | ○           |
| F/GL (8 × 13)  | ☐              | 203 × 330     | ○                              | ○                        | ○       | ○           |
| Com#10 Env (4 <sup>1</sup> / <sub>8</sub> × 9 <sup>1</sup> / <sub>2</sub> )        | ☐              | 104.8 × 241.3 | ○                              | X                        | X       | X           |
| C5 Env (6.38 × 9.02)   | ☐              | 162 × 229     | ○                              | X                        | X       | X           |
| C6 Env (4.49 × 6.38)   | ☐              | 114 × 162     | ○                              | X                        | X       | X           |
| DL Env (4.33 × 8.66)   | ☐              | 110 × 220     | ○                              | X                        | X       | X           |
| Monarch Env (3 <sup>7</sup> / <sub>8</sub> × 7 <sup>1</sup> / <sub>2</sub> )       | ☐              | 98.4 × 190.5  | ○                              | X                        | X       | X           |
| Custom Size  | —              | —             | ○                              | ○*                       | ○*      | X           |
| 8K (10 <sup>1</sup> / <sub>2</sub> × 15.35)  | ☐              | 267 × 390     | ○                              | ○                        | ○       | ○           |
| 16K (7.68 × 10 <sup>1</sup> / <sub>2</sub> )                                       | ☐              | 195 × 267     | ○                              | ○                        | ○       | ○           |
|  | ☐              | 267 × 195     | ○                              | ○                        | ○       | ○           |



- ○  
Means that the size is supported.
- ○\*  
Means that the supported size is approximately 182 - 297 mm in width, and approximately 148 - 432 mm in length.
- X  
Means that the size is not supported.

#### ◆ Output Paper Sizes (Inch version)

|   | Feed direction | Size (inch)  | Output Tray (Standard Tray) | 1-bin Shift Sort Tray | Mailbox | Duplex Unit |
|---|----------------|--|-----------------------------|-----------------------|---------|-------------|
| 11 × 17   | ☞              | 11 × 17  | ○                           | ○                     | ○       | ○           |
| Legal (LG)  | ☞              | 8 <sup>1</sup> / <sub>2</sub> × 14                             | ○                           | ○                     | ○       | ○           |
| Letter (LT)   | ☞              | 8 <sup>1</sup> / <sub>2</sub> × 11                             | ○                           | ○                     | ○       | ○           |
|   | ☞              | 11 × 8 <sup>1</sup> / <sub>2</sub>                             | ○                           | ○                     | ○       | ○           |
| 5 <sup>1</sup> / <sub>2</sub> × 8 <sup>1</sup> / <sub>2</sub> | ☞              | 5 <sup>1</sup> / <sub>2</sub> × 8 <sup>1</sup> / <sub>2</sub>  | ○                           | X                     | X       | X           |
| Executive (Exec.)   | ☞              | 7 <sup>1</sup> / <sub>4</sub> × 10 <sup>1</sup> / <sub>2</sub> | ○                           | ○                     | ○       | X           |
|   | ☞              | 10 <sup>1</sup> / <sub>2</sub> × 7 <sup>1</sup> / <sub>4</sub> | ○                           | ○                     | ○       | ○           |
| A3  | ☞              | 11.26 × 16.54  | ○                           | ○                     | ○       | ○           |
| B4 JIS  | ☞              | 10.12 × 14.33  | ○                           | ○                     | ○       | ○           |
| A4  | ☞              | 8.26 × 5.83  | ○                           | ○                     | ○       | ○           |
|   | ☞              | 5.83 × 8.26  | ○                           | ○                     | ○       | ○           |
| B5 JIS  | ☞              | 7.17 × 10.12   | ○                           | ○                     | ○       | ○           |
|   | ☞              | 10.12" × 7.17  | ○                           | ○                     | ○       | ○           |
| A5  | ☞              | 5.83 × 8.26  | ○                           | X                     | X       | X           |
|   | ☞              | 8.26 × 5.83  | ○                           | ○                     | ○       | ○           |
| A6  | ☞              | 4.13 × 5.63  | ○                           | X                     | X       | X           |
| Folio   | ☞              | 8 <sup>1</sup> / <sub>4</sub> × 13                             | ○                           | ○                     | ○       | ○           |
| Foolscap F4   | ☞              | 8 <sup>1</sup> / <sub>2</sub> × 13                             | ○                           | ○                     | ○       | ○           |
| F/GL  | ☞              | 8 × 13   | ○                           | ○                     | ○       | ○           |
| Com#10 Env  | ☞              | 4 <sup>1</sup> / <sub>8</sub> × 9 <sup>1</sup> / <sub>2</sub>  | ○                           | X                     | X       | X           |
| C6 Env  | ☞              | 4.49 × 6.38  | ○                           | X                     | X       | X           |
| C5 Env  | ☞              | 6.38 × 9.02  | ○                           | X                     | X       | X           |
| DL Env  | ☞              | 4.33 × 8.66  | ○                           | X                     | X       | X           |

|             | Feed direction  | Size (inch)   | Output Tray (Standard Tray) | 1-bin Shift Sort Tray | Mailbox | Duplex Unit |
|-------------|---|---|-----------------------------|-----------------------|---------|-------------|
| Monarch Env |  | 3 <sup>7</sup> / <sub>8</sub> × 7 <sup>1</sup> / <sub>2</sub> | ○                           | X                     | X       | X           |
| Custom Size | —   | —   | ○                           | X                     | X       | X           |
| 8K          |  | 10 <sup>1</sup> / <sub>2</sub> × 15.35                        | ○                           | ○                     | ○       | ○           |
| 16K         |  | 7.68 × 10 <sup>1</sup> / <sub>2</sub>                         | ○                           | ○                     | ○       | ○           |
|             |  | 10 <sup>1</sup> / <sub>2</sub> × 7.68                         | ○                           | ○                     | ○       | ○           |

- Means that the size is supported and that the paper size should be set with the control panel. There is no dial on the tray.
- \* Means that the supported size is approximately 7.18 - 11.68 inches in width, and approximately 5.83 - 17.00 inches in length.
- X Means that the size is not supported.

---

## Paper Recommendations

---

Note the following suggestions when handling or selecting paper used with this printer.

---

### Loading Paper

---

- Confirm the paper types of the printer. For more information, see p.45 “Types of Paper and Other Media”. Print quality cannot be guaranteed if other paper types are used.
- Do not use paper that is already printed on.
- If you load paper into the paper tray, be sure not to stack over the limit mark.
- If you load paper onto the Bypass Tray, be sure that paper fits under the side guide.
- If you load paper into the paper tray, confirm that the print side is facing *down*.
- If you load paper onto the Bypass Tray, confirm that the print side is facing *up*.

---

## Storing Paper

---

Paper should always be stored properly. Improperly stored paper might result in poor print quality, paper misfeeds or printer damage.

Recommendations are as follows:

- Avoid storing paper in humid areas.
- Avoid exposing paper to direct sunlight.
- Store on a flat surface.
- Keep open reams of paper in the package in which the paper came.

---

## Types of Paper and Other Media

---

### ❖ Plain paper

- If you print on paper heavier than 105 g/m<sup>2</sup> (28 lb. bond), use the Bypass Tray. The Bypass Tray can hold paper up to 162 g/m<sup>2</sup> (43 lb. bond) in weight.
- If you load paper heavier than 155 g/m<sup>2</sup> (41 lb. bond) onto the Bypass Tray, set the printer to Thick Paper mode using the control panel.
- If paper is curled or bent, correct it before loading.

### ❖ OHP transparencies

- Load only one OHP transparency at the same time onto the Bypass Tray.
- When loading an OHP transparency onto the Bypass Tray, set the printer to Transparency mode with the control panel.
- Be careful not to touch the print side of the OHP transparencies, otherwise the print side gets dirty or damaged, and results in poor print quality.
- When printing on an OHP transparency that has a print side, load it facing down onto the Bypass Tray.

### ❖ Adhesive labels

- Load only one adhesive label at the same time onto the Bypass Tray.
- Use adhesive labels in which the whole side can be printed on.
- Do not use adhesive labels having exposed glue.
- If the print side is coated, print quality might be reduced, as the toner might not fuse well.

❖ **Envelopes**

- When printing on envelopes, use the Bypass Tray or the Envelope Feeder Unit.
- Even when the optional Envelope Feeder Unit is not installed, you can select the sizes for the Envelopes for Tray 2 using the control panel. However, you cannot load the envelopes until optional Envelop Feeder Unit is installed.

To use the Envelope Feeder Unit, installation of the optional Paper Feed Unit is required. See “Envelope Feeder Type 2600” in the Setup Guide.

- Specifications of envelopes are as follows:

|                             | Metric version                                 | Inch version   |
|-----------------------------|--|--|
| Weight                      | 72 – 90 g/m <sup>2</sup>                       | 19 – 24 lb. bond   |
| Recommended weight and size | 72 g/m <sup>2</sup> , 114 × 162 mm<br>(C6 Env) | 24 lb. bond, 3 <sup>7</sup> / <sub>8</sub> × 7 <sup>1</sup> / <sub>2</sub> inches<br>(Monarch) |

- You can load up to 10 envelopes (72 – 90 g/m<sup>2</sup>, 19 – 24 lb. bond) onto the Bypass Tray at the same time, without forcibly pressing them. Confirm that the envelopes are not damp, and that the top of the stack is not higher than the limit mark on the side guide. See p.58 “Loading envelopes onto the Bypass Tray”.
- You can load up to 60 envelopes (72 – 90 g/m<sup>2</sup>, 19 – 24 lb. bond) into optional Envelope Feeder Unit at the same time, without forcibly pressing them. Confirm that the envelopes are not damp, and that the top of the stack is not higher than the limit mark on the side guide. See p.60 “Loading envelopes into the Envelope Feeder Unit”.
- Confirm that the print side is facing up when loading onto the Bypass Tray, and facing down when loading into the optional Envelope Feeder Unit.
- Load the envelopes with the flaps aligned to the left side fence. The flaps should be securely folded up.
- Confirm that there is no air in the envelopes before loading.
- To get better print quality, it is recommended that you set the right, left, top, and bottom print margin, to at least 15 mm (0.6 inches) each.
- Do not print on both sides of envelopes.
- Load only one size and type of envelopes at the same time.
- Before loading envelopes, flatten the leading edges (the side being fed into the printer) of them by running a pencil or ruler across them.
- Before loading envelopes, confirm that they are rectangular in shape.
- Do not use the non-supported envelopes listed on p.41 “Paper weight and number of sheets to be set”.

---

**Paper not supported by this printer**

---

Avoid using the following types of paper that are not supported by this printer:

- Paper whose weight is heavier or lighter than the limitation. See p.37 “Paper Types and Sizes”.
- Bent, folded or creased paper
- Curled or twisted paper
- Torn paper
- Wrinkled paper
- Damp paper
- Paper stuck together
- Paper that is dry enough to emit static electricity
- Paper that has already been printed on, with the exception of preprinted letterhead

 **Note**

- Ink on paper from an earlier print job, another copier, an inkjet printer or other device could damage the fusing unit of this printer due to a difference in fusing temperatures.
- Coated paper
- Special paper like thermal paper, aluminum foil, carbon paper and conductive paper
- Heavily textured paper
- Glued paper
- Label paper on which glue or base paper is exposed
- Paper with clips or stapled
- Paper with tape or ribbons attached
- Envelopes in the following conditions:
  - damp
  - excessively curled or twisted
  - stuck together
  - damaged in any way
  - with stamps attached
  - with windows, holes, perforations, cutouts or embossing
  - with metal clasps, string ties or metal folding bars
  - designed to be interlocked
  - with nicked edges or bent corners
  - with rough, wrinkled or laid finishes
  - with any exposed adhesive, when the flap is in the sealed or closed position

## Printable Area

The following shows the printable area for this printer. Be sure to set the print margins correctly by the application.

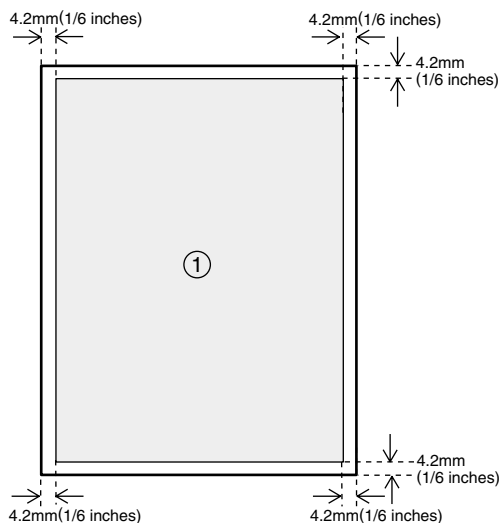

① : printable area

### Important

- The maximum printable length is 432 mm (17 inches) in the paper feed direction.

### Note

- Although the entire surface of the paper can be printed on, depending on the printer driver and settings, print quality is reduced if all margins are set to 5 mm.
- When loading oversized paper into the Bypass Tray, support it by hand so it feeds in properly. Also, since the paper feeding and the paper printed may differ, depending on thickness and width, check print results in advance.

# Loading Paper and Other Media

## Loading Paper in the Paper Tray

Load paper in the optional Paper Feed Unit by following the procedures below.

### Reference

Up to 500 sheets of paper can be loaded in the paper tray. Up to 500 sheets of paper can be loaded in the Paper Feed Unit. This means a maximum of 1,600 sheets can be simultaneously loaded when two additional Paper Feed Units are installed. For more information about type, size and feed direction of paper that can be loaded in the tray, see p.37 "Paper Types and Sizes".

When you change the paper size see p.50 "Changing the paper size".

- 1** Lift the paper tray slightly then pull it out until it stops.

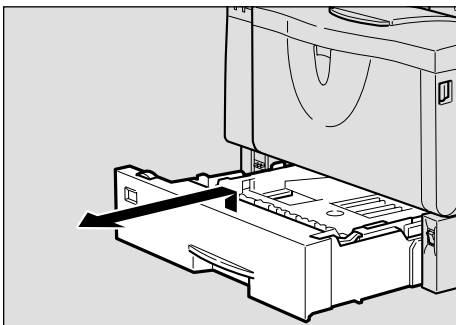

ZKGY430E

- 2** While lifting the front side of the tray, pull it out of the printer.

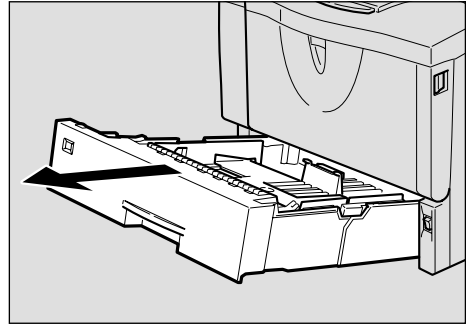

ZKGY140E

- 3** Load paper into the tray with the print side down.

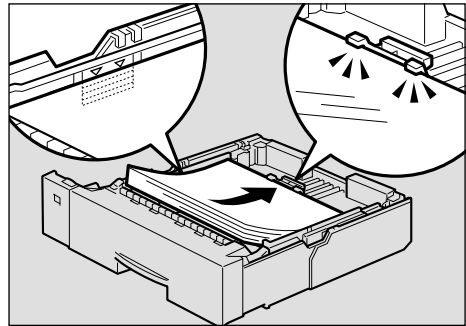

ZKGY130E

### Important

- Confirm that the top of the stack is not higher than the limit mark inside the tray.
- Confirm that paper fits under the rear guide.

- 4** Lift the front of the tray, and slide it carefully into the printer until it stops.

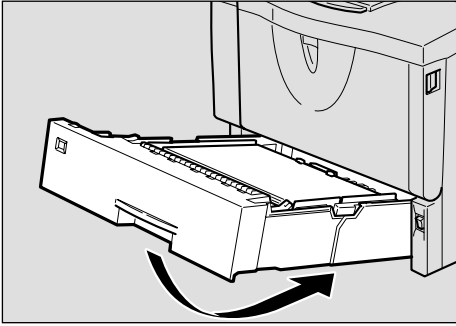

ZKGY150E

**Important**

- Do not slide the paper tray in with force. If you do, the front and side guides might move.

**Changing the paper size**

**Important**

- Confirm that the setting of the paper size dial matches the paper size and feed direction of the paper in the tray, otherwise the printer might be damaged, or printing problems might occur.

The following explanation uses the example of "Tray 1" for the paper tray.

- 1** Lift the paper tray slightly then pull it out until it stops. Adjust the paper size dial to match the size and feed direction of paper in the paper tray.

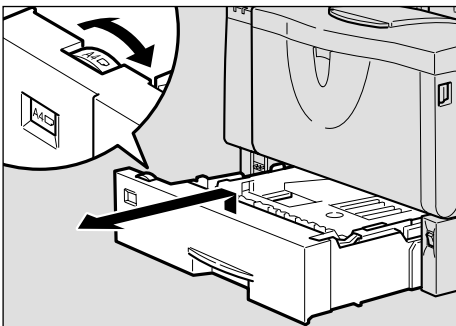

ZKGY110E

**Important**

- If you want to use the paper size and feed direction that are not indicated on the paper size dial, set the dial to "✳". In this case, you should set the paper size using the control panel. See p.126 "Paper Input Menu".

- 2** While lifting the front side of the tray, pull it out of the printer.

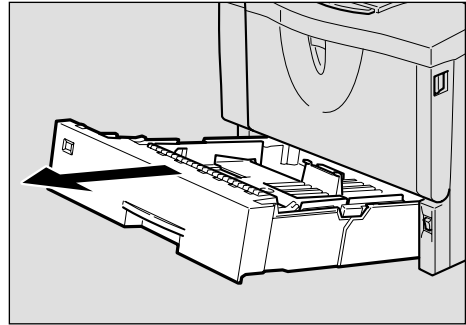

ZKGY140E

- 3** If you load paper larger than A4 or 8 1/2 x 11, you should extend the tray as follows:

**Note**

- You cannot load paper smaller than A4 or 8 1/2 x 11, if the tray is extended. In this case, return the tray to its standard length.

- 1** Slide the catches inwards to unlock the tray.

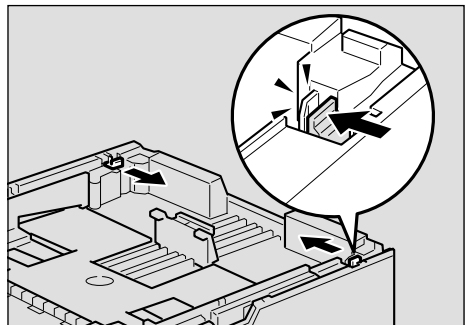

ZKGY160E

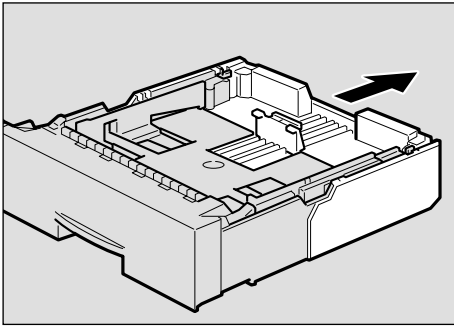

**2** Slide the tray until it stops.

ZKGY170E

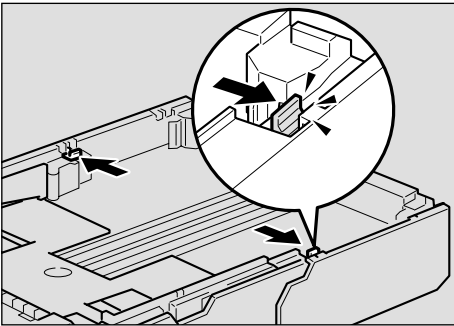
**3** Return the catches to their original positions.

ZKGY180E

**Important**

- Confirm that the catches return to their original positions securely. If they are not locked securely, paper mis-feeds might occur.

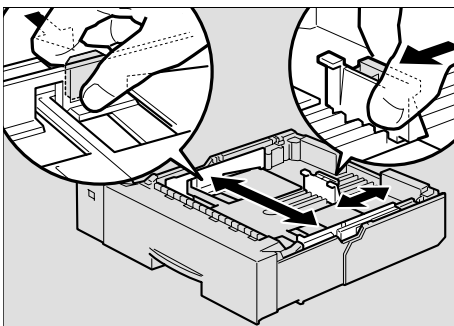
**4** Adjust the rear and side guides to the paper size you want to load.

ZKGY120E

**Important**

- To avoid damage, pinch the paper guides when moving them.

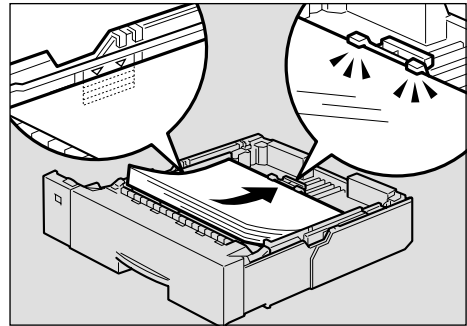
**5** Load paper into the tray with the print side down.

ZKGY130E

**Important**

- Confirm that the top of the stack is not higher than the limit mark inside the tray.
- Confirm that paper fits under the rear guide.

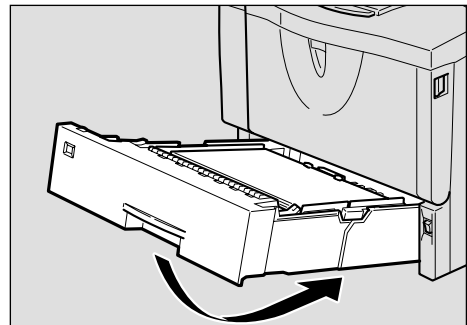
**6** While lifting the front side of the tray, place into the printer. Then carefully slide it into the printer until it stops.

ZKGY150E

**Important**

- Do not slide the paper tray in with force. If you do, the front and side guides might move.

**7** Attach the paper tray cover provided when you have pulled out the tray extension, as in step **3**.

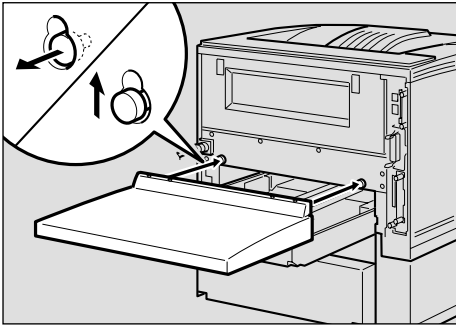

**3**

**Note**

- The paper tray cover contains four mounting holes.
  - Use the two outer holes when attaching the paper tray cover as a cover for the standard tray.
  - Use the two inner holes when attaching the paper tray cover as a cover for an additional tray.

---

## Loading Paper in the Bypass Tray

---

---

### Opening and Closing the Bypass Tray

---

Open the Bypass Tray

---

**1** Open the Bypass Tray.

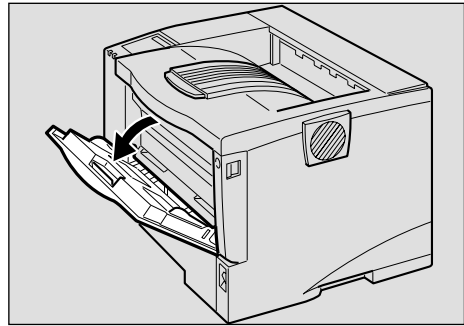

Close the Bypass Tray

---

When you have finished using the Bypass Tray, close it as shown in the next step.

**1** Close by pressing the button in the center of the Bypass Tray.

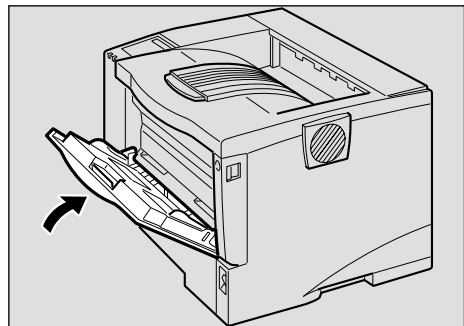

## Loading Paper in the Bypass Tray

### Reference

With the Bypass Tray, you can load up to 100 pages at the same time. For more information about the type, size and feed direction of paper that can be loaded in the tray, see p.37 “Paper Types and Sizes”.

### Note

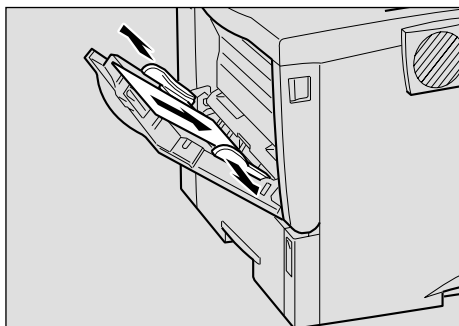

- If you set custom size paper, you should set the paper size using the printer driver. Also, use the control panel to set the custom size setting.

- 1** Slide the side guides outward, and load paper until it stops with the print side up.



ZKGY200E

### Note

- If you load A4  or larger, or 8<sup>1</sup>/<sub>2</sub> × 11  or larger, slide out the Bypass Tray extension (1) and then flip it open (2).

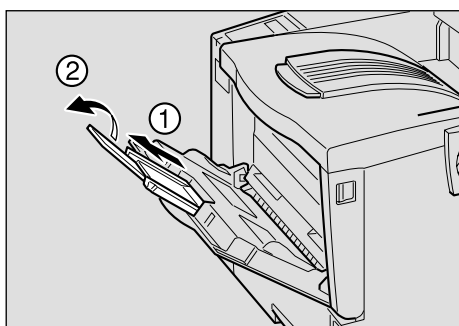

ZKGY210E

- 2** Adjust the side guides to the paper width.

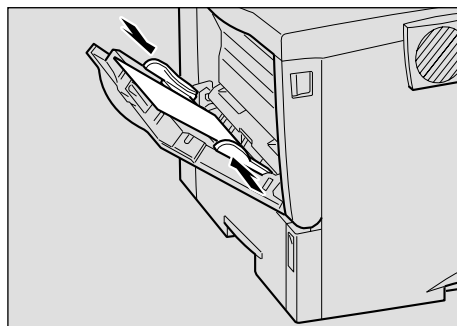

ZKGY220E

### Important

- Confirm that paper fits under the side guides.

- 3** Set the paper size and feed direction using the control panel as follows:

- 1** Press **[Menu]**.

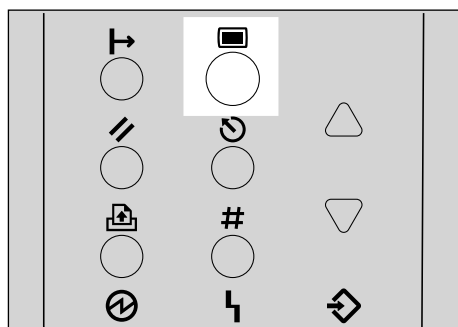

ZKGS020E

“Menu” appears on the panel display.

- 2** Press **[▼]** or **[▲]** to “Paper Input” menu.

Menu  
Paper Input

**3** Press **[Enter #]**.

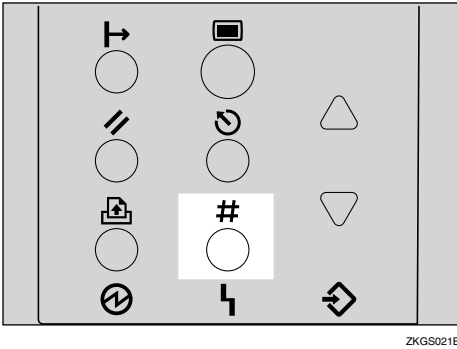

The following message appears on the panel display.

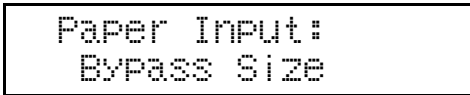

**4** Press **[Enter #]**.

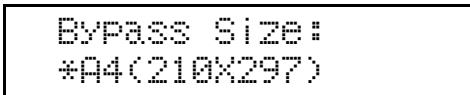

**5** Press **[▼]** or **[▲]** to select the paper size you want to use.

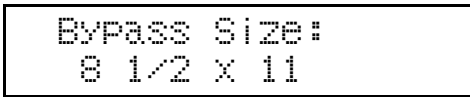

**6** Press **[Enter #]** to apply the setting. Wait for a while.

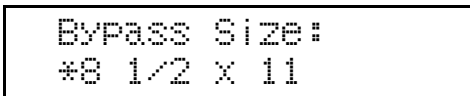

The screen returns to step **3** in a few seconds.

**7** After the panel display changes, press **[On Line]**.

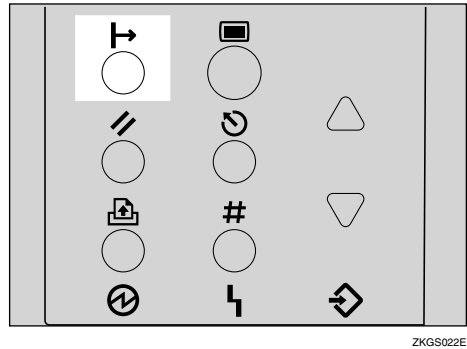

"Ready" appears on the panel display.



**4** Start printing with the computer.

**Loading custom sized paper in the Bypass Tray**

**Important**

- The settings of custom sized paper that take effect are not the settings made on the control panel but the settings made in the printer driver. There is no need to change the settings on the control panel. However, when using a printer driver other than RPCS, you will need to change the settings on the control panel.
- Applications that do not allow a custom paper size to be set cannot print on custom sized paper.

**Note**

- If you print on A3 or longer sheets, prints may become blurred.

- 1** Press **[Menu]**.

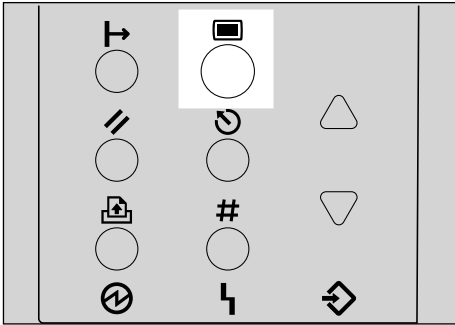

ZKGS020E

"Menu" appears on the panel display.

- 2** Press **[▼]** or **[▲]** to display "Paper Input" menu.

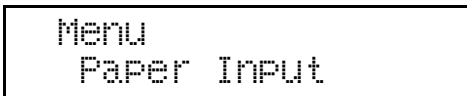

- 3** Press **[Enter #]**.

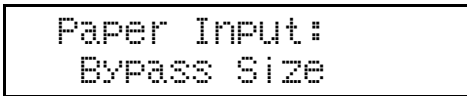

The following message appears on the panel display.

- 4** Press **[▼]** or **[▲]** to display "Custom Size".

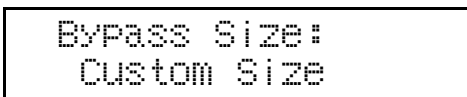

- 5** Press **[Enter #]**.

The following message appears on the panel display.

- 6** Press **[▼]** or **[▲]** to display the length in the feed direction, and then press **[Enter #]**.

**Note**

- Pressing **[▼]** or **[▲]** scrolls the value in increments of 1 mm. Pressing **[▼]** or **[▲]** scrolls the value in increments of 10 mm.

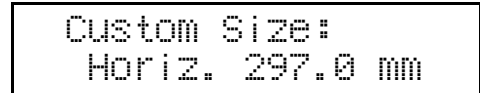

The screen to enter the size along the length appears.

- 7** Press **[▼]** or **[▲]** to display the size along the length of the feed direction, and then press **[Enter #]**.

**Note**

- Pressing **[▼]** or **[▲]** scrolls the value in increments of 1 mm. Pressing **[▼]** or **[▲]** scrolls the value in increments of 10 mm.

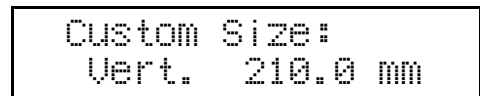

The screen returns to step **4** in a few seconds.

- 8** Press **[On Line]**.

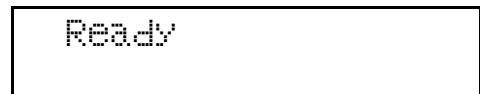

"Ready" appears on the panel display.

### Setting the Bypass Tray Paper Type

To make sure printing is done correctly, you must specify one of the following for the type of sheets loaded in the tray:

- Plain paper, Recycled paper, Special paper, Color paper, Letterhead, Preprinted, Labels, Transparencies, Thick paper

#### Important

- ❑ When you load thick paper or transparencies in the Bypass Tray, always specify the type of paper. Duplex printing is not possible on paper in a tray for which Thick paper or Transparency has been set.

**1** Press **[Menu]**.

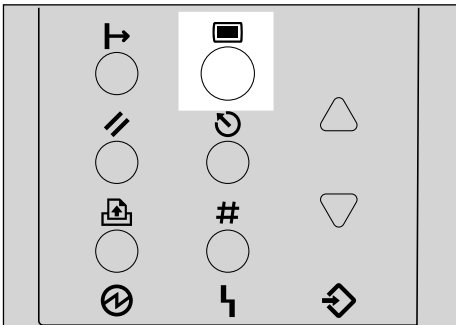

ZKGS020E

"Menu" appears on the panel display.

**2** Press **[▼]** or **[▲]** to display "Paper Input" menu.

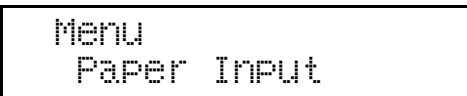

**3** Press **[Enter #]**.

The following message appears on the panel display.

**4** Press **[▼]** or **[▲]** to display "Paper Type".

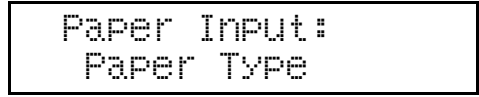

**5** Press **[Enter #]**.

The following message appears on the panel display.

**6** Press **[▼]** or **[▲]** to display "Bypass Tray", and then press **[Enter #]**.



The screen to select the paper type appears.

**7** Press **[▼]** or **[▲]** to display the type of paper you have loaded, and then press **[Enter #]**.

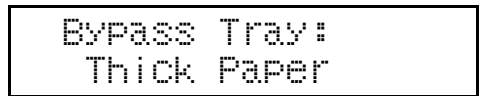

The screen returns to step **6** in a few seconds.

**8** Press **[On Line]**.



"Ready" appears on the panel display.

## Loading Paper in the Optional Paper Tray

### Reference

With the Paper Feed Unit, you can load up to 500 pages at the same time.

For more information about the type, size and feed direction of paper that can be loaded in the tray, see p.37 “Paper Types and Sizes”.

### Important

- ❑ If the printer is equipped with the optional tray(s), do not slide out more than one tray at the same time. If you do, the printer might fall down.
- ❑ Confirm that the setting of the paper size dial matches the paper size and feed direction of the paper in the tray. If different, the printer might be damaged, or printing problems might occur.

- 1** Lift the paper tray slightly then pull it out until it stops. Adjust the paper size dial to match the size and feed direction of paper in the Paper Feed Unit.

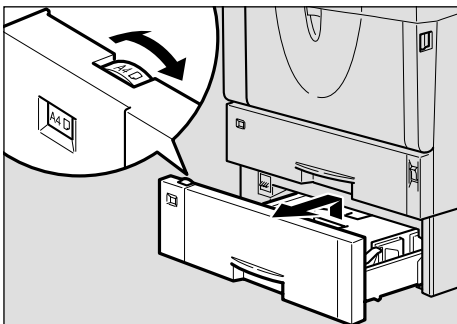

ZKGY230E

### Important

- ❑ If you want to use paper sizes or feed directions that are not listed on the paper size dial, adjust the dial to “✖”. In this case, you should set the paper size using the control panel. See p.126 “Paper Input Menu”.

- 2** While lifting the front side of the tray, pull it out of the printer.

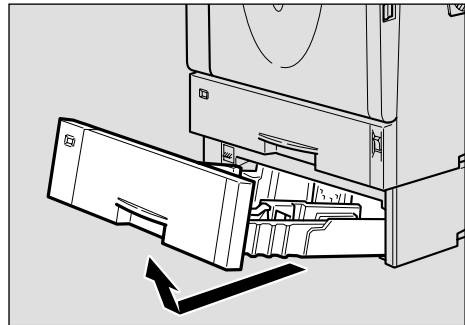

ZKGP330E

- 3** Adjust the rear and side guides to the paper size you want to load.

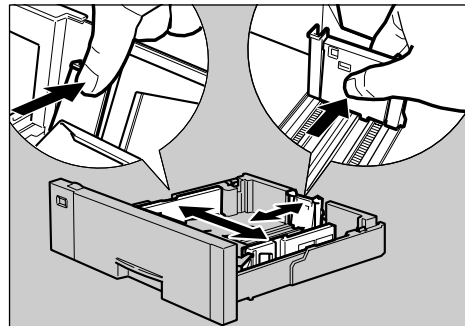

ZKGY250E

- 4** Load paper into the paper tray with the print side down.

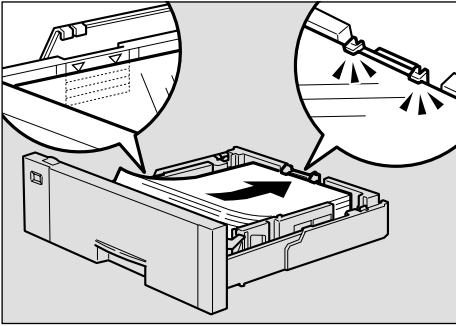

ZKGY261E

**Important**

- Confirm that the top of the stack is not higher than the limit mark inside the tray.
- Confirm that paper fits under the rear guide.

- 5** Lift the front of the tray, and slide it carefully into the printer until it stops.

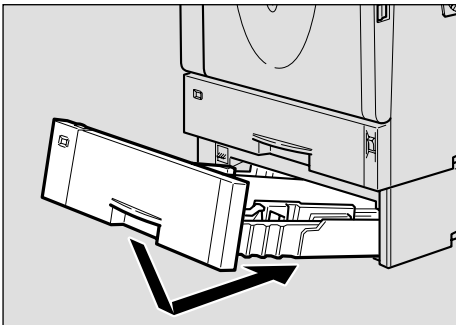

ZKGP340E

**Important**

- Do not slide the paper tray in with force. If you do, the front and side guides might move.

---

## Loading Envelopes

---

As there are many kinds of envelopes, be sure to check if those to be used are supported by this printer.

**Reference**

For more information about envelopes, see p.45 “Types of Paper and Other Media”.

**Important**

- Even if the optional Envelope Feeder is not installed, you can select envelope sizes for Tray 2 and Tray 3 using the control panel. However, you cannot load envelopes until the optional Envelope Feeder Unit is installed.
- To install the Envelope Feeder Unit, the optional Paper Feed Unit must be installed. See “Envelope Feeder Type 2600” in the Setup Guide.

---

## Loading envelopes onto the Bypass Tray

---

**Reference**

With the Bypass Tray, you can load up to 10 envelopes at the same time. For more information about envelopes, see p.45 “Types of Paper and Other Media”.

To open and close the Bypass Tray, see p.52 “Opening and Closing the Bypass Tray”



- 1 Load envelopes until they stop, with the print side up and the sides of the flaps on the left as shown below.

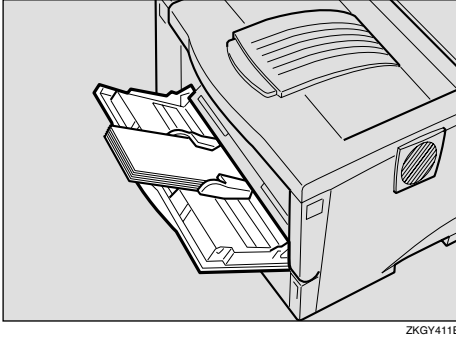

### Important

- ❑ Confirm that the envelope flaps are securely folded down, and that there is no air inside the envelopes.

### Note

- ❑ Confirm that the top of the stack is not higher than the limit mark on the side guides.
- ❑ Do not push the stack of envelopes with too much force.

- 2 Slide the side guides against the edge of the envelope stack.

### Note

- ❑ Confirm that the edges of envelopes fit under the side guides.

- 3 Set the envelope size and feed direction using the control panel as follows:

- 1 Press **[Menu]**.

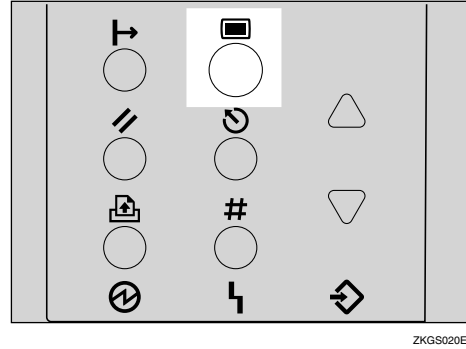

“Menu” appears on the panel display.

- 2 Press **[▲]** or **[▼]** to display “Paper Input” menu.



- 3 Press **[Enter #]**.

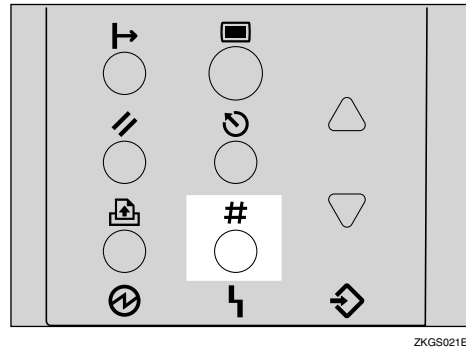

The following message appears.

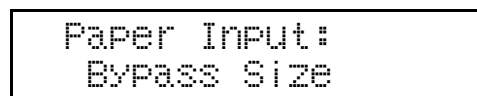

- 4 Press **[Enter #]**.

- 5 Press **[▲]** or **[▼]** to select the envelope type you want to use.

**Reference**

For information about types of envelopes you can select, see p.37 "Paper and Other Media Supported by This Printer".

- 6 Press **[Enter #]** to apply the settings. Wait for a while.

- 7 After the panel display changes, press **[On Line]**.

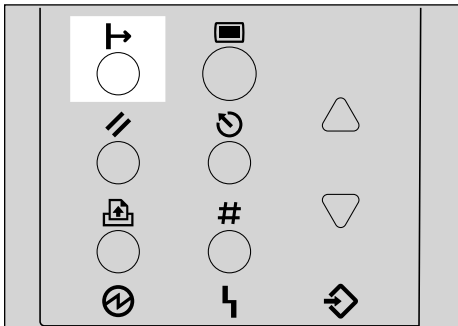

ZKGS022E

"Ready" appears on the panel display.



- 4 Start printing with the computer.

**Loading envelopes into the Envelope Feeder Unit**

**Important**

- With the optional Envelope Feeder Unit, you can load up to 60 envelopes at the same time. For more information about envelopes, see p.45 "Types of Paper and Other Media".

The following explanation uses the example of installing the Envelope Feeder Unit in "Tray 2".

- 1 Slide the optional Paper Feed Unit (Tray 2) out until it stops. Next, lift it slightly, then slide it out.

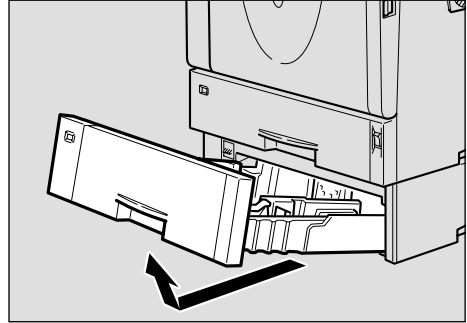

ZKGP330E

**Note**

- Keep the paper tray with paper in a cool and dry place.

- 2 Prepare the Envelope Feeder Unit.

- 3 While pinching the side guides, slide them outward until they stop. While pinching the rear guide, slide it toward the back.

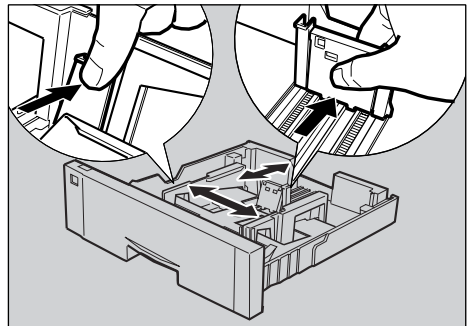

ZKGY260E

- 4** Push the bottom plate down until it locks into place.

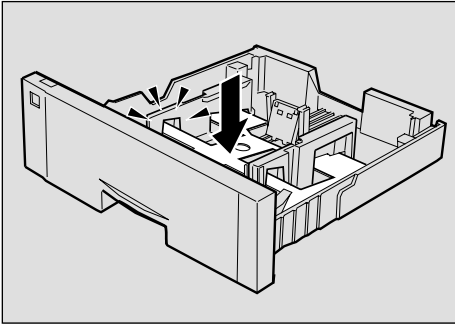

ZKGP380E

- 5** Load envelopes into the Envelope Feeder Unit, with the print side down and the flap on the left as shown in the illustration.

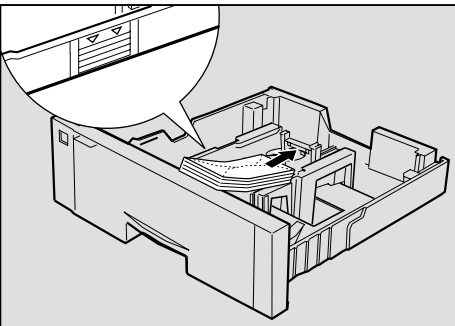

ZKGP380E

### Important

- Confirm that the envelope flaps are securely folded down, and that there is no air inside the envelopes.

### Note

- Confirm that the top of the stack is not higher than the limit mark on the side guides.
- Confirm that the envelopes fit under the side guides.
- Do not push the stack of envelopes with too much force.

- 6** While pinching the side guides, slide them along the edge of the envelope stack.

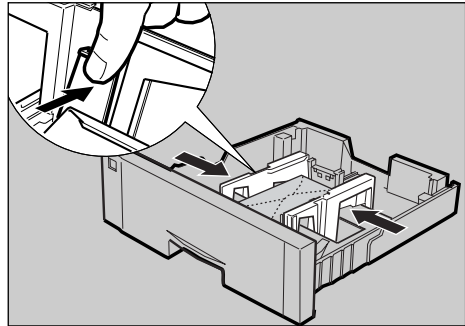

ZKGY370E

- 7** While pinching the rear guide, slide it along the edge of the envelope stack.

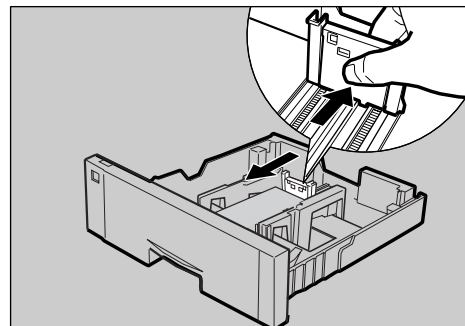

ZKGY390E

- 8** Lift the front of the tray, and slide it carefully into the printer until it stops.

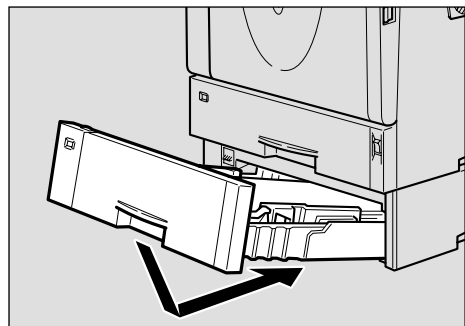

ZKGP340E

### Important

- Do not slide the paper tray in with force. If you do, the front and side guides might move.

**9** Set the envelope size and feed direction using the control panel as follows:

**1** Press **[Menu]**.

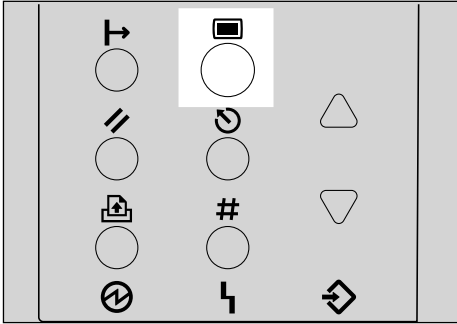

ZKGS020E

"Menu" appears on the panel display.

**2** Press **[▲]** or **[▼]** to display "Paper Input" menu.



**3** Press **[Enter #]**.

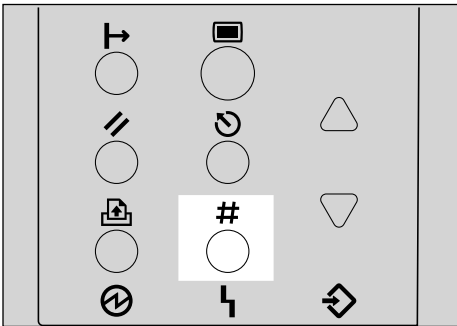

ZKGS021E

The following message appears on the panel display.

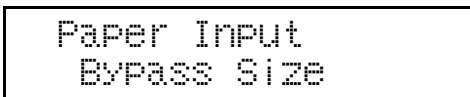

**4** Press **[▲]** or **[▼]** to display "Tray Paper Size".



**5** Press **[Enter #]**.

The following message appears on the panel display.



**6** Press **[▲]** or **[▼]** to display "Tray 2".



**7** Press **[Enter #]**.

**8** Press **[▲]** or **[▼]** to select the envelope type you want to use.

**Reference**

For more information about types of envelopes you can select, see p.37 "Paper and Other Media Supported by This Printer".

**9** Press **[Enter #]**. Wait for a while.

**10** After the panel display changes, press **[On Line]**.

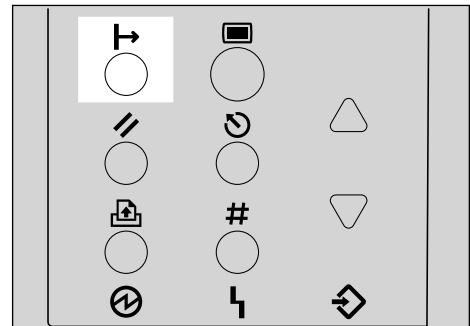

ZKGS022E

"Ready" message appears on the control panel.



**10** Start printing with the computer.

# 4. Sample Print/Locked Print

## Sample Print

Use this function to print only the first set of a multiple-set print jobs. The remaining sets are saved on the optional Hard Disk Drive in the printer. The saved job can be printed or canceled from the printer's control panel.

Also, files specified for Sample Print can be printed or deleted using the Web browser. For details, see *Network Printing Guide*.

### Important

- Turning the printer off deletes any documents or error logs stored on the optional hard disk drive.
- The files printed or deleted using the Web browser are not listed in the Sample Print files displayed from the control panel.
- If Sample Print is executed from the Web browser when the list of Sample Print files is displayed from the control panel, although they appear on the control panel, they cannot be printed or deleted from it.

### Limitation

- To use this function, the optional Hard Disk Drive must be installed on the printer.

### Reference

For more information about settings for printer driver, see the printer driver Help.

### Note

- If the application has a collate option, confirm that it is not selected before sending a print job. By default, sample print jobs are automatically collated by the printer driver. If the collate option is selected from the application print dialog box, more pages than intended may be printed.
- You can identify the file you want to print by the User ID and the time when the job was stored.
- The actual number of pages the printer can save depends on the contents of the print images. For example, the printer can save up to 30 jobs or 1,000 pages. It depends on the data volume.
- If the first set of the sample print file is not as you expected and you do not want to print the remaining sets, delete the sample print file using the control panel. If you print the remaining sets of the sample print file, the job in the printer is deleted automatically.

## Printing a Sample Print File

The following procedure describes how to print a sample print file with the PCL printer driver. For information about how to print a sample print file with the PostScript printer driver, see the PostScript 3 Operating Instructions Supplement included on the CD-ROM. For more information about RPCS printer driver, see Help.

- 1** From an application, select the menu command to print.

The print dialog box appears.

- 2** Open the Printer Properties.

- 3** From the [Job Type:] box on the [Setup] tab, select [Sample Print].

- 4** Click the [Details...] button.

- 5** In the [User ID:] box, type a User ID of up to eight alphanumeric characters.

 **Note**

- This is used to identify the user associated with a job.
- The User ID can consist of up to eight alphanumeric (a-z, A-Z, 0-9) characters.

- 6** Click [OK].

- 7** After making all desired settings, click [OK].

- 8** Start printing from the application's print dialog box.

The sample print job is sent to the printer and the first set is printed.

- 9** Check the print job to confirm whether the settings are acceptable.

If the settings are fine, go to step 10 to print the rest of the print job.

If not, you can delete the saved job. See p.66 "Deleting a Sample Print File"

 **Limitation**

- Documents are not stored on the optional hard disk drive in the following cases (any documents not stored can be confirmed in the error log):

- A Sample Print or Locked Print document is the 31st document sent when a total of 30 documents have already been stored on the optional hard disk drive.
- The last sent document causes the total number of document pages stored on the optional hard disk drive to exceed 1,000.

- 10** On the printer's control panel, press [Menu].

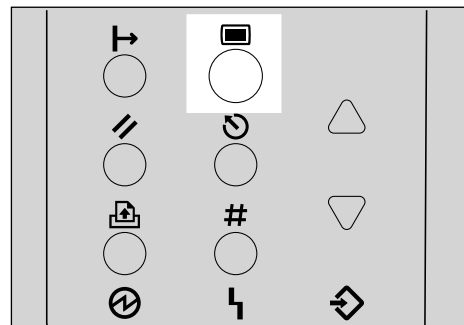

ZKGS020E

"Menu" appears on the panel display.

- 11 Press [▼] or [▲] to display the “Sample Print” menu.

```
Menu:
  Sample Print
```

- 12 Press [Enter #].

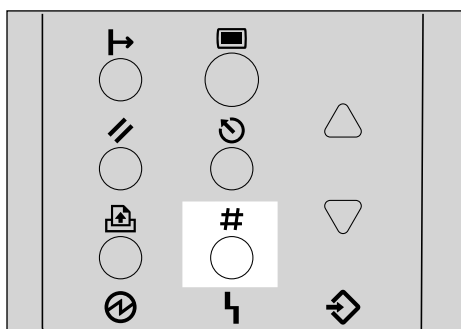

ZKGS021E

The following message appears on the panel display.

```
Sample Print:
  08:56 ABCD1234
```

- 13 Press [▼] or [▲] to display the file you want to print, and then press [Enter #].

```
Select Action:
  Print File
```

**Note**

- If you want to cancel the sample print file, press [Escape].

- 14 Press [Enter #].

The following message appears on the panel display.

```
Qty: 1(1-999)
  Press # to Print
```

- 15 Press [▲] or [▼] to enter the number of sets.

**Note**

- You can enter up to 999 sets.

```
Qty: 6(1-999)
  Press # to Print
```

- 16 Press [Enter #] to print the file.

The following message appears on the panel display.

```
Processing...
```

**Note**

- If you are not satisfied with the first printout of the sample print file and do not want to print the remainder, the job in the printer is deleted automatically.

## Deleting a Sample Print File

If you are not satisfied with the print-out, delete the sample print file. Then revise it and print again until the settings are fine.

**1** Press [Menu].

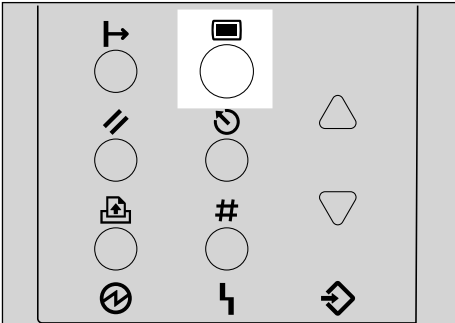

ZKGS020E

"Menu" appears on the panel display.

**2** Press [▼] or [▲] to display the "Sample Print" menu .



**3** Press [Enter #].

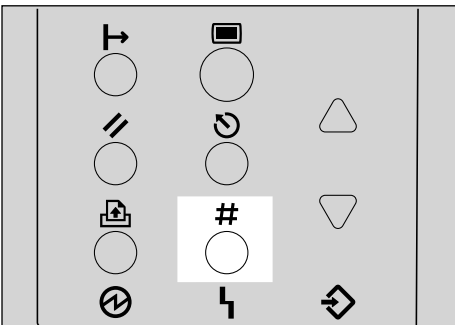

ZKGS021E

The following message appears on the panel display.

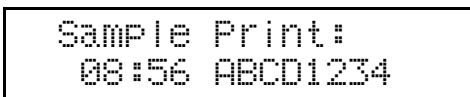

**4** Press [▼] or [▲] to display the file you want to delete, and then press [Enter #].

The following message appears on the panel display.



**Note**

- If you want to cancel the deletion of a sample print file, press [Escape].

**5** Press [▼] or [▲] to display "Delete File", and then press [Enter #].

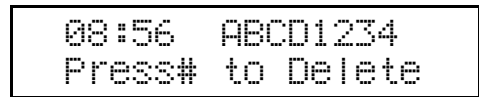

**6** Press [Enter #] to delete the file.

The following message appears on the panel display.



**7** Press [On Line].

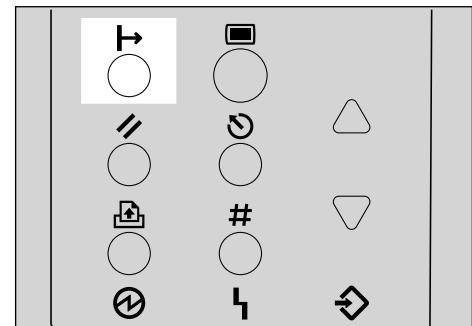

ZKGS022E

"Ready" appears on the panel display.





## Checking the Error Log

### ! Limitation

- ❑ Up to 70 error logs can be stored for sample print or locked print. Among these 70 error logs, 20 error logs each are stored as respective error logs. The remaining 30 error logs are either sample print or locked print error logs. Thus, if there are 20 belonging to one error log, the maximum number of other error logs is 50.

### 1 Press [Menu].

"Menu" appears on the panel display.

### 2 Press [▼] or [▲] to display the "Sample Print" menu.

```
Menu:
  Sample Print
```

### 3 Press [Enter #].

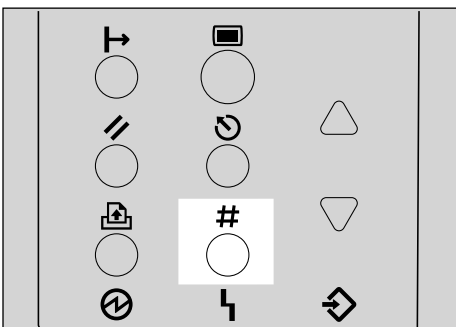

ZKGS021E

The following message appears on the panel display.

```
Sample Print:
  08:56 ABCD1234
```

### 4 Press [▼] or [▲] to display "Error File(s)".

```
Sample Print:
  Error File(s)
```

### 5 Press [Enter #].

The following message appears on the panel display.

```
Error File(s):
  06:52 ABCD1234
```

### ✎ Note

- ❑ You can check the other error logs by using [▼] or [▲].

### 6 Press [▼] or [▲] to check "Error File(s)", and then press [Enter #].

The following message appears on the panel display.

```
Sample Print:
  Error File(s)
```

### 7 Press [On Line].

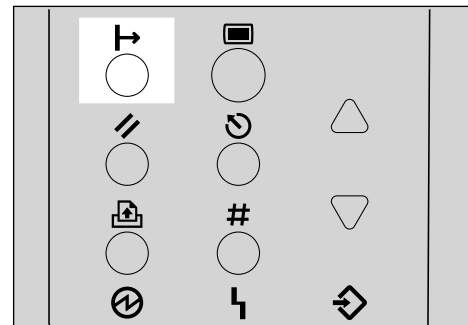

ZKGS022E

"Ready" appears on the panel display.

```
Ready
```

# Locked Print

Use this function to maintain privacy when printing confidential documents. Documents will not be printed out automatically, unless a password is entered, using the control panel after sending the print job.

Also, files specified for Locked Print can be printed or deleted using the Web browser. For details, see *Network Printing Guide*.

4

## Important

- Turning the printer off deletes any documents or error logs stored on the optional hard disk drive.
- The files printed or deleted using the Web browser are not listed in the Locked Print files displayed from the control panel.
- If Locked Print is executed from the Web browser when the list of Locked Print files is displayed from the control panel, although they appear on the control panel, they cannot be printed or deleted from it.

## Limitation

- To use this function, the optional Hard Disk Drive must be installed on the printer.

## Note

- If the application has a collate option, confirm that it is not selected before sending a print job. By default, locked print jobs are automatically collated by the printer driver. If the collate option is selected from the application print dialog box, more pages than intended may be printed.
- You can identify the file you want to print by the User ID and the time when the job was stored.
- The actual number of pages the printer can save depends on the contents of the print images. For example, the printer can save up to 30 jobs or 1,000 pages. It depends on the data volume.
- After the locked print file is printed, the job in the printer is deleted automatically.

## Printing a Locked Print File

The following procedure describes how to print a locked print file with the PCL printer driver. For information about how to print a locked print file with the PostScript printer driver, see the PostScript 3 Operating Instructions Supplement included on the CD-ROM. For more information about RPCS printer driver, see Help.

- 1** From an application, select the menu command to print.

The print dialog box appears.

- 2** Open the Printer Properties.

- 3** From the [Job Type:] box on the [Setup] tab, select [Locked Print].

- 4** Click the [Details:] button.

- 5** In the [User ID:] box, type a User ID of up to eight alphanumeric characters.

### Note

- This is used to identify the user associated with a job.
- The User ID can consist of up to eight alphanumeric (a-z, A-Z, 0-9) characters.

- 6** In the [Password:] box, type a password of four digits.

### Note

- The password must be four digits (0-9).

- 7** Click [OK].

- 8** After making all desired settings, click [OK].

- 9** Start printing from the application's print dialog box.

The locked print job is sent to the printer.

### Limitation

- If Locked Print is executed from the Web Image Monitor while the list of Locked Print files is displayed from the control panel, although they appear on the control panel, they cannot be printed or deleted from it.
  - A Sample Print or Locked Print document is the 31st document sent when a total of 30 documents have already been stored on the optional hard disk drive.
  - The last sent document causes the total number of document pages stored on the optional hard disk drive to exceed 1,000.

- 10** On the printer's control panel, press [Menu].

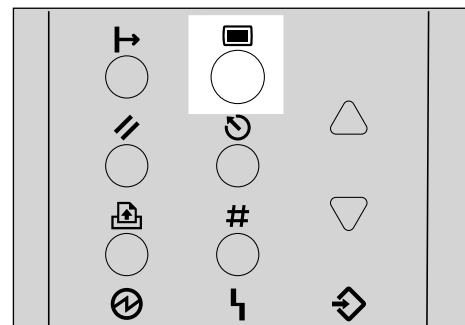

ZKGS020E

"Menu" appears on the panel display.

- 11** Press [▼] or [▲] to display "Locked Print" menu.

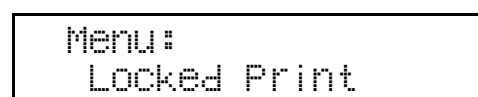

**12** Press **[Enter #]**.

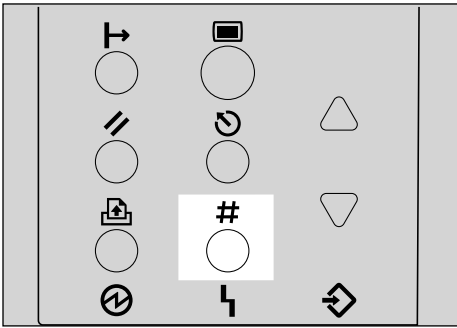

The following message appears on the panel display.



**13** Press **[▼]** or **[▲]** to display a file you want to print, and then press **[Enter #]**.

The following message appears on the panel display.

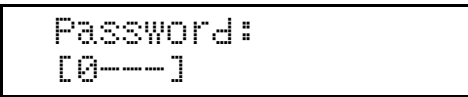

**14** Enter the password you entered in step **6**.

**1** Press **[▲]** or **[▼]** to enter the leftmost digit of the password.

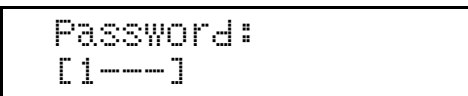

**2** Press **[Enter #]**.

The next digit appears.

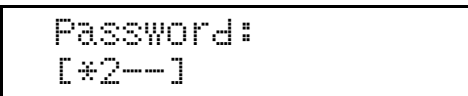

**Note**

- If you want to change the locked print file, press **[Escape]**.

**3** Repeat steps **1** and **2** to enter the remaining digit of the password, and the press **[Enter #]**.

If the password is not correct, the following message appears and the panel display returns to the password menu. Reset or reenter the password.



**15** Press **[▼]** or **[▲]** to display "Print File", and then press **[Enter #]**.



**Note**

- If you want to change the locked print file, press **[Escape]**.

**16** Press **[Enter #]**.

The following message appears on the panel display.



**17** Press **[Enter #]** to print the file.



## Deleting the Locked Print File

- 1 Press **[Menu]**.

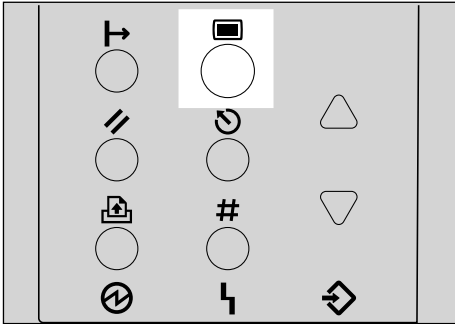

ZKGS020E

"Menu" appears on the panel display.

- 2 Press **[▼]** or **[▲]** to display the "Locked Print" menu.

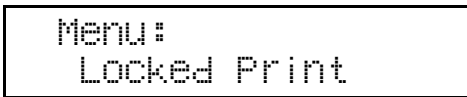

- 3 Press **[Enter #]**.

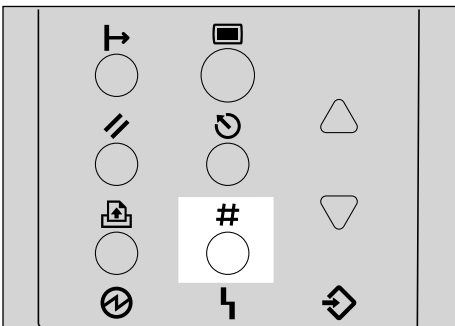

ZKGS021E

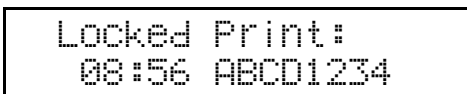

- 4 Press **[▼]** or **[▲]** to display the file you want delete, and then press **[Enter #]**.

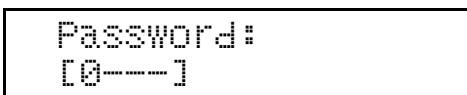

- 5 Enter the password of the locked print file.

- 1 Press **[▲]** or **[▼]** to enter the leftmost digit of the password.

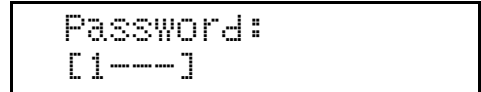

- 2 Press **[Enter #]**.

The next digit appears.

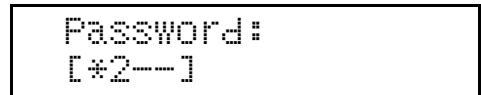

**Note**

- If you want to change the locked print file, press **[Escape]**.

- 3 Repeat steps 1 and 2 to enter the remaining password digits, and then press **[Enter #]**.

If the password is not correct, the following message appears and the panel display returns to the password menu. Reenter the password.

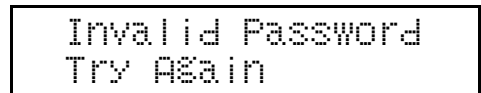

- 6 Press **[▼]** or **[▲]** to display "Delete File".

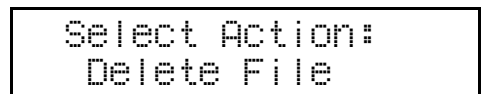

**7** Press **[Enter #]**.

The following message appears on the panel display.



**Note**

- If you want to change the locked print file, press **[Escape]**.

**8** Press **[Enter #]**.

The following message appears on the panel display.



**9** Press **[On Line]**.

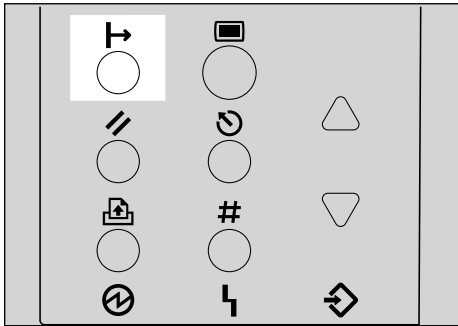

"Ready" appears on the panel display.



## Checking the Error Log

**Limitation**

- Up to 70 error logs can be stored for sample print or locked print. Among these 70 error logs, 20 error logs each are stored as respective error logs. The remaining 30 error logs are either sample print or locked print error logs. Thus, if there are 20 belonging to one error log, the maximum number of other error logs is 50.

**1** Press **[Menu]**.

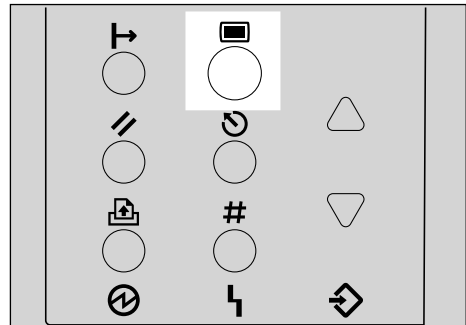

"Menu" appears on the panel display.

**2** Press **[▼]** or **[▲]** to display the "Locked Print" menu.



**3** Press **[Enter #]**.

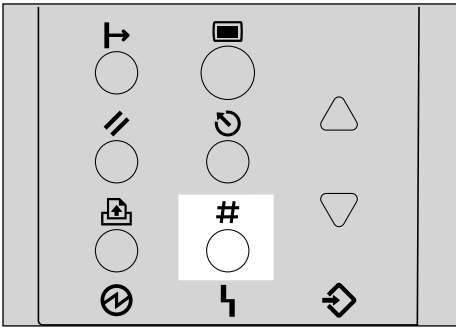

ZKGS021E

The following message appears on the panel display.

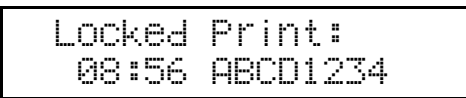

**4** Press **[▼]** or **[▲]** to display "Error File(s)".

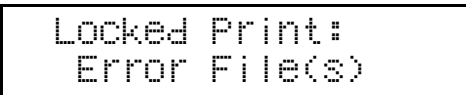

**5** Press **[Enter #]**.

The following message appears on the panel display.



**6** Press **[▼]** or **[▲]** to check "Error File(s)", and then press **[Escape]**.

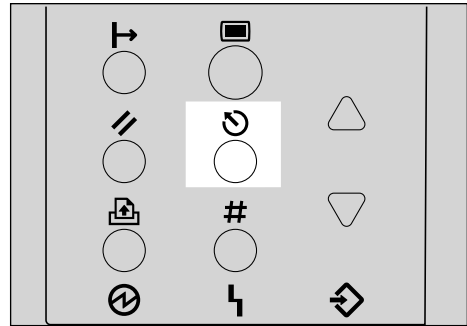

ZKGS024E

The following message appears on the panel display.

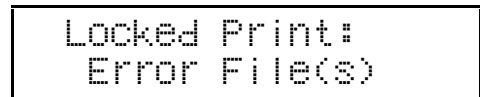

**Note**

Press **[Escape]** to return to the previous menu.

**7** Press **[On Line]**.

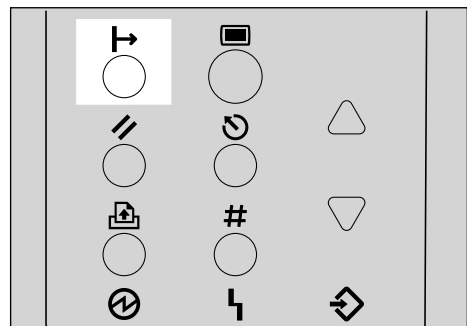

ZKGS022E

"Ready" appears on the panel display.



4







# 5. Troubleshooting

## Error & Status Messages on the Control Panel

| Messages/Second messages  | Description  | Solution  |
|---|--|---|
| Call Service: EC<br>Power Off On<br>/If Error Reoccur<br>Call Service | An error has occurred in the printer.  | First, turn the power switch off and then on. If the message appears again, call your sales or service representative.  |
| Cannot Check<br>Signal in Ad hoc                                      | The signal strength for the wireless LAN cannot be checked because "802.11 Ad hoc" or "Ad hoc" is selected in Comm. Mode for IEEE 802.11b on the Host Interface menu. The signal strength for wireless LAN cannot be checked because "Ad hoc" is selected in "Comm. Mode" for "IEEE 802.11b" in the Host Interface menu. | Signal strength cannot be checked with "802.11b Ad hoc" or "Ad hoc".<br>Change the Transmission mode to <b>[Infrastructure]</b> in the Host Interface settings.   |
| Cannot execute  | When using Sample Print or Locked Print, print/delete cannot be performed via Web browser.   |   |
| Change Setting<br>Tray #<br>/Paper Size:<br>Paper Type:               | The paper type and size setting on the tray differs from the setting on the driver.  | Load { paper size and type } paper with the selected feed direction into tray. Printing will not automatically resume if the paper type, size and direction setting is incorrect. Make sure that the paper size, feed directions and paper type set in the printer driver and on the control panel are the same. There are two methods to resume printing.<br>① Use the control panel to set the correct paper type, size and direction of the paper in tray.<br>② Press <b>[Form Feed]</b> and select the tray with the control panel. |

| Messages/Second messages                                | Description  | Solution   |
|---|--|--|
| Change Setting<br>Tray #<br>/Paper Size:<br>Paper Type: | The paper type and size setting on the tray differs from the setting on the driver   | You can make to setting to print disregarding the error message.<br><br> <b>Reference</b><br>See "Ppr.Size Error" in p.137 "Maintenance Menu Parameters". |
| Close Duplex Unit                                       | The cover of the optional Duplex Unit is open.   | Close the cover of the optional Duplex Unit.   |
| Close Front Cover                                       | The front cover is open.   | Close the front cover.   |
| Close Rear/Paper Exit Cover                             | The paper exit cover or the rear cover is open.  | Close the paper exit cover or the rear cover.  |
| Close Mailbox Cover                                     | The cover of the Mailbox is open.  | Close the cover of the Mailbox.  |
| Close Upper Tray Cover                                  | The cover of the output 1-bin Tray is open.  | Close the cover of the output 1-bin Tray.  |
| Collate Cancelled                                       | The Collate feature has been cancelled.  | Increase the RAM Capacity.   |
| DHCP assigned Cannot change                             | The following address have already been assigned by DHCP: IP Address, Gateway Address, Subnet Mask.                                  | Disable the default DHCP setting in Network in order to enter the addresses manually.  |
| Driver Setting Error (Memory)                           | The printer identified a download error. This error may occur when the installed memory amount is less than the driver setting.      | Verify that the proper memory size is specified via the driver setting.  |
| Duplex Cancelled  | Duplex printing specifications canceled due to insufficient memory or selection of a paper size not compatible with duplex printing. | Install additional memory units or reduce the amount of data sent.   |
| Energy Save Mode  | The printer is in Energy Saver mode.   | Wait for a while.  |
| Enter between 4 & 32 characters                         | When setting the password, the user must enter the correct number of alphanumeric characters.  | Enter the correct number of alphanumeric characters.   |
| Error: Enter 10 or 26 Characters                        | WEP Key setting error, the number of alphanumeric numbers should be either 10 or 26.   | Enter the correct value.   |

| Messages/Second messages      | Description   | Solution  |
|-------------------------------|---|---|
| Exceeded Max. Pages (Collate) | The printer identified a collation table overflow error.                                    | Install additional memory units or reduce the amount of data sent.  |
| Exceeded Max. Stored Pages    | The maximum number of pages has been exceeded during Sample Print or Locked Print.          | Reduce the number of pages to print.  |
| Exceeded Max. Stored Files    | The maximum number of stored files has been exceeded during Sample Print or Locked Print.   | Delete the stored files.  |
| File already deleted          | In Sample Print or Locked Print, the user is attempting to delete an already deleted files. |   |
| File System Full              | The File system is full, so the PDF cannot be printed.                                      | Increase RAM/HDD capacity.  |
| Hardware Problem DIMM         | An error has occurred in the printer.   | First, turn the power switch off and then on. If the message appears again, call your sales or service representative.  |
| Hardware Problem Ethernet     | An error has occurred in the Network Interface Board.                                       | First, turn off the power switch and then on. If the message appears again, call your sales or service representative.  |
| Hardware Problem HDD          | An error has occurred in the optional Hard Disk Drive.                                      | First, turn the power switch off and then on, If the message appears again, call your sales or service representative.  |
|                               |   | Turn off the power switch. Replace the Hard Disk Drive and turn on the power switch. See "Hard Disk Drive Type 2600" in the Setup Guide.  |
|                               |   | Turn off the power switch. Remove the Hard Disk Drive and turn on the power switch.   |
|                               |   | <p> <b>Note</b></p> <p><input type="checkbox"/> If the Hard Disk Drive is not installed, you cannot send the sample print job, locked print job and download the font to Hard Disk Drive using the PS Utility for Mac.</p> |

| Messages/Second messages         | Description   | Solution   |
|----------------------------------|---|--|
| Hardware Problem<br>IEEE1394     | An error has occurred in the optional 1394 Interface Unit.    | First, turn the power switch off and then on, If the message appears again, call your sales or service representative.   |
|                                  |   | Turn off the power switch. Replace the 1394 Interface Unit and turn on the power switch. See "1394 Interface Unit Type 4510" in the Setup Guide.   |
|                                  |   | Turn off the power switch, remove the 1394 Interface Unit and turn on the power switch.<br><br><b>Note</b><br><input type="checkbox"/> If you remove the 1394 Interface Unit, you cannot send print jobs via the 1394 Interface Unit. You can only send print jobs to the printer via the parallel cable connection. |
| Hardware Problem<br>IEEE 802.11b | An error has occurred in the optional 802.11b Interface Unit. | Replace the IEEE 802.11b board.  |
| Hardware Problem<br>NV-RAM       | An error has occurred in the printer.                         | First, turn the power switch off and then on. If the message appears again, call your sales or service representative.   |
| Hardware Problem<br>Option RAM   | An error has occurred in the optional Memory Unit.            | First, turn the power switch off and then on. If the message appears again, call your sales or service representative.   |
|                                  |   | Turn off the power switch, Replace the Memory Unit, and then turn on the power switch. See "Memory Unit Type C" in the Setup Guide.  |

| Messages/Second messages           | Description   | Solution   |
|------------------------------------|---|--|
| Hardware Problem<br>Option RAM     | An error has occurred in the optional Memory Unit.                              | <p>Turn off the power switch, remove the Memory Unit, and then turn on the power switch.</p> <p> <b>Note</b></p> <ul style="list-style-type: none"> <li><input type="checkbox"/> If you remove the Memory Unit, you must set up the option with the printer driver. If you are using Windows 95/98/Me, Windows 2000/Windows XP/Server 2003 and Windows NT 4.0, see "Installing the Printer Driver and Software" in the Setup Guide.</li> <li><input type="checkbox"/> In this case, you might not be able to print complex print jobs.</li> </ul> |
| Hardware Problem<br>Shift Tray     | An error has occurred in the shift motor of the shift tray.                     | First, turn the power switch off and then on. If the message appears again, call your sales or service representative.   |
| Hardware Problem<br>Parallel I/F   | An error has occurred in the parallel I/F.                                      | If you use the parallel I/F, replace the interface cable that caused the error. If the message appears again, contact your sales or service representative.  |
| Hardware Problem<br>USB            | There is a problem related to the Universal Serial Bus Connection and Hardware. | First, turn the power switch off and then on, If the message appears again, call your sales or service representative.   |
| Hardware Problem<br>Wireless Board | An error has occurred in the 802.11b Interface Unit.                            | Reset the 802.11b Interface Unit if the same message appears after turning the power off and then back on again. If the same message still appears, contact your sales or service representative.  |
| Hardware Problem<br>Wireless Card  | An error has occurred in the 802.11b Interface Unit.                            | Reset the 802.11b Interface Unit if the same message appears after turning the power off and then back on again. If the same message still appears, contact your sales or service representative.  |

| Messages/Second messages        | Description  | Solution  |
|---------------------------------|--|---|
| HDD Full                        | The maximum HDD area size for form/font has been exceeded.   | Delete the disused form/font types.   |
| HDD Full                        | The optional Hard Disk Drive is full. The sample print job or locked print job to be sent from the computer is too large to store. | Delete any unnecessary stored files.  |
| HDD Not Installed               | You cannot print the sample print and the locked print jobs, because the optional Hard Disk Drive is not installed.                | Install the Hard Disk Drive. See "Hard Disk Drive Type 2600" in the Setup Guide.  |
| Hex Dump Mode                   | The printer is in Hex Dump Mode.   | Wait for a while. If the "Hex Dump Mode" message does not change, on the panel display press <b>[On Line]</b> to return to the "Ready" condition. |
| I/O Buffer Overflow             | There is too much data for the I/O buffer to handle.   | Make sure the interface cable is inserted into the printer and your computer securely.  |
|                                 |  | Make sure the interface cable is not damaged or broken.   |
|                                 |  | Increase the size of the I/O buffer.  |
| Internal Error                  | A read/write error occurred.   | Check the file is a valid PDF or not.   |
| Invalid Password File Protected | An incorrect password has been entered more than 10 times, the file is now protected until an administrator can unlock it.         | The file is now protected until an administrator can unlock it.   |
| Invalid Password Reconfirm      | When entering the confirmation password to set the new one, this message appears if an incorrect password is entered.              | Enter the correct password.   |
| Invalid Password Try Again      | The password was not entered correctly.  | Wait for two seconds until the previous display appears. Then enter the password correctly.   |

| Messages/Second messages                                   | Description  | Solution   |
|--|--|--|
| Load Correct<br>Size Paper<br>/Press #<br>to Continue      | The paper size setting on the tray differs from that of actual paper size in the tray.   | Load { paper size } paper of the selected feed direction and paper size into the tray. Printing will not automatically resume if the paper size and direction setting is incorrect. Make sure that the paper feed directions set in the printer driver and on the control panel are the same. There are two methods to resume printing.<br>① Use the control panel to set the correct paper size and direction of the paper in tray. Then press <b>【Enter #】</b> .<br>② Press <b>【Form Feed】</b> and select the tray with the control panel. |
| Load Paper /Max. Size Over<br>/(Paper type)                | This message will appear as an alternating message in conjunction with [Load Paper], (A4 Recycle), when a size selected at the driver (PC) side is larger than the maximum available size setting on the machine side, this message will be displayed. | Reset the job or print on the available paper as is.   |
| Load Paper<br>/Paper Size:<br>Paper Type:                  | The paper type and size settings for this tray do not match the size and type of paper actually loaded.  | Load paper into the tray indicated, then press <b>【Enter #】</b> to resume printing. Or press <b>【Form Feed】</b> and select the tray that holds a different type of paper. To cancel printing, press <b>【Job Reset】</b> . Then press <b>【Enter #】</b> .   |
| Load Paper Press # to print<br>/Paper Size:<br>Paper Type: | The printer detected that actual paper size is not the same as the dial setting. This error message appears at the second page of a job.   | Load the correct paper and then press <b>【Enter #】</b> to resume printing. To ignore the error message and continue printing, press <b>【Enter #】</b> .   |
| Load Paper Tray #<br>/Paper Size:<br>Paper Type:           | There is no paper left in this tray.   | Load paper into the tray indicated.  |
| Menu Protected<br>Cannot Change                            | The menu is protected and the settings cannot be changed.  | Wait for two seconds until the previous display appears.   |
| Memory Overflow  | The printer identified a PS3 display list overflow error.  | Increase RAM capacity.   |

| Messages/Second messages   | Description   | Solution  |
|--|---|---|
| No Files Exist   | There are no files available for the sample print job or the locked print job.  | Wait for two seconds until the previous display appears.  |
| No File System   | Cannot receive PDF data.  | Cannot print.   |
| No Log Exists  | The user has selected to print the error log in the List/Test Print mode, however no errors have been detected and so a log has not been created. |   |
| Offline  | The printer is offline.   | If you want to bring the printer online. Press <b>[On Line]</b> .   |
| Output Tray Changed  | The output tray has been changed. The tray in the paper feed path is not set correctly when the printer receives the print job.                   | Select the output tray correctly.   |
| P= XX I= XXXXXXXX<br>Power Off On<br>/If Error Reoccur<br>Call Service | A controller error. The SC number indicates the problem.  | First, turn the power switch off and then on. If the message appears again, call your sales or service representative.  |
| Paper Invalid for Duplex:Tray #<br>/Change Setting<br>or Form Feed     | A paper setting for the selected tray is not supported for duplex printing.<br>#: tray number   | Change the paper setting with the control panel. Or press <b>[Form Feed]</b> several times until a tray with supported paper settings appears on the panel display.<br>Or press <b>[Job Reset]</b> to cancel the print job. |
| Paper Invalid for Duplex:Tray #<br>/Change Setting<br>or Reset The Job |   |   |
| PDF Func. Denied   | A setting option when making the PDF denies printing permission PDF.  | Increase RAM capacity.  |
| Please wait...   | WEP settings are being changed and updated in this status message. The printer device keys are unoperational during this period.                  |   |
|  | The user is urged to wait while emulation is switching.   |   |



| Messages/Second messages  | Description  | Solution   |
|---|--|--|
| Print Overrun   | A Print overrun occurred on a file being printed. Only a part of the data on the page will be printed, and the print job is suspended, or the current print job has been canceled. | To print the image correctly, add memory to the printer or reduce the resolution of the image. |
| Printing...   | ————   | Wait for a while.  |
| Processing...   | The printer is processing internally.  | Wait for a while.  |
| Ready   | The printer is online and ready to make prints.  | If you want to take the printer offline, press <b>[On Line]</b> .                              |
| Remove Misfeed<br>Duplex Unit<br>/Open Duplex<br>Unit Cover     | There is misfeed in the Duplex Unit.   | Remove the misfed paper.   |
| Remove Misfeed<br>Internal Path<br>/Open Front Cover            | There is a misfeed in the printer.   | Remove the misfed paper. See p.101 "Removing Misfed Paper".                                    |
| Remove Misfeed<br>Mailbox<br>/Open<br>Mailbox Cover             | There is a misfeed in the Mailbox.   | Remove the misfed paper.   |
| Remove Misfeed<br>Paper Exit Cover<br>/Open Paper<br>Exit Cover | There is a misfeed in the paper exit cover.  | Remove the misfed paper.   |
| Remove Misfeed<br>Paper Tray<br>/Remove Misfeed<br>Paper Tray   | There is a misfeed in the printer.   | Remove the misfed paper. See p.101 "Removing Misfed Paper".                                    |
| Remove Misfeed<br>Upper Tray Unit<br>/Open Upper<br>Tray Cover  | There is a misfeed in the upper tray unit.   | Remove the misfed paper.   |
| Remove Paper<br>All Output Trays                                | All output trays are full, and the print job is suspended.   | Remove paper from all output trays, and the print job will be resumed automatically.           |
| Remove Paper<br>from Upper Tray                                 | The upper tray is full, and the print job is suspended.  | Remove paper from the upper tray, and the print job will be resumed automatically.             |

| Messages/Second messages    | Description   | Solution  |
|-----------------------------|---|---|
| Remove Paper Mailbox Tray # | The Mailbox is full, and the print job is suspended.  | Remove paper from the Mailbox, and the print job will be resumed automatically.   |
| Remove Paper Standard Tray  | The standard tray is full, and the print job is suspended.  | Remove paper from the standard tray, and the print job will be resumed automatically.   |
| Replace Maintenance Kit     | It is time to replace parts included in the Maintenance Kit.  | Replace parts. See p.178 "MAINTENANCE KIT Type 600".  |
| Replace Toner Cartridge     | The toner cartridge is not set correctly or toner is almost run out.  | Set the toner cartridge correctly. See p.110 "Replacing the Toner Cartridge".   |
|                             | The toner dust is full.   | Prepare a new toner cartridge. If the image density gets too light, replace the toner cartridge with a new one. See p.110 "Replacing the Toner Cartridge".                  |
| Reset Duplex Unit Correctly | A communication error sent from the system unit to the duplex unit.   | Set the duplex unit correctly. If the problem persists, call your service provider.   |
| Reset Fusing Unit Correctly | The fusing unit is not set correctly.   | Set the fusing unit correctly, or set the proper fusing unit.   |
| Reset Toner Cartridge       | The toner cartridge is not set correctly.   | Set the toner cartridge correctly. See p.110 "Replacing the Toner Cartridge".   |
|                             | The toner cartridge is not set installed.   | If the cartridge is installed, close the front cover and turn the off power switch and then on. If the message appears again, contact your sales or service representative. |
| Reset Tray # Correctly      | The input paper tray is not set correctly.  | Set the input paper tray correctly.   |
| Resetting Job...            | The print job is being reset.   | Wait for a while.   |
| RPCS Graphic Error          | The graphics is not initialized because the graphics memory was not reserved. This error rarely occurs unless the printer detects the memory failure. Please note that "RPCS"(RICOH printer language) is the same worldwide and does not need to be translated. | Replace the installed memory.   |

| Messages/Second messages                                     | Description  | Solution   |
|--|--|--|
| RPCS Syntax Error  | The printer identified a syntax error. This error results from; data transmogrification caused by the transmission path problem, data interruption, data transmission from other drivers, etc. | Be sure to use the correct driver.   |
| RPCS Memory Overflow   | The printer memory is not initialized because the CDC memory was not reserved via the system call. This error rarely occurs.   | Replace the installed memory.  |
| SC XXX-X<br>Power Off On<br>If Error Reoccur<br>Call Service | An error has occurred.   | First, turn the power switch off and then on. If the message appears again, call your sales or service representative.                                     |
| SC2001   | An error has occurred in the resident font RAM.  | First, turn the power switch off and then on. If the message appears again, call your sales or service representative.                                     |
| Setting change in process                                    | A setting change is currently in process on the computer side.   | The user must wait until the change is complete.   |
| Setting changed Restart Printer                              | <b>[RAM Disk]</b> or <b>[Notify by E-mail]</b> setting has been changed.   | Restart the printer so the new settings can take effect.   |
| Toner Is Almost Empty  | The toner is almost run out.   | Prepare a new toner cartridge. If the image density gets too light, replace the toner cartridge with a new one. See p.110 "Replacing the Toner Cartridge". |
| User Code is incorrect                                       | An incorrect or invalid user code was entered.   | Enter the correct user code.   |
| Waiting...   | The printer is waiting for the next print job.   | Wait for a while.  |
| Warming Up...  | The printer is warming up or toner is being supplied.  | Wait until the panel display change the "Ready".   |

## Getting Printer Information over the Network

### Printer current status

You can check the printer's status using the telnet command.

❖ **telnet**

Use the status command.

❖ **UNIX**

Use the lpq or lpstat command or stat parameter of rsh, rcp, or ftp.

 **Reference**

For more information, see “Remote Maintenance by Telnet (mshell)” in the Network Printing Guide is provided on the CD-ROM labeled “Operating Instructions”.

5

| Messages                    | Description  | Comments   |
|-----------------------------|--|--|
| Call Service Center         | There is a malfunction in the printer.                     | Turn the printer off and on.   |
| Cover Open: Duplex Unit     | The cover of the optional Duplex Unit is open.             | Close the cover of the optional Duplex Unit.   |
| Cover Open: Front Cover     | Close the front cover.                                     | Close the front cover.   |
| Cover Open: Mailbox         | The cover of the Mailbox is open.                          | Close the cover of the Mailbox cover.  |
| Cover Open: Paper Exit/Rear | The paper exit cover or the rear cover is open.            | Close the paper exit cover or the rear cover.  |
| Cover Open: Upper Tray      | The upper tray cover is open.                              | Close the upper tray cover.  |
| Empty: Toner                | The toner cartridge is empty.                              | Replace the new toner cartridge.   |
| Energy Saver Mode           | The printer is in Energy Save Mode.                        | Wait for a while.  |
| Energy Saver Mode 1         |  |  |
| Error: HDD Board            | An error has occurred in the optional Hard Disk Drive.     | First, turn the power switch off and then on. If the message appears again, call your sales or service representative. |
| Error: IEEE 1394 Board      | An error has occurred in the optional 1394 Interface Unit. | First, turn the power switch off and then on. If the message appears again, call your sales or service representative. |
| Error: Memory Switch        | An error has occurred in printer.                          | First, turn the power switch off and then on. If the message appears again, call your sales or service representative. |

| Messages                         | Description  | Comments  |
|----------------------------------|--|---|
| Error: Optional RAM              | An error has occurred in the optional Memory Unit.   | First, turn the power switch off and then on. If the message appears again, call your sales or service representative.  |
| Error: Parallel I/F Board        | An error has occurred in the parallel interface board.                                     | First, turn the power switch off and then on. If the message appears again, call your sales or service representative.  |
| Error: USB I/F                   | An error has occurred in the USB interface.  | First, turn the power switch off and then on. If the message appears again, call your sales or service representative.  |
| Full: Mailbox Tray 1             | The output tray 1 of the optional Mailbox is full.   | Remove paper from the output tray 1 of the optional Mailbox.  |
| Full: Mailbox Tray 2             | The output Tray 2 of the optional Mailbox is full.   | Remove paper from the output Tray 2 of the optional Mailbox.  |
| Full: Mailbox Tray 3             | The output Tray 3 of the optional Mailbox is full.   | Remove paper from the output Tray 3 of the optional Mailbox.  |
| Full: Mailbox Tray 4             | The output tray 4 of the optional Mailbox is full.   | Remove paper from the output tray 4 of the optional Mailbox.  |
| Full: Output Tray(s)             | All output trays are full.   | Remove paper from all output trays.   |
| Full: Standard Output Tray       | The output tray is full.   | Remove paper from output trays.   |
| Full: Waste Toner                | The toner is almost run out.   | Prepare a new toner cartridge.  |
| IEEE 802.11b Card Error          | The optional IEEE 802.11b board or the optional IEEE 802.11b card is not installed.        | Install the optional IEEE 802.11b board or the optional IEEE 802.11b card.  |
| IEEE 802.11b Card Error          | The optional IEEE 802.11b board or the optional IEEE 802.11b card is not installed.        | Install the optional IEEE 802.11b board or the optional IEEE 802.11b card.  |
| IEEE 802.11b Card or Board Error | An error has occurred in the optional IEEE 802.11b board or the optional IEEE 802.11b card | First, turn the power switch off and then on. If the message appears again, set the optional IEEE 802.11b board. If the message still appears, call your sales or service representative. |

| Messages                      | Description  | Comments  |
|-------------------------------|--|---|
| Low: Toner                    | The toner cartridge is not set correctly or toner is almost running out.               | Set the toner cartridge correctly.  |
| Mismatch: Paper Size          | The paper size setting of the tray differs from that of actual paper size in the tray. | Load paper of the indicated paper size into the paper tray being used. See p.37 "Paper and Other Media Supported by This Printer".          |
| Mismatch: Paper Size and Type | The paper type setting of the tray differs from that of actual paper type in the tray. | Load paper of the indicated paper size and type into the paper tray being used. See p.37 "Paper and Other Media Supported by This Printer". |
| Mismatch: Paper Type          | The paper type setting of the tray differs from that of actual paper type in the tray. | Load paper of the indicated paper type into the paper tray being used. See p.37 "Paper and Other Media Supported by This Printer".          |
| No Paper: Input Tray(s)       | There is no paper of the indicated paper size in the paper tray.                       | Load paper into the paper tray. See p.49 "Loading Paper in the Paper Tray".   |
| Not Detected: Fusing Unit     | The fusing unit is not set correctly.  | Set the fusing unit correctly. If the message appears again, call your sales or service representative.                                     |
| Not Detected: Input Tray(s)   | The input tray is not set correctly.   | Set the input tray correctly. If the message appears again, call your sales or service representative.                                      |
| Not Detected: Toner Cartridge | The toner cartridge is not set correctly.  | Set the toner cartridge correctly. If the message appears again, call your sales or service representative.                                 |
| NVRAM Error                   | An error has occurred in the printer.  | First, turn the power switch off and then on. If the message appears again, call your sales or service representative.                      |
| Paper Misfeed: Duplex Unit    | There is misfeed in the Duplex Unit.   | Remove the misfed paper. See p.106 "When "Remove Misfeed Duplex Unit" Appears".   |
| Paper Misfeed: Front Cover    | There is misfeed in the printer.   | Remove the misfed paper. See p.102 "When "Remove Misfeed Internal Path/Open Front Cover" Appears".  |

| Messages                   | Description  | Comments  |
|----------------------------|--|---|
| Paper Misfeed: Input Tray  | There is misfeed in the printer.   | Remove the misfed paper. See p.102 "When "Remove Misfeed Paper Tray" Appears".  |
| Paper Misfeed: Mailbox     | There is misfeed in the Mailbox.   | Remove the misfed paper. See p.108 "When "Remove Misfeed Mailbox" Appears".   |
| Paper Misfeed: Output Tray | There is misfeed in output tray.   | Remove the misfed paper. See p.104 "When "Remove Misfeed Paper Exit Cover" Appears".  |
| Ready                      | The printer is on line and ready to make prints.                                       | ————  |
| Replace Maintenance Kit    | It is time to replace parts included in the Maintenance Kit.                           | Replace parts. See p.178 "MAINTENANCE KIT Type 600".  |
| Shift Tray Error           | An error has occurred in the 1-bin Shift Sort Tray.                                    | First, turn the power switch off and then on. If the message appears again, call your sales or service representative.                      |
| Size Media Mismatch        | The paper size setting of the tray differs from that of actual paper type in the tray. | Load paper of the indicated paper size and type into the paper tray being used. See p.37 "Paper and Other Media Supported by This Printer". |
| Size Mismatch              | The paper size setting of the tray differs from that of actual paper type in the tray. | Load paper of the indicated paper size and type into the paper tray being used. See p.37 "Paper and Other Media Supported by This Printer". |
| Warming Up/Adjusting...    | The printer is warming up or toner is being supplied.                                  | Wait until the panel display change the "Ready".  |

## Printer configuration

You can check the printer configuration using telnet.

❖ **telnet**

Use the info command.

❖ **UNIX**

Use the info parameter of rsh, rcp, or ftp.

 **Reference**

For more information, see “Remote Maintenance by Telnet (mshell)” in the Network Printing Guide is provided on the CD-ROM labeled “Operating Instructions”.

 **Note**

“\*” (asterisk) is displayed with the current setting.

Regarding \*1–\*6, see below table.



























| Item   | Description  |
|--|--|
| Printer System                                   | Version of the printer   |
| Network Board                                    | Version of the network board   |
| Input Tray<br>No.<br>Name<br>PaperSize<br>Status | ID number of the paper tray<br>Name of the paper tray* <sup>1</sup><br>Paper size loaded in the paper tray* <sup>2</sup><br>Current status of the paper tray* <sup>3</sup> |
| Output Tray<br>No.<br>Name<br>Status             | ID number of the output tray<br>Name of the output tray* <sup>4</sup><br>Current status of the output tray* <sup>5</sup>   |
| Emulation<br>No.<br>Name<br>Version              | ID number of the emulation used by the printer<br>Name of the emulation used in the printer<br>Version of the emulation  |
| Program<br>No.<br>Name                           | ID number of the program<br>Name of the program  |

❖ **\*1 Input Tray: Name**

| Name        | Description  |
|-------------|--|
| Tray X      | Name of installed paper tray. (X is the number of tray.) |
| Bypass Tray | Bypass Tray  |



## ❖ \*2 Input Tray: Paper Size

| Paper Size   | Description  |
|--|--|
| A3 (297 × 420)   | A3    |
| B4JIS (257 × 364)  | B4    |
| A4 (297 × 210)   | A4    |
| A4 (210 × 297)   | A4    |
| B5JIS (257 × 182)  | B5    |
| B5JIS (182 × 257)  | B5    |
| A5 (210 × 148)   | A5    |
| A5 (148 × 210)   | A5    |
| A6 (105 × 148)   | A6    |
| 11 × 17  | 279 × 432   |
| 8 <sup>1</sup> / <sub>2</sub> × 14                             | LG/216 × 356    |
| 11 × 8 <sup>1</sup> / <sub>2</sub>                             | LT/279 × 216    |
| 8 <sup>1</sup> / <sub>2</sub> × 11                             | LT/216 × 279    |
| 5 <sup>1</sup> / <sub>2</sub> × 8 <sup>1</sup> / <sub>2</sub>  | 140 × 216   |
| FRI  | Custom Size  |
| 10 <sup>1</sup> / <sub>2</sub> × 7 <sup>1</sup> / <sub>4</sub> | 10 <sup>1</sup> / <sub>2</sub> × 7 <sup>1</sup> / <sub>4</sub>    |
| 7 <sup>1</sup> / <sub>4</sub> × 10 <sup>1</sup> / <sub>2</sub> | 7 <sup>1</sup> / <sub>4</sub> × 10 <sup>1</sup> / <sub>2</sub>  |
| 8 <sup>1</sup> / <sub>4</sub> × 13                             | 8 <sup>1</sup> / <sub>4</sub> × 13                              |
| 8 <sup>1</sup> / <sub>2</sub> × 13                             | 8 <sup>1</sup> / <sub>2</sub> × 13                              |
| 4 <sup>1</sup> / <sub>8</sub> × 9 <sup>1</sup> / <sub>2</sub>  | 4 <sup>1</sup> / <sub>8</sub> × 9 <sup>1</sup> / <sub>2</sub>   |
| 3 <sup>7</sup> / <sub>8</sub> × 7 <sup>1</sup> / <sub>2</sub>  | 3 <sup>7</sup> / <sub>8</sub> × 7 <sup>1</sup> / <sub>2</sub>   |
| 110 × 220  | 4 <sup>1</sup> / <sub>3</sub> × 8 <sup>3</sup> / <sub>4</sub>   |
| C5 Env (162 × 229)   | C5 Env    |
| 8 × 13   | 203 × 330   |
| C6 Env (114 × 162)   | C6 Env    |
| 8K (267 × 390)   | 8K    |
| 16K (267 × 195)  | 16K   |
| 16K (195 × 267)  | 16K   |
| NCS  | There is no tray.  |
| **   | The paper size is not selected.  |

❖ **\*3 Input Tray: Status**

| Status   | Description                         |
|----------|-------------------------------------|
| Normal   | —                                   |
| NoTray   | There is no paper tray              |
| PaperEnd | There is no paper in the paper tray |

❖ **\*4 Output Tray: Name**

| Name             | Description             |
|------------------|-------------------------|
| Standard Tray    | Output Tray             |
| 1-bin Shift Tray | 1-bin Shift Sort Tray   |
| Mailbox Tray 1-4 | Mailbox output tray 1-4 |



❖ **\*5 Output Tray: Status**



| Status     | Description                       |
|------------|-----------------------------------|
| Normal     | ----                              |
| PaperExist | There is paper in the output tray |
| OverFlow   | Output tray is full of paper      |
| Error      | Other error                       |

# Printer Does Not Print

| Possible Cause  | Solutions   |
|---|---|
| Is the power on?  | Confirm that the cable is securely plugged into the power outlet and the printer.<br>Turn on the power switch.  |
| Does the <b>On Line</b> indicator stay on?  | Press <b>[On Line]</b> so the indicator lights.   |
| Does the <b>Error</b> indicator stay red?   | Check the error message on the panel display and take the required action.  |
| Is paper loaded?  | Load paper into the paper tray or on the Bypass Tray.<br>See p.49 "Loading Paper and Other Media".  |
| Can you print a configuration page?   | If you cannot print a test page, it probably indicates a printer malfunction. You should contact your sales or service representative. See p.130 "List/Test Print Menu".<br><br>If you can print a test page but cannot get the printer to print when you issue a print command from the computer, it probably means there is a problem with the computer.<br><br>Note that large or complex data might take a long time to be printed. |
| Is the interface cable connecting the printer to the computer connected securely? | Connect the interface cable properly. If there are any connectors or screws, confirm that they are fastened securely.   |
| Are you using the correct interface cable?  | The type of interface cable you should use depends on the computer. Be sure to use the correct one.<br>If the cable is damaged or worn, replace it with a new one.  |
| Is the paper feed roller clean?   | Clean the paper feed roller if it is dirty. See p.114 "Cleaning the Paper Feed Roller".   |

| Possible Cause   | Solutions   |
|--|---|
| <p>Is the <b>Data In</b> indicator blinking or lit after starting the print job?</p> | <p>If not blinking or lit, the data is not being sent to the printer.</p> <ul style="list-style-type: none"> <li>❖ <b>If the printer is connected to the computer using the interface cable</b><br/>                     Make sure the following printer port settings are correct:                     <ul style="list-style-type: none"> <li>• For a parallel port connection, port LPT1 or LPT2 should be set.</li> <li>• For a USB port connection, port USB00 (n) *1 should be set.</li> <li>• For a IEEE 1394 (SCSI print) port connection, port 1394_00(n) *1 should be set.</li> </ul>                     *1 (n) is the number of printers connected.                     <ul style="list-style-type: none"> <li>• <b>Windows 95/98/Me</b> <ol style="list-style-type: none"> <li>① Click <b>[Start]</b>, point to <b>[Settings]</b> and then click <b>[Printers]</b>.</li> <li>② Click to select the icon of the printer. Next, on the <b>[File]</b> menu, click <b>[Properties]</b>.</li> <li>③ Click the <b>[Details]</b> tab.</li> <li>④ Check the <b>[Print to the following port]</b> box to confirm that the correct port is selected.</li> </ol> </li> <li>• <b>Windows 2000</b> <ol style="list-style-type: none"> <li>① Click <b>[Start]</b>, point to <b>[Settings]</b> and then click <b>[Printers]</b>.</li> <li>② Click to select the icon of the printer. Next, on the <b>[File]</b> menu, click <b>[Properties]</b>.</li> <li>③ Click the <b>[Port]</b> tab.</li> <li>④ Check the <b>[Print to the following port]</b> box to confirm that the correct port is selected.</li> </ol> </li> <li>• <b>Windows XP/Server 2003</b> <ol style="list-style-type: none"> <li>① Access the <b>[Printers and Faxes]</b> window from <b>[Start]</b> on the taskbar.</li> </ol> </li> </ul> <p> <b>Note</b></p> <ul style="list-style-type: none"> <li>❑ With Windows XP Home Edition, open <b>[Control panel]</b> from <b>[Start]</b>, click <b>[Printers and Other Hardware]</b>, and then click <b>[Printers and Faxes]</b> on the screen that appears.</li> <li>② Click to select the icon of the printer. Next, on the <b>[File]</b> menu, click <b>[Properties]</b>.</li> <li>③ Click the <b>[Port]</b> tab.</li> <li>④ Check the <b>[Print to the following port(s.)]</b> box to confirm that the correct port is selected.</li> </ul> <ul style="list-style-type: none"> <li>• <b>Windows NT 4.0</b> <ol style="list-style-type: none"> <li>① Click <b>[Start]</b>, point to <b>[Settings]</b> and then click <b>[Printers]</b>.</li> <li>② Click to select the icon of the printer. Next, on the <b>[File]</b> menu, click <b>[Properties]</b>.</li> <li>③ Click the <b>[Port]</b> tab.</li> <li>④ Check the <b>[Print to the following port]</b> box to confirm that the correct port is selected.</li> </ol> </li> </ul> </li> </ul> |

| Possible Cause  | Solutions  |
|---|--|
| Is the <b>Data In</b> indicator blinking or lit after starting the print job? | <p>❖ <b>Network Connection</b><br/>Contact your network administrator.</p>   |
| Do you print via a network?   | <p>Confirm that the "Ethernet" setting is correct from the control panel. See p.156 "Host Interface Menu".</p> <p>The setting governs the data transfer speed used by the Network Interface Board. Three options are available:</p> <ul style="list-style-type: none"> <li>• Auto (default)</li> <li>• 100 Mbps</li> <li>• 10 Mbps</li> </ul> <p> <b>Note</b></p> <p><input type="checkbox"/> For more information about the appropriate setting to use on your network, contact your network administrator.</p>  |
| If you use IEEE 1394, check for the followings.                               | <p>① Make sure the 1394 Interface Unit is installed properly.</p> <p>② Make sure the IEEE 1394 cable is connected properly.</p> <p>③ Restart the computer.<br/>If the problem still exists when SCSI print is used with Windows 2000 and Windows XP/Server 2003, go to step ④.</p> <p>④ Disconnect all the IEEE 1394 cables from the computer.</p> <p>⑤ If you uninstall the printer driver when the printer is connected to a computer with "SCSI print", the printer driver may not be uninstalled properly. To uninstall the driver properly, use the IEEE 1394 Printer Removal Utility on the CD-ROM that comes with the printer.<br/>Stored in: CD-ROM labeled "Operating Instructions"\DRIVERS\ UTILITY\1394\<br/><br/> <b>Note</b></p> <p><input type="checkbox"/> For more information about the IEEE 1394 Printer Removal Utility, see the README file in the same folder as the program.</p> <p>⑥ Restart the computer.</p> |
| How is the signal strength when using the wireless LAN?                       | <p>❖ <b>Ad Hoc Mode or 802.11 Ad Hoc Mode</b><br/>Either move to a location where the signal is good, or remove obstructions.</p> <p>❖ <b>Infrastructure Mode</b><br/>Check the signal status from the "Maintenance" menu on the control panel. See p.143 "Displaying the Signal Strength". If the signal is poor, either move to a location where it is good, or remove obstructions.</p>   |

| Possible Cause  | Solutions  |
|---|--|
| How is the signal strength when using Bluetooth™?                                       | <p>Try the following:</p> <ul style="list-style-type: none"> <li>• Check the Bluetooth Interface Unit is installed properly.</li> <li>• Check there are no obstructions between computer and printer.</li> <li>• Change the location of the computer.</li> <li>• Change the location of the printer.</li> </ul>  |
| PDF Direct Print is not executed (PDF file is not printed).                             | <p>You must install an optional hard disk drive or set the value of the <b>[RAM Disk]</b> in the System Menu to 2 MB or higher.</p> <p> <b>Reference</b><br/>See "Hard Disk Drive Type 2600", Setup Guide for optional hard disk drive installation.</p>  |
|   | <p>After adding a memory unit and set the value of the <b>[RAM Disk]</b> in the System Menu to 16 MB, value of the <b>[RAM Disk]</b> returns to 0 MB if the memory unit is removed. If this happens, reset the value of the <b>[RAM Disk]</b> to 2 MB or higher.</p> <p> <b>Reference</b><br/>For <b>[RAM Disk]</b>, see the p.148 "System Menu".</p> |
|   | <p>When printing a PDF with a password set, set the password of the PDF file using the <b>[PDF: Change PW]</b> menu in <b>[PDF Menu]</b> or Web Image Monitor.</p> <p> <b>Reference</b><br/>For <b>[PDF: Change PW]</b>, see the p.171 "PDF Menu".<br/>For Web Image Monitor, see Help.</p>  |
|   | <p>Due to the security setting of the PDF file, when <b>[Printing]</b> under <b>[Do not Allow]</b> of a PDF file is checked, the file cannot be printed. Perform printing after unchecking the <b>[Printing]</b> of <b>[Do not Allow]</b>.</p>   |
| As a result of printing using PDF Direct Printing, characters are missing or misshapen. | Before printing, embed the font in the PDF file to be printed.   |

 **Note**

- If you cannot solve the problem by taking the preceding actions, contact your sales or service representative.

# Other Printing Problems

| Status                                       | Possible Causes, Descriptions, and Solutions   |
|--|--|
| The print side of the page is a hazy gray.   | Adjust the image density.<br>See p.121 "Making Printer Settings with the Control Panel".   |
|  | If paper is curled, correct it.  |
|  | If you continuously print data that contains extremely small amount of words or images in the printable area, the printed side of the page could be a hazy gray. Adjust the image density. See p.121 "Making Printer Settings with the Control Panel".   |
|  | Shaking the toner cartridge after pulling out the toner seal can cause dirt on paper surfaces, toner spillage, or printer failure. If you have accidentally shaken the toner cartridge, print some pages (about 50 pages) until the dirt disappear.  |
| The paper's reverse side is dirty.           | Paper loaded in the Paper Tray or Paper Feed Unit may not match the paper size dial setting. Set the paper size dial so it matches the size and feed direction of the paper in the tray. See p.49 "Loading Paper in the Paper Tray".<br>The size and feed direction of paper in the Bypass Tray may not match the control panel settings. Check the control panel settings so they match the size and feed direction of the paper in the tray.<br>See p.52 "Loading Paper in the Bypass Tray". |
|  | The next sheet of paper printed may have a dirtied reverse side if the data size is larger than the paper being printed onto, such as A4 data onto B5 paper.   |
|  | Image quality varies when printing on thick paper or on OHP transparencies.  |
| Some parts of the print image are not clear. | Switch to Thick Paper mode.<br><ul style="list-style-type: none"> <li>• When toner is not fused enough, set it to "On".</li> <li>• When the image is blurred, set it to "----".</li> </ul> See p.121 "Making Printer Settings with the Control Panel".   |
|  | If Toner Saving mode is selected using the control panel, the whole image gets lighter.  |
| The print image is not clear.                | Due to a sudden change in temperature, condensation might appear inside the printer, reducing print quality. If this occurs, when you move the printer from a cold room to a warmer room, do not use the printer until it acclimatizes to the temperature.   |

| Status  | Possible Causes, Descriptions, and Solutions   |
|---|--|
| Nothing is printed on the paper.  | <p>Check if the tape of the toner cartridge is completely removed. Be sure to remove the tape completely when replacing the toner cartridge. See p.110 "Replacing the Toner Cartridge".</p> <p> <b>Note</b></p> <p><input type="checkbox"/> If the power switch is turned on with the tape still attached to the toner cartridge, the printer might be damaged.</p> |
| Multiple pages are fed through the printer at once.                       | Clean the friction pad if it is dirty. See p.113 "Cleaning the Friction Pad".  |
|   | Remove all paper from the tray and fan it gently to get air between the sheets. After that, load it back into the tray.  |
| The image is printed on the reverse side of the paper.                    | Set the paper the other way up.  |
| Paper misfeeds occur frequently.  | Check the paper size settings. The size set with the paper size dial might be different from the actual paper size. Make the correct dial setting.<br>See p.49 "Loading Paper and Other Media".  |
|   | Use the recommended paper. Avoid using curled, folded, wrinkled, perforated or glossy paper. See p.47 "Paper not supported by this printer".   |
|   | Clean the paper feed roller, friction pad and/or registration roller, if they are dirty. See p.114 "Cleaning the Paper Feed Roller".   |
|   | Thin paper, if printed on both sides, may curl up at the corners and get wrinkled and clogged. Select <b>[Curl Prevention] [ON]</b> from the <b>[Maintenance]</b> menu.  |
| The control panel error message stays on after removing the misfed paper. | Open the front cover of the printer and then close it. See p.101 "Removing Misfed Paper".  |
| Output are not delivered to the selected tray you require.                | Check the paper size settings. The size selected with the paper size dial might be different from the actual paper size. Make the correct dial setting.<br>See p.49 "Loading Paper and Other Media".   |
|   | When using the Bypass Tray, set the paper size using the control panel.<br>See p.49 "Loading Paper and Other Media".   |
|   | When you are using a Windows operating system, the printer driver settings override those set using the control panel. Set the desired output tray using the printer driver. See the driver's online Help file.  |
| The printed image is different from the image on the computer.            | When you use some functions, such as enlargement and reduction, the layout of the image might be different from that shown in the computer display.  |



| Status   | Possible Causes, Descriptions, and Solutions   |
|--|--|
| It takes too much time to resume printing.   | The data is so large or complex that it takes time to process it. If the <b>Data In</b> indicator is blinking, the data processing is being done. Just wait until it resumes.  |
|  | Changing the paper feed direction may sometimes reduce the time to resume printing.  |
| The image is printed in the wrong orientation.   | Set the correct orientation under the "PCL Menu" with the control panel. See p.164 "PCL Menu".   |
|  | Confirm that the setting of orientation has been set in the application you use.   |
|  | Set the correct paper size and feed direction that matches tray settings on the RPCS printer driver.   |
| Part of the image cannot be printed.   | A paper size which is smaller than that selected in the application is used for printing. Load the correct size of paper.  |
| Network configurations you have made do not become effective.  | Print a configuration page and check the network settings.   |
| A portion of the image is not printed or an error occurred in the PostScript printer driver when printing with PCL or the PostScript printer driver. | <p>You can print using the procedure below.</p> <ul style="list-style-type: none"> <li>Set <b>[Memory Usage]</b> in the System Menu to <b>[Font Priority]</b> on the control panel.</li> </ul> <p><b>Important</b></p> <ul style="list-style-type: none"> <li><input type="checkbox"/> Return the setting to <b>[Frame Priority]</b> after you have finished printing. If the setting is left as <b>[Font Priority]</b>, continuous printing speed may decrease, two-sided printing may be canceled or a job reset may occur during continuous printing.</li> <li>If the entire image is not printed out properly even after changing the above setting, add an additional memory unit.</li> </ul> |
| The paper size appears on the control panel and printing is not performed with PDF Direct Print.   | <p>When using PDF Direct Print, printout requires paper set within the PDF file. When a message indicating a paper size appears, either place the indicated size in the paper tray, or perform Form Feed.</p> <p>Also, if <b>[Sub Paper Size]</b> in the System Menu is set to <b>[ON]</b>, printing is performed assuming letter size and A4 size to be the same size. For example, When a PDF file set to A4 size paper is printed using PDF Direct Print and letter size paper is installed in the paper tray, the file will print out. This applies similarly to the opposite case.</p>  |
| No e-mail is received when an Alert occurs, and after resolving an Alert.  | Confirm <b>[Notify by E-Mail]</b> is <b>[On]</b> using the System Menu on the Control Panel. See p.148 "System Menu".  |
|  | <p>Access the printer through the Web Browser, log on as an Administrator on the Web Image Monitor, and then confirm the following settings in <b>[Notification]</b>:</p> <ul style="list-style-type: none"> <li>Device E-mail Address</li> <li>Groups to Notify</li> <li>Select Groups/Items to Notify</li> </ul> <p>See Web Image Monitor Help for details about the settings.</p>   |

| Status  | Possible Causes, Descriptions, and Solutions  |
|---|---|
| No e-mail is received when an Alert occurs, and after resolving an Alert  | Access the printer through the Web Browser, log on as an Administrator on the Web Image Monitor, and then confirm the settings of the SMTP server in <b>[E-mail]</b> . See Web Image Monitor Help for details about the settings.   |
|   | When the power is turned off before the e-mail is transmitted, the e-mail will not be received.   |
|   | Check the e-mail address set for the destination. Confirm the printer's operation history using the Web Image Monitor's System Log menu in <b>[Network]</b> . If the e-mail was sent but not received, it is possible the destination was incorrect. Also check the information concerning error mail from the e-mail server.   |
| The setting for <b>[Notify by E-Mail]</b> on the System Menu was changed from <b>[Off]</b> to <b>[On]</b> , but e-mail is not arriving.             | After changing the setting, turn the main unit's power off and then back on again.  |
| Error notification e-mail was received, but no error-solved e-mail is received.   | Check e-mail is set for sending using the Web Image Monitor's <b>[Notification]</b> at the time the error was fixed. You must click the <b>[Edit]</b> button of <b>[Detailed Settings of Each Item]</b> in <b>[Notification]</b> , and set <b>[Notify when Error]</b> to <b>[Occurs &amp; Fixed]</b> on the displayed screen. See of the Web Image Monitor Help for details about the settings.                                 |
| Alert Resolving is set for sending e-mail, but no Alert-resolved e-mail is sent.  | If the power of the main unit is turned off after an Alert occurs, the Alert is resolved during the time the power is off: no Alert-resolved e-mail is sent.  |
| Alert Occurrence and Alert Resolving are set for sending e-mail, but while no Alert Occurrence mail is received, Alert-resolved e-mail is received. | Alert-notification e-mail is not sent if the problem is resolved before sending. However, an Alert-resolved e-mail is sent.   |
| Alert-notification level was changed, and e-mail stopped arriving.  | If an Alert-notification e-mail, set with the earlier notification level, arrives, later e-mail will not be sent, even if the notification level is changed after. For example: the toner remaining notification level is 30% and e-mail arrives accordingly, if it is changed to 20%, no e-mail arrives when the toner remaining level reaches 20%. However, once the toner is changed, the new notification level is applied. |
| When no date information is included in sent e-mail, the mail server has a malfunction.   | Make the setting for obtaining time information from the SNTP server. Refer to the Web Image Monitor's Help to the settings.  |
|   | When there is no timeserver, set <b>[E-mail Date]</b> to <b>[On]</b> using the Control Panel's <b>[System Menu]</b> .   |

 **Note**

If the problem cannot be solved, contact your sales or service representative.

# Removing Misfed Paper

When a paper misfeed occurs, an error message appears on the panel display. The procedure you should follow to remove misfed paper depends on the location of the misfeed, which is indicated on the panel display.

**⚠ CAUTION:**

- *When removing misfed paper, do not touch the fusing section because it becomes very hot.*

**🔧 Important**

- Check the following points if paper continues to misfeed.
  - Confirm that the setting of the paper size dial matches the size and feed direction of the paper loaded in the paper tray.
  - If the friction pad or the paper feed roller is dirty, clean it. For more information, see p.113 “Cleaning the Friction Pad”.
  - Confirm that the toner cartridge is set correctly.
- If a paper misfeed still occurs, contact your sales or service representative.
- Forcefully removing misfed paper may cause paper to tear and leave scraps of paper in the printer.
- Do not leave any scraps of paper in the printer.

## When "Remove Misfeed Paper Tray" Appears

### Important

- ❑ Forcefully removing misfed paper may cause paper to tear and leave scraps of paper in the printer. This might cause a misfeed and damage the printer.

- 1 Lift the paper tray slightly. Pull it out until it stops, and then remove the misfed paper.

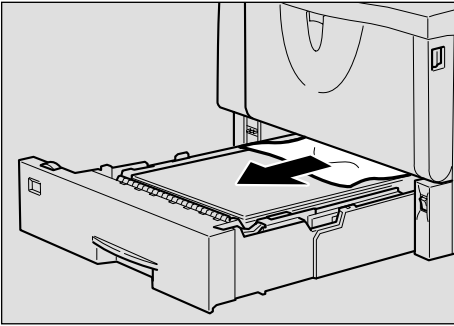

ZKGY280E

- 2 Carefully slide the paper tray into the printer until it stops.

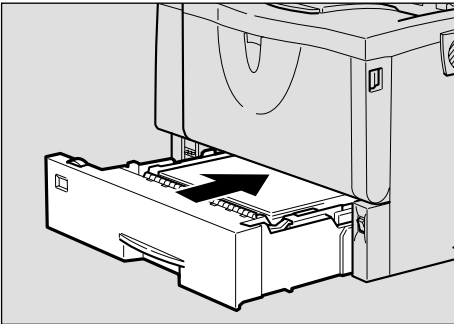

ZKGY280E

### Important

- ❑ Do not slide the paper tray in with force. If you do, the front and side guides might move.

- 3 Open the front cover by pushing the front cover release button, and then close it to reset the misfeed condition.

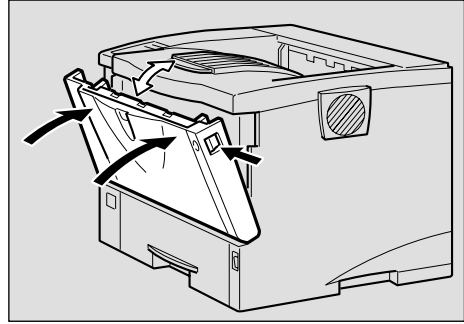

ZKGY300E

### Note

- ❑ You can apply this procedure for both the paper tray and the optional Paper Feed Unit.
- ❑ To reset the misfeed condition, open and close the front cover, then the indicator will be off.

## When "Remove Misfeed Internal Path/Open Front Cover" Appears

### Important

- ❑ Forcefully removing misfed paper may cause paper to tear and leave scraps of paper in the printer. This might cause a misfeed and damage the printer.

- 1 Open the front cover by pushing the front cover release button.

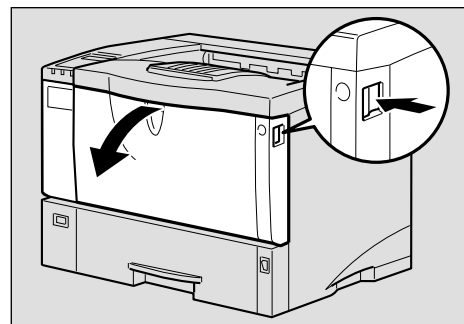

ZKGH120E

- 2** While lifting the front side of the toner cartridge, pull it out of the printer.

**Important**

- Be sure to put the toner cartridge on a stable, flat surface.
- Do not hold the toner cartridge upside down or stand it vertically.

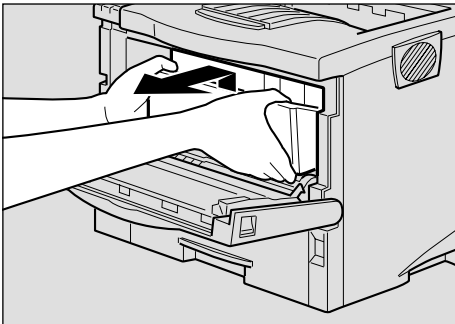

ZKGT110E

- 3** Pull out the misfed paper by holding both sides of paper. Be careful not to get toner dust on your hands or clothes.

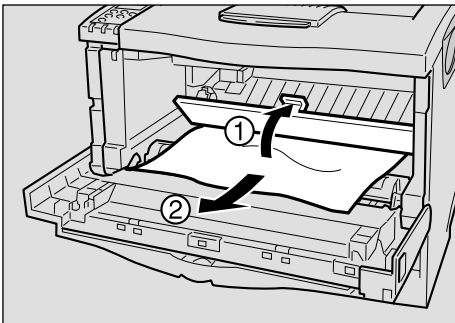

ZKGY520E

- 4** Holding the grips of the toner cartridge, insert it into the printer until it stops.

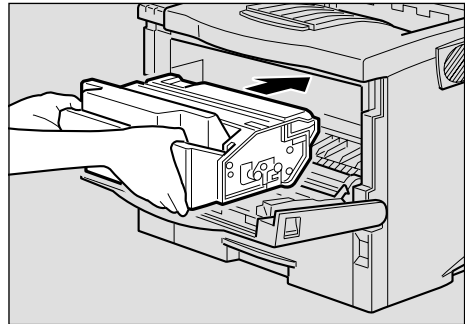

ZKGT120E

- 5** Push down the toner cartridge to settle it in appropriate position.

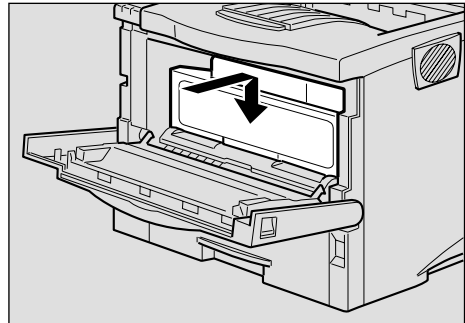

ZKGT140E

- 6** Close the front cover.

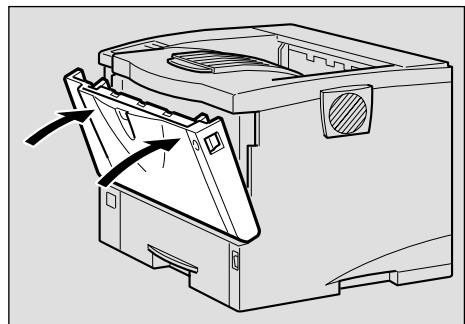

ZKGH130E

**Important**

- If paper is fed from the Bypass Tray, be sure to remove all the paper from the Bypass Tray and close it before opening the front cover.

## When "Remove Misfeed Paper Exit Cover" Appears

**⚠ CAUTION:**

- When removing misfeed paper, do not touch the fusing section because it becomes very hot.
- The fusing unit becomes very hot. When installing the new fusing unit, turn off the printer and wait about an hour. After that, install the new fusing unit. Not waiting for the unit to cool down can result in a burn.

5

**⚠ Important**

- ❑ Forcefully removing misfeed paper may cause paper to tear and leave scraps of paper in the printer. This might cause a misfeed and damage the printer.

- 1** If you installed the 1-bin Shift Sort Tray, slide the upper tray out from it. If you installed the Mailbox, slide the output tray into lower slide out from it.

The following procedures are example of Mailbox.

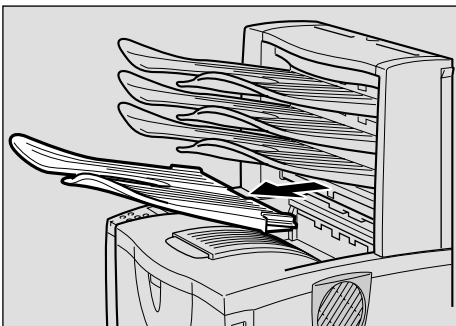

ZKGY371E

- 2** Open the paper exit cover.

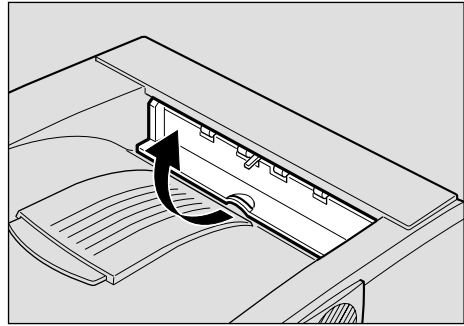

ZKGY391E

- 3** Remove the misfeed paper.

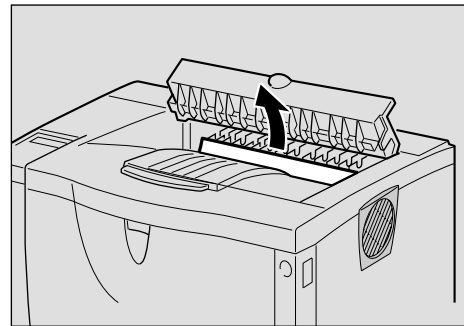

ZKGY380E

- 4** Close the paper exit cover until it clicks.

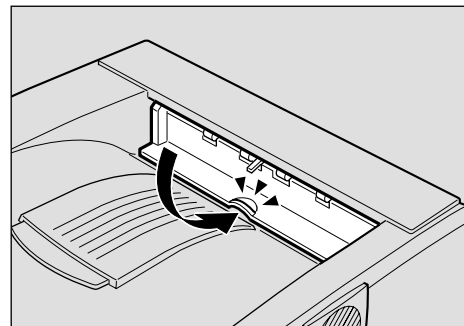

ZKGY400E

**5** If the misfed paper is in the fusing unit, remove it.

**1** Open the rear cover by pushing the two knobs.

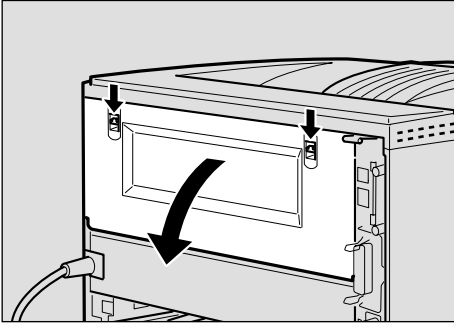

**2** Remove the rear cover in a horizontal direction.

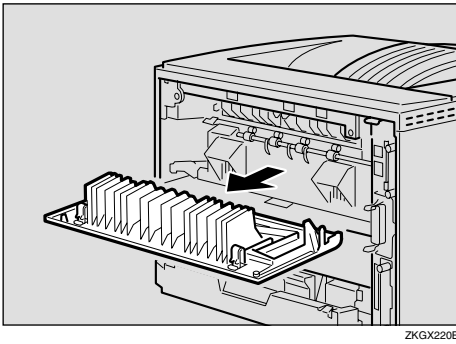

**6** Lift the lock levers of the fusing unit as shown in the illustration.

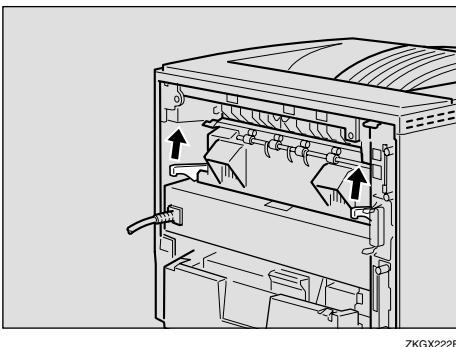

**7** Pull the fusing unit out.

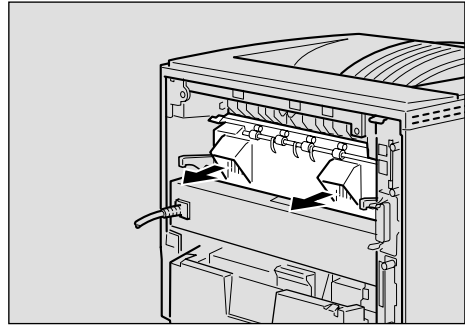

**8** While holding the tab, remove the misfed paper.

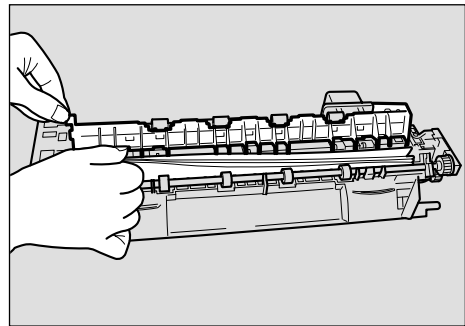

**Important**

❑ Do not touch the metal part of the fusing unit. It becomes very hot. Touching it could result in a burn.

**9** Insert the fusing unit until it stops.

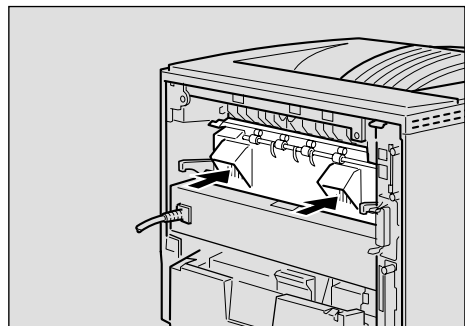

- 10** Push the lock levers of the fusing unit down until it clicks.

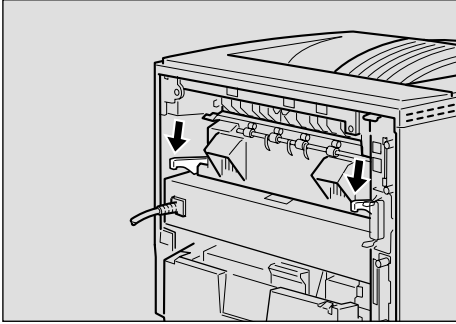

ZKGX225E

- 11** Insert the rear cover to the inside grooves on both sides of the printer in a horizontal direction.

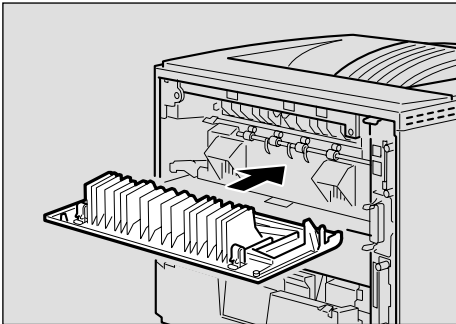

ZKGX221E

- 12** Close the rear cover.

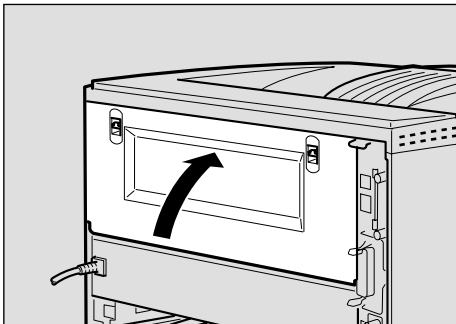

ZKGX211E

## When "Remove Misfeed Duplex Unit" Appears

**⚠ CAUTION:**

- When removing misfed paper, do not touch the fusing section because it becomes very hot.

**⚡ Important**

- ❑ Forcefully removing misfed paper may cause paper to tear and leave scraps of paper in the Duplex Unit. This might cause a misfeed and damage the printer.

- 1** Remove the misfed paper inside of the cover.

- 1** Open the rear cover of the Duplex Unit.

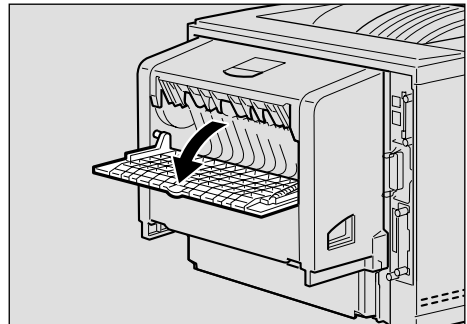

ZKGY310E

- 2** Remove the misfed paper.

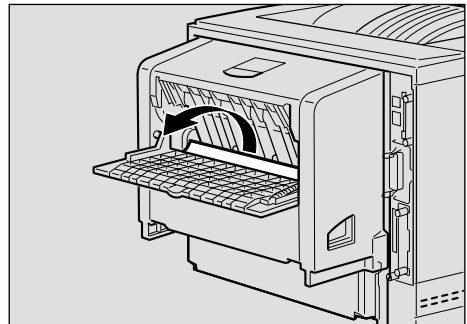

ZKGY320E



- 3** Close the rear cover of the Duplex Unit.

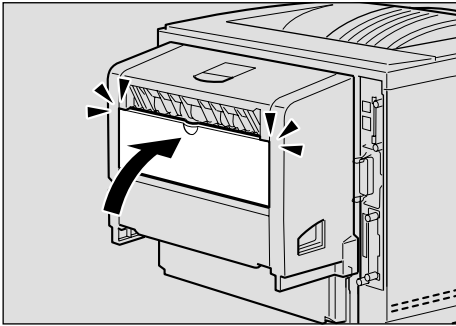

ZKGY330E

- 4** While lifting the lever (1), open the cover of the Duplex Unit (2).

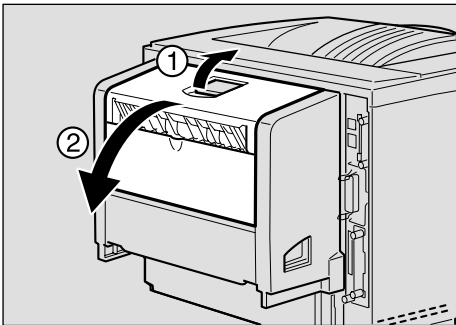

ZKGY340E

- 5** Remove the misfed paper.

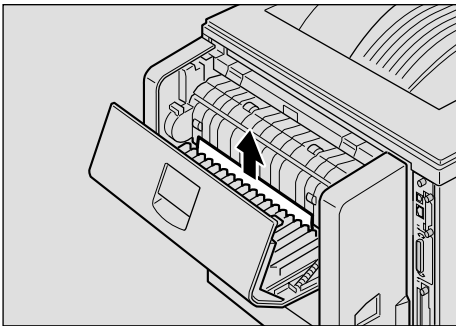

ZKGY350E

- 6** Close the cover of the Duplex Unit.

If the error message appears again, go to step 2.

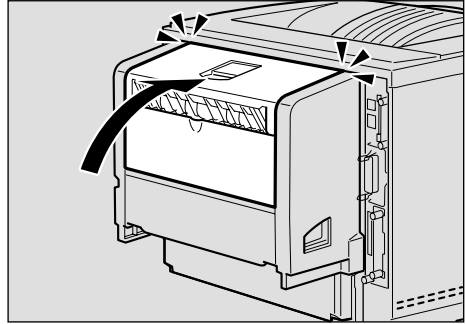

ZKGY360E

- 2** Pull the Duplex Unit out of the printer until it stops, and remove the misfed paper.

- 1** Push down the lever on the right side of the Duplex Unit (1) and pull it out until it stops (2).

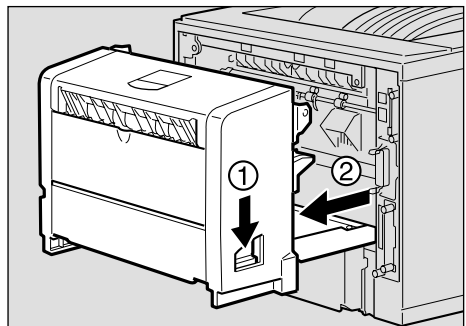

ZKGY320E

- 2 Lift the guide board inside the Duplex Unit, and remove the misfed paper.

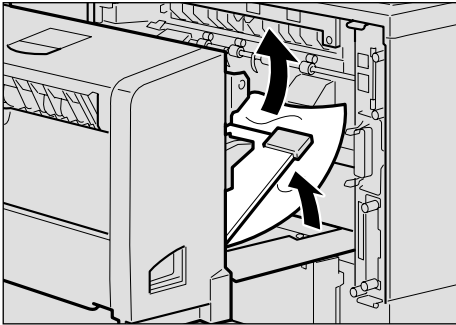

ZKGY440E

**Important**

- When A5 paper misfeeds, you might not be able to remove it by pulling the Duplex Unit out. In this case, pull the paper tray out and remove the paper.

- 3 While aligning the power cord with the groove of the left slide of the Duplex Unit, insert the Duplex Unit into back of the printer aligning the rails inside of the printer until it is connected.

If the error message appears again, the misfed paper might be left in the printer. Confirm that any torn paper scraps are not in the inside of the printer. For more information, see p.102 "When "Remove Misfeed Internal Path/Open Front Cover" Appears".

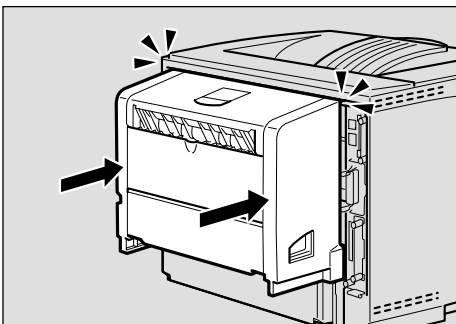

ZKGY240E

## When "Remove Misfeed Mailbox" Appears

**Important**

- Forcefully removing misfed paper may cause paper to tear and leave scraps of paper in the Mailbox. This might cause a misfeed and damage the printer.

- 1 Open the cover of the Mailbox.

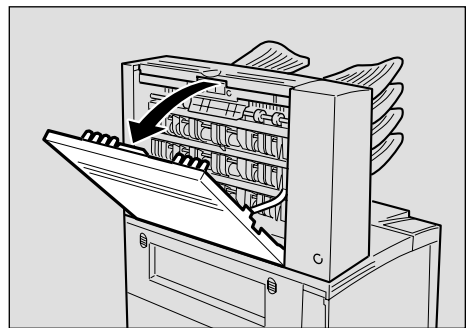

ZKGY460E

- 2 Remove the misfed paper.

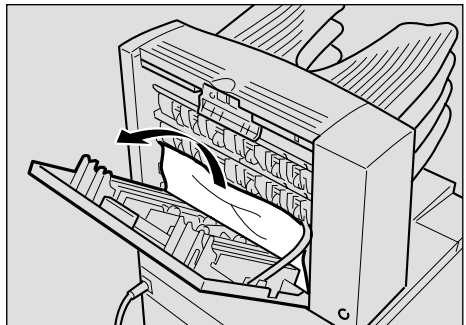

ZKGY470E

- 3 Close the cover of the Mailbox.

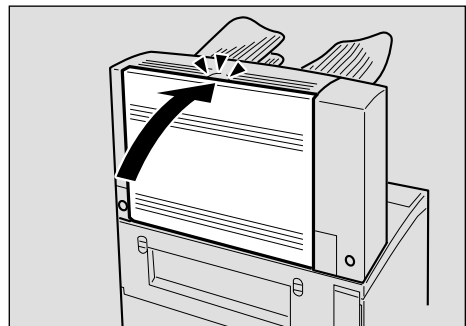

ZKGY480E

## When "Remove Misfeed Upper Tray Unit" Appears

### Important

- Forcefully removing misfed paper may cause paper to tear and leave scraps of paper in the 1-bin Shift Sort Tray. This might cause a mis-feed and damage the printer.

**1** Open the upper tray cover.

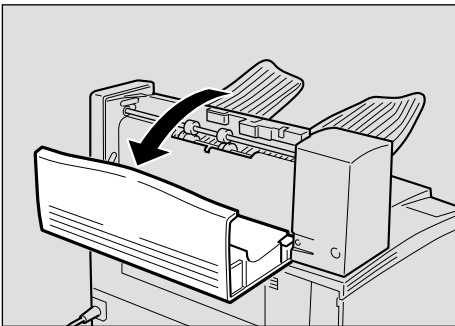

ZKGY490E

**2** Remove the misfed paper.

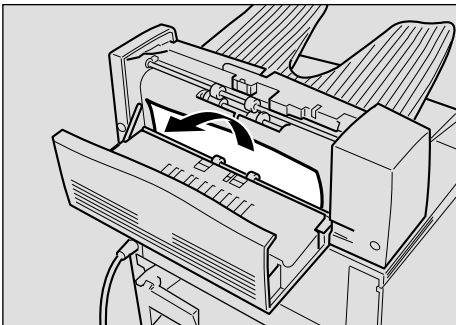

ZKGY500E

**3** Close the upper tray cover.

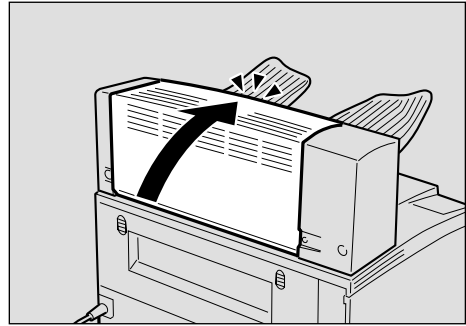

ZKGY510E

# Replacing the Toner Cartridge

**⚠ WARNING:**

- **Do not incinerate spilled toner or used toner. Toner dust might ignite when exposed to an open flame.**
- **Disposal can take place at our authorized dealer or at appropriate collection sites.**
- **If you dispose the used toner cartridges yourself, dispose of them according to your local regulations.**

**⚠ CAUTION:**

- *The inside of the machine could be very hot. Do not touch the parts with a label indicating "⚠" (means hot surface). Touching "⚠" (means hot surface) could result in a burn.*
- *Do not eat or swallow toner.*
- *Keep toner (used or unused) and toner cartridges out of reach of children.*
- *Our products are engineered to meet the highest standards of quality and functionality. When purchasing expendable supplies, we recommend using only those specified by an authorized dealer.*

When "Replace Toner Cartridge" appears on the panel display, the toner is almost empty. Prepare a new toner cartridge. If the image density gets too light, replace the toner cartridge with a new one.

**⚠ Important**

- ❑ Do not expose the toner cartridge to light for a long time. Do not leave the front cover open for a long time. If the toner cartridge is exposed to a light for a long time, the toner cartridge might be damaged and print quality might be reduced.

**📝 Note**

- ❑ Do not stand or place the toner cartridge upside-down.
- ❑ The actual number of printed pages you get from a particular toner cartridge depends on the type and size of paper you are using, the contents of the print images, and printing environment conditions. All this means that a toner cartridge might require replacement sooner than the normal life described on p.204 "Consumables".

**1** Open the front cover by pushing the front cover release button.

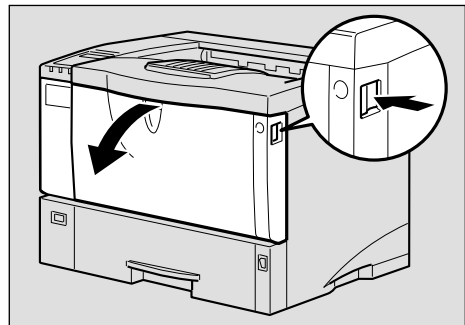

ZKGH120E

- 2** Be sure to put the toner cartridge on a stable, flat surface.

 **Note**

- Do not put the toner cartridge on an unstable or tilted surface.

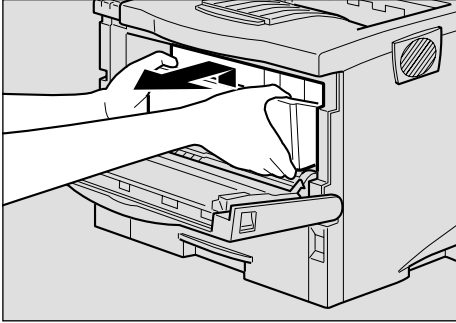

ZKGT110E

- 3** Wipe around the metallic registration roller by turning with a soft damp cloth.



ZKGX461E

 **Important**

- Do not use chemical cleaner or organic solvent such as thinner or benzene.

- 4** Take the new toner cartridge from the box.

- 5** Place the toner cartridge on a flat surface. Pull out the tape inside the unit horizontally while holding the cartridge with one hand as shown in the illustration.

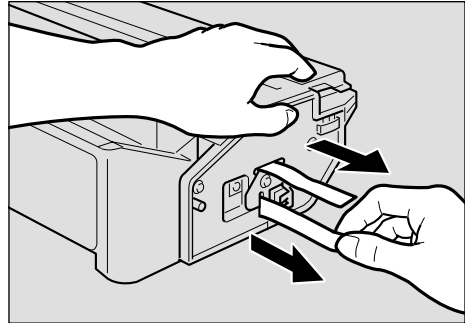

ZKGT151E

 **Note**

- Be sure to remove the tape completely before installing the new toner cartridge, otherwise the printer might be damaged.
- Keep the toner cartridge horizontal when pulling out the toner seal. Pulling out the toner seal with the cartridge upright or tilted can cause printer failure.
- Be careful not to get toner dust on your hands or clothes.
- Do not shake or shock the toner cartridge after pulling out the toner seal to avoid dirt on paper surfaces, toner spillage, or printer failure.

- 6** Holding the grips of the cartridge, insert it into the printer until it stops.

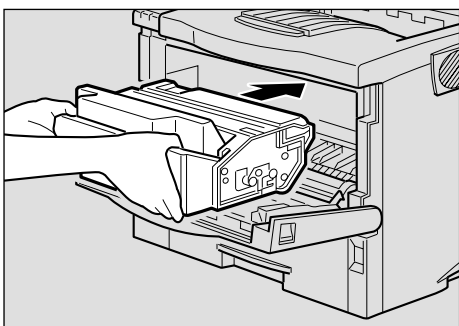

ZKGT120E

- 7** Push down the toner cartridge to settle it in appropriate position.

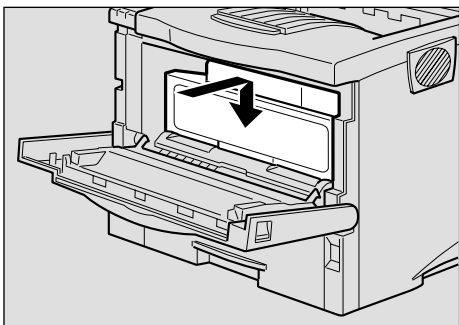

ZKGT140E

- 8** Close the front cover.

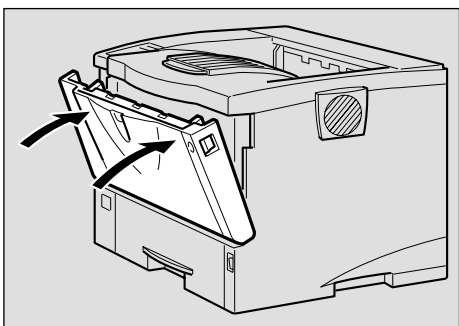

ZKGH130E

**Important**

- ❑ Do not close the front cover with force. If you cannot close the cover easily, pull out the toner cartridge from the printer and insert it again. After that, close the front cover again.

# Cleaning and Adjusting the Printer

## Cleaning the Friction Pad

If the friction pad is dirty, a multi-feed or a misfeed might occur. In this case, clean the pad as follows:

- 1** Lift the paper tray slightly then pull it out until it stops, and while lifting the front side of the tray, pull it out of the printer.

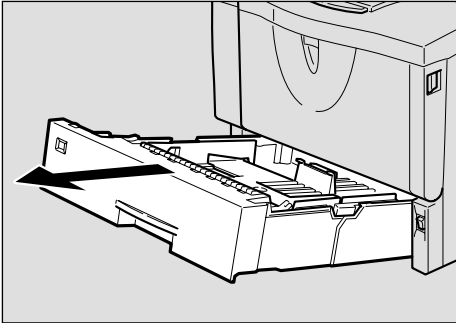

ZKGY140E

- 2** Place the tray on a flat surface. When there is paper in the tray, remove paper.
- 3** Wipe the brown part of the friction pad with a soft damp cloth. After that, wipe it with a dry cloth to remove the water.

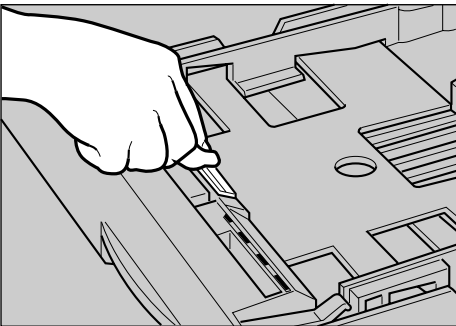

TSY250E

### Important

- Do not use chemical cleaner or organic solvent such as thinner or benzene.

- 4** Load paper into the paper tray with the print side up. Carefully slide the paper tray into the printer until it stops.

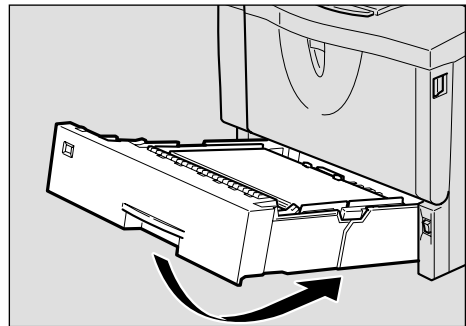

ZKGY150E

### Important

- Do not slide the paper tray in with force. If you do, the front and side guides might move.

### Note

- If misfeeds or multi-feeds of paper occur after cleaning the friction pad, contact your sales or service representative.
- Follow the same procedure to clean the friction pad of the optional Paper Feed Unit and the Envelope Feeder Unit.

## Cleaning the Paper Feed Roller

If the paper feed roller is dirty, a mis-feed might occur. In this case, clean the roller as follows:

### ⚠ CAUTION:

- When lifting the printer, use the grips on both sides of the printer, otherwise the printer might fall and cause personal injury.
- When you move the printer, unplug the power cord from the wall outlet to avoid a fire or an electric shock.
- When you pull out the plug from the socket, grip the plug to avoid damaging the cord and causing a fire or an electric shock.

### ⚠ Important

- ❑ The following are examples of cleaning the paper feed roller on the paper tray.
- ❑ You can clean the paper feed roller on the optional Paper Feed Unit by following the procedures below. The paper feed roller on the optional Paper Feed Unit differs from the one on the paper tray. Confirm the type of paper feed roller you are installing.

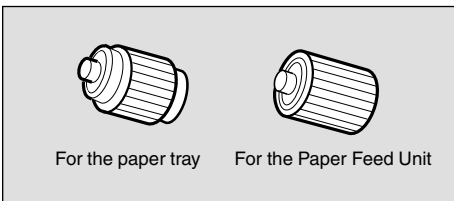

**1** Turn off the power switch.

**2** Pull out the plug from the socket. Remove all the cables from the printer.

**3** Lift the paper tray slightly then pull it out until it stops, and while lifting the front side of the tray, pull it out of the printer.

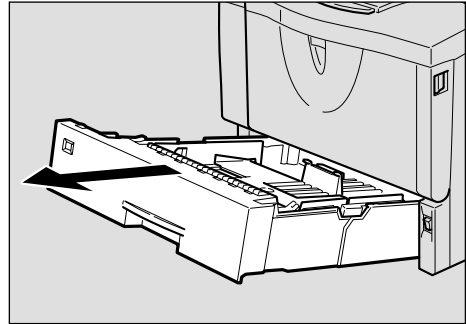

**4** Move the printer to the edge of a stable table or desk.

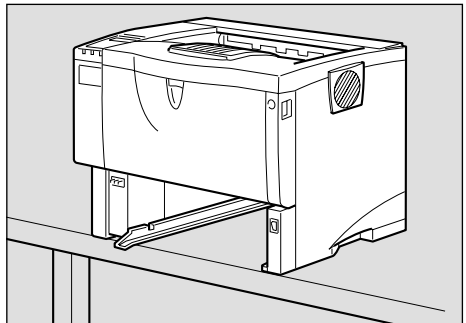

### ⚠ Important

- ❑ Do not put the printer on an unstable or tilted surface.
- ❑ If the printer is equipped with the optional Paper Feed Unit, do not move the printer and unit together as they are not securely attached.
- ❑ When lifting the printer, confirm that the optional Paper Feed Unit is not attached to the printer.



- 5** Slide the green lock lever to the left (①), so that the paper feed roller can be released (②).

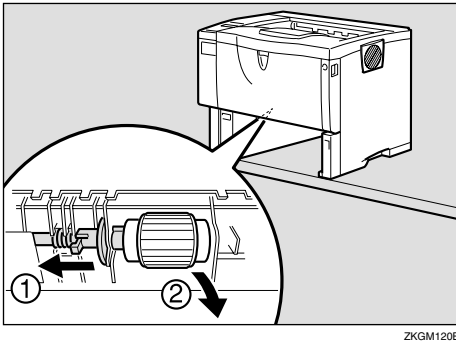

ZKGM120E

- 6** Wipe the rubber part of the roller with a soft damp cloth. After that, wipe it with a dry cloth to remove the water.

**Important**

- Do not use chemical cleaner or organic solvent such as thinner or benzene.

- 7** While sliding the green lock lever to the left (①), set the paper feed roller to its original position (②). After that, return the green lock lever to its original position (③).

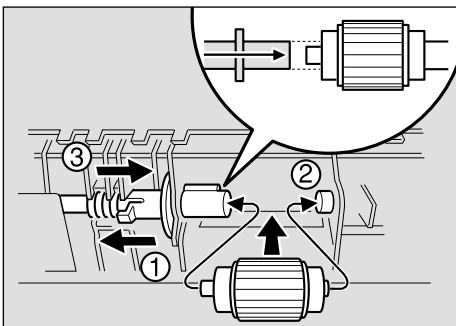

ZKGM130E

**Note**

- Confirm that the green lock lever secures the roller correctly by confirming that the roller rotates smoothly.

- 8** Move the printer to the place where it was placed. Carefully slide the paper tray into the printer until it stops.

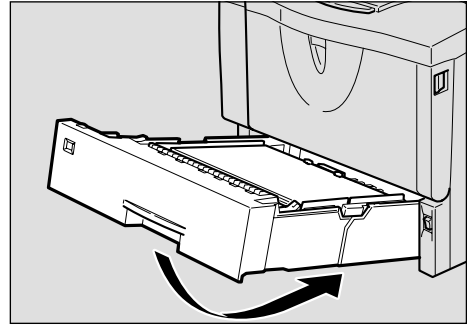

ZKGY150E

**Important**

- Do not slide the paper tray in with force. If you do, the front and side guides might move.

- 9** Insert the plug of the power cord into the wall socket securely. Connect all the cables that were removed in step 2.

- 10** Turn on the power switch.

**Note**

- Follow the same procedure to clean the paper feed roller of the optional Paper Feed Unit.

## Cleaning the Registration Roller

If the registration roller is dirty, a mis-feed might occur. In this case, clean the roller as follows:

**⚠ WARNING:**

- **Be sure to turn off the power switch and wait for about 30 minutes before cleaning the registration roller. Not waiting for the printer to cool down can result in a burn.**

**⚠ CAUTION:**

- *The inside of the machine could be very hot. Do not touch the parts with a label indicating "⚠" (means hot surface). Touching "⚠" (means hot surface) could result in a burn.*

- 1** Turn off the power switch.
- 2** Open the front cover by pushing the front cover release button.

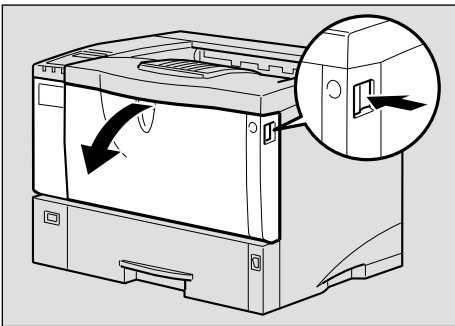

ZKGH120E

- 3** Pull the toner cartridge out of the printer by holding the grips of the cartridge.

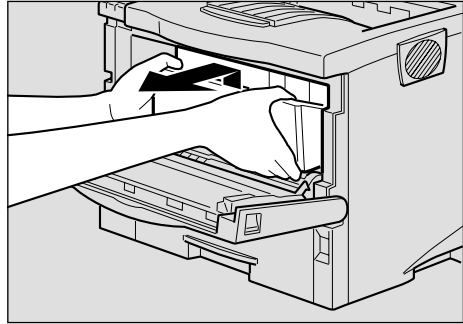

ZKGT110E

**Note**

- Do not hold the toner cartridge upside down or stand it vertically.
- Do not put the toner cartridge on an unstable or tilted surface.

- 4** Wipe around the metallic registration roller by turning with a soft damp cloth.

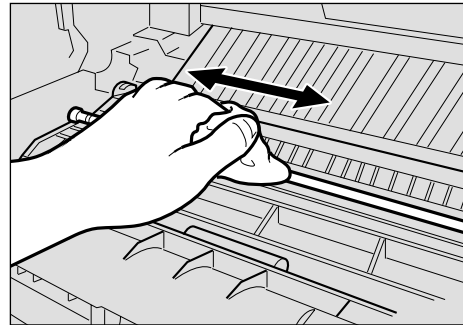

ZKGX461E

**⚠ Important**

- Do not use chemical cleaner or organic solvent such as thinner or benzene.

- 5 Holding the grips of the toner cartridge, insert it into the printer until it stops.

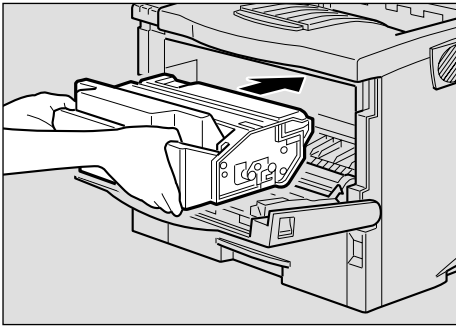

ZKGT120E

- 6 Lower the toner cartridge when it touches the back.

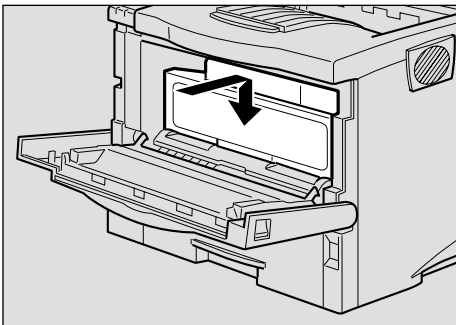

ZKGT140E

- 7 Close the front cover.

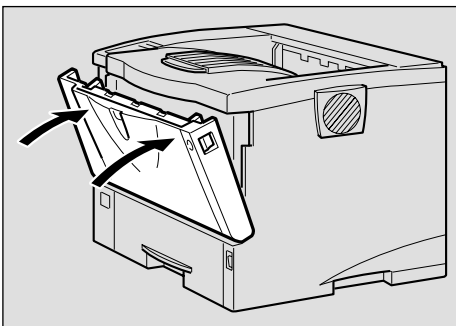

ZKGH130E

**Important**

- ❑ Carefully close the front cover. If you cannot close the cover easily, pull the toner cartridge out of the printer and insert it again. After that, close the front cover again.

- 8 Turn on the power switch.

## Adjusting the Image Density

You can adjust the image density when the print side of the page is a shaded or print image is too light.

**Important**

- ❑ Extreme settings may create print-outs that appear dirty.
- ❑ Image density settings should be made from the application or the printer driver whenever possible.

- 1 Press **[Menu]**.

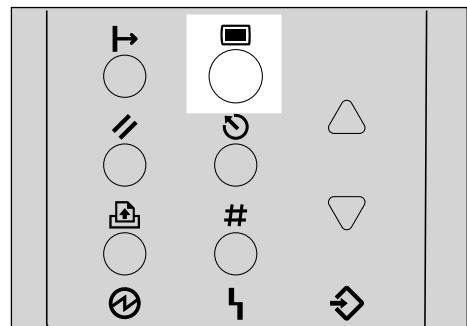

ZKGS020E

"Menu" appears on the panel display.

- 2 Press **[▲]** or **[▼]** to display the "Maintenance" menu, and then press **[Enter #]**.

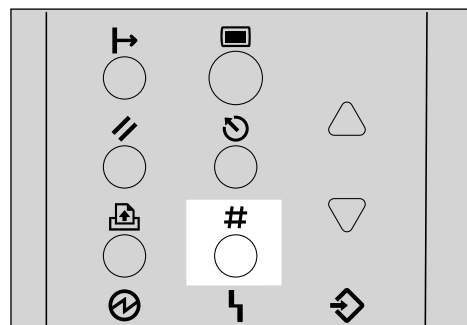

ZKGS021E

The following message appears on the panel display.



**3** Press **[Enter #]**.



**4** Press **[▲]** or **[▼]** to set the image density value.

**Note**

- To maintain a darker image under high volume printing conditions, we highly recommended that you select 3 from the control panel.
- You can adjust the image density in seven steps from -3 to +3. Increasing the value makes the printouts darker and decreasing the value makes the printouts lighter.

**5** Press **[Enter #]**.

**6** Press **[On Line]**.

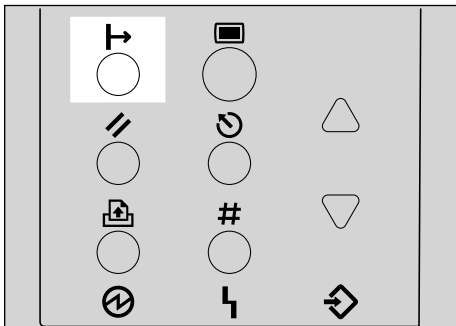

ZKGS022E

"Ready" appears on the panel display.

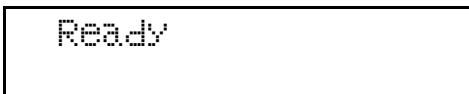

## Adjusting the Registration of the Trays

You can adjust the registration of each tray. The vertical adjustment is used for all trays. Normally, you need not update the registration. But when the optional Paper Feed Unit or the Duplex Unit is installed, updating the registration is useful in some case.

The following procedure describes how to adjust Tray 1. You can use the same procedure to adjust the other tray as well.

**1** Press **[Menu]**.

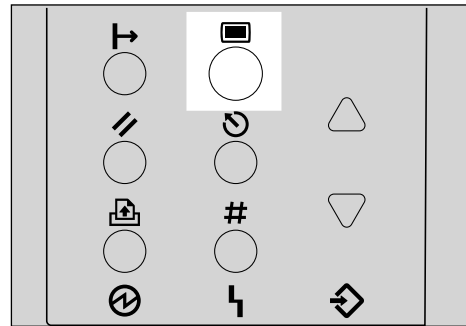

ZKGS020E

"Menu" appears on the panel display.

**2** Press **[▲]** or **[▼]** to display the "Maintenance" menu, and then press **[Enter #]**.

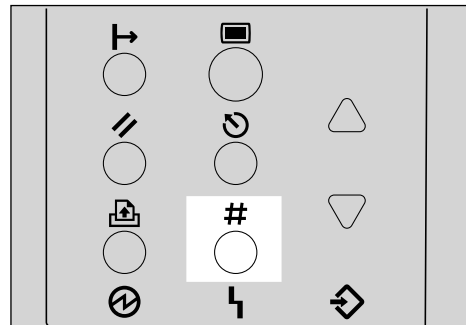

ZKGS021E



- 3** Press **[▲]** or **[▼]** to display "Registration", and then press **[Enter #]**.

The following message appears on the panel display.

```
Registration:
Prt. Test Sheet
```

- 4** Print the test sheet to preview the settings you have made.

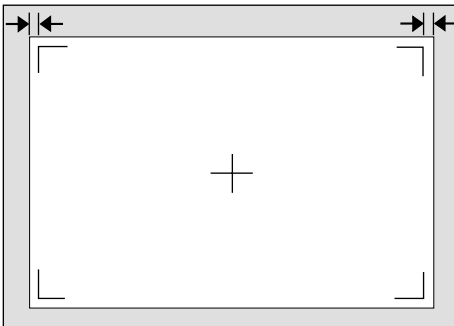

ZKGX480E

- 1** After confirming that "Prt. Test Sheet" is on the panel display, press **[Enter #]**.

The following message appears on the panel display.

```
Prt. Test Sheet
Tray 1
```

- 2** Press **[▲]** or **[▼]** to display the tray you want to adjust, and then press **[Enter #]** to print the test sheet. Wait for a few seconds.

The following message appears on the panel display.

```
Printing...
```

- 5** Adjust the registration by confirming the position of the printed image of the test sheet.

The following is an example of adjusting the margin on the test sheet equally.

- 1** Press **[▲]** or **[▼]** to display "Adjustment", and then press **[Enter #]**.

The following message appears on the panel display.

```
Adjustment:
Horiz.: Tray 1
```

- 2** Press **[▲]** or **[▼]** to display the tray you want to adjust, and then press **[Enter #]**.

The following message appears on the panel display.

```
Horiz.: Tray 1:
(-4.0 +4.0) 0.0
```

- 3** Press **[▲]** or **[▼]** to set the digit of the registration value (mm).

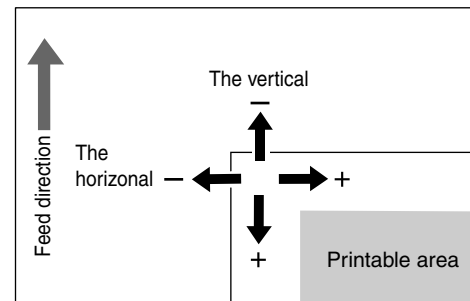

TS3X001N

**Note**

- Increase the value to shift the print area to the positive direction, and decrease to shift to the negative direction.
- Pressing **[▲]** or **[▼]** makes the value increase or decrease by 0.5 mm step.

- 4** Press **[OK]**.

**6** Print the test sheet to check the settings you have made.

**7** Repeat steps **3** and **4** to adjust the registration if necessary.

**8** Press **[On Line]**.

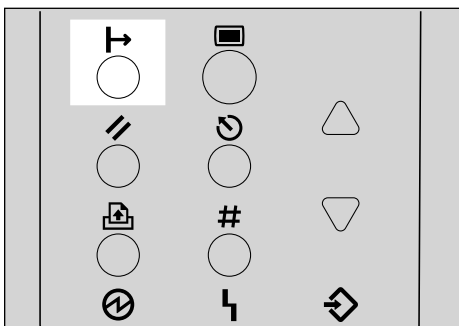

ZKGS022E

5

“Ready” appears on the panel display.



# 6. Making Printer Settings with the Control Panel

## Menu Chart

This section describes how to change the default settings of the printer and provides information on the parameters included in each menu. Some items in the menu appear only when certain options are installed.

| Category               | Function menu                 |
|------------------------|-------------------------------|
| Sample Print *1 ⇒ p.63 | Select Action / Error File(s) |
| Locked Print *1 ⇒ p.68 | Select Action / Error File(s) |
| Paper Input⇒ p.126     | Bypass Size                   |
|                        | Tray Paper Size               |
|                        | Paper Type                    |
|                        | Tray Locking                  |
|                        | Tray Priority                 |
| List/Test Print⇒ p.130 | Config.P/Er.Log               |
|                        | Config. Page                  |
|                        | Error Log                     |
|                        | Menu List                     |
|                        | PS Font List                  |
|                        | PCL Config.Page               |
|                        | PDF Config.Page               |
|                        | Hex Dump                      |
| Maintenance⇒ p.137     | Image Density                 |
|                        | Registration                  |
|                        | Curl Prevention               |
|                        | HDD Format                    |
|                        | WL.LAN Signal *2              |
|                        | WL.LAN Defaults *2            |
|                        | Key Repeat                    |
|                        | Menu Protect *3               |
|                        | Ppr.Size Error *3             |

| Category              | Function menu      |
|-----------------------|--------------------|
| System⇒ p.148         | Prt. Err Report    |
|                       | Auto Continue      |
|                       | Memory Overflow    |
|                       | Copiess            |
|                       | Printer Lang.      |
|                       | Sub Paper Size     |
|                       | Page Size          |
|                       | Edge-Edge Print    |
|                       | Def.Print Lang.    |
|                       | Duplex *4          |
|                       | Output Tray        |
|                       | Job Separation     |
|                       | Energy Saver       |
|                       | Memory Usage       |
|                       | Unit Of Measure    |
|                       | Edge Smoothing     |
|                       | Toner Saving       |
|                       | Spool Printing     |
|                       | Letterhead Mode    |
|                       | RAM Disk *5        |
| Host Interface⇒ p.156 | Notify by E-Mail   |
|                       | E-Mail Date        |
|                       | I/O Buffer         |
|                       | I/O Timeout        |
|                       | Network Setup      |
|                       | IEEE 1394 Setup *6 |
| IEEE 802.11b *7       |                    |
| USB Setting *3        |                    |



| Category        | Function menu   |
|-----------------|-----------------|
| PCL Menu⇒ p.164 | Orientation     |
|                 | Form Lines      |
|                 | Font Source     |
|                 | Font Number     |
|                 | Point Size      |
|                 | Font Pitch      |
|                 | Symbol Set      |
|                 | Courier Font    |
|                 | Ext. A4 Width   |
|                 | Append CR to LF |
|                 | Resolution      |
| PS Menu⇒ p.168  | Data Format     |
|                 | Resolution      |
| PDF Menu⇒ p.171 | PDF: Change PW  |
|                 | Resolution      |
| Language⇒ p.174 |                 |

- \*1 The "Sample Print" menu and the "Locked Print" menu appear only when the optional Hard Disk Drive is installed.
- \*2 The "WL.LAN Signal" and "WL.LAN Defaults" menus appear only when the optional 802.11b Interface Unit is installed.
- \*3 While the printer is **On Line**, press **[Enter #]**, and then press **[Escape]**. Finally, press **[Menu]**. You can access the "Menu Protect", "Ppr.Size Error", and "USB Setting" on the panel display.
- \*4 The "Duplex" menu appears only when the optional Duplex Unit is installed.
- \*5 The "RAM Disk" appears only when the optional hard disk drive is not installed.
- \*6 The "IEEE 1394 Setup" menu appears only when the optional 1394 Interface Unit is installed.
- \*7 The "IEEE 802.11b Setup" menu appears only when the optional 802.11b Interface Unit is installed.

## Accessing the Main Menu

Press **[Menu]**, and "Menu" appears on the panel display.

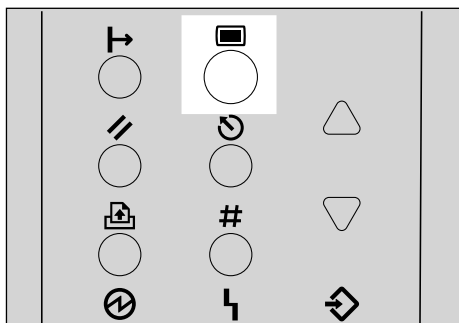

ZKGS020E

This menu shows the following nine items which can be displayed one by one pressing **[▲]** or **[▼]**.

- Sample Print
- Locked Print
- Paper Input
- List/Test Print
- Maintenance
- System
- Host Interface
- PCL Menu
- PS Menu
- PDF Menu
- Language

### Note

- "Sample Print" and "Locked Print" appear only when the optional Hard Disk Drive is installed.
- [▼]**: Press to go to the next page.
- [▲]**: Press to go back to the previous page.

- ❑ After making the printer settings, be sure to return to the previous menu by pressing **[Escape]**.

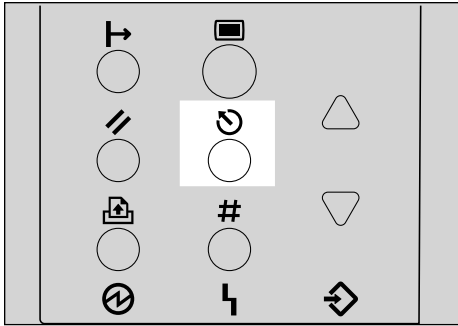

ZKGS024E

- ❑ After making the printer settings, press **[On Line]** to return to the “Ready” condition.

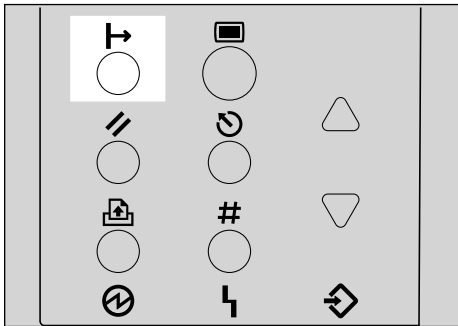

ZKGS022E

- ❑ The revised settings are not canceled even if the power switch is turned off.

## Paper Input Menu

There are five menu items in the “Paper Input” menu.



- Bypass size
- Tray Paper Size
- Paper type
- Tray Locking
- Tray Priority

### Reference

For more information about loading paper in the tray, see p.49 “Loading Paper and Other Media”.

## Paper Input Parameters

| Menu            | Description  |
|-----------------|--|
| Bypass Size     | The paper size for the Bypass Tray.<br>For more information about paper sizes that can be set in the Bypass Tray, see p.37 “Paper and Other Media Supported by This Printer”.  |
| Tray Paper Size | The paper size for each tray.<br>When you select sizes that are not indicated on the paper size dial of Tray 1, Tray 2 or Tray 3, you should set the dial to “✳” and then select the paper size here.<br><br><b>❖ Tray 1</b><br>For more information about paper sizes that can be set in the Tray 1, see p.37 “Paper and Other Media Supported by This Printer”.<br><br><b>❖ Tray 2</b><br>For more information about paper sizes that can be set in the Tray 2, see p.37 “Paper and Other Media Supported by This Printer”.<br><br><b>❖ Tray 3</b><br>For more information about paper sizes that can be set in the Tray 3, see p.37 “Paper and Other Media Supported by This Printer”.<br><br><b> Note</b><br><input type="checkbox"/> Only the installed trays appear on the panel display. |

| Menu          | Description   |
|---------------|---|
| Paper Type    | <p>If you use different kinds of paper, you set the paper type for Tray 1, Tray 2, Tray 3 or Bypass Tray.</p> <p>❖ <b>Tray 1, Tray 2, Tray 3</b><br/>Plain Paper, Recycled Paper, Special Paper, Color Paper, Letterhead, Preprinted</p> <p>❖ <b>Bypass Tray</b><br/>Plain Paper, Recycled Paper, Special Paper, Color Paper, Letterhead, Preprinted, Transparency, Thick Paper</p> <p> <b>Note</b></p> <ul style="list-style-type: none"> <li><input type="checkbox"/> Default : Plain Paper</li> <li><input type="checkbox"/> Only the installed trays appear on the panel display.</li> </ul>   |
| Tray Locking  | <p>If you use different kinds of paper, you can lock a tray to prevent printing on wrong paper such as letterhead or colored paper. When "Auto Select" is selected in the Paper Source selections from the printer driver, the locked tray will not be used.</p> <p>Tray 1, Tray 2, Tray 3, Bypass Tray</p> <p> <b>Note</b></p> <ul style="list-style-type: none"> <li><input type="checkbox"/> Only the installed trays appear on the panel display.</li> <li><input type="checkbox"/> You cannot lock multiple trays.</li> <li><input type="checkbox"/> If you want to use the locked tray, you must select the tray from the printer driver.</li> <li><input type="checkbox"/> When a locked tray is selected from the printer driver, the printer does not search for another tray.</li> </ul> |
| Tray Priority | <p>You can set priority tray for paper feed when "Auto tray Selected" is selected in the Paper Source selections from the printer driver. When printing from DOS, the tray selected here is used when no tray is selected for a print job.</p> <p>Tray 1, Tray 2, Tray 3, Bypass Tray</p> <p> <b>Note</b></p> <ul style="list-style-type: none"> <li><input type="checkbox"/> Default : Tray 1</li> <li><input type="checkbox"/> Only the installed trays appear on the panel display.</li> <li><input type="checkbox"/> It is recommended that you load paper of the size and direction you most frequently use in the tray selected with "Tray Priority".</li> </ul>   |

## Changing the Paper Input Menu

**1** Press [Menu].

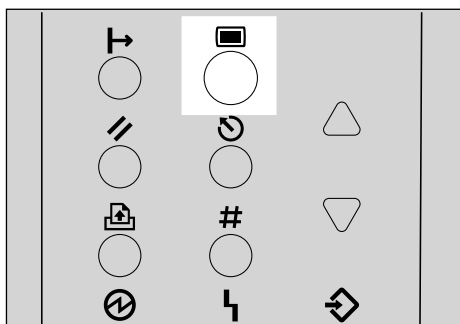

ZKGS020E

“Menu” appears on the panel display.

**2** Press [▲] or [▼] to display the “Paper Input” menu.

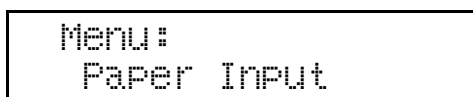

**3** Press [Enter #].

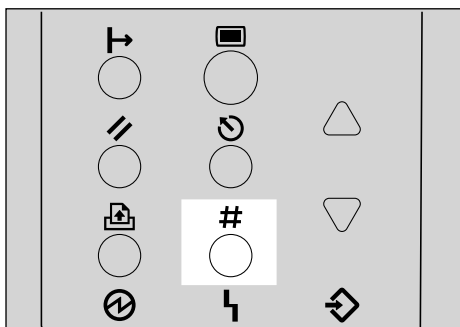

ZKGS021E

**4** Press [▲] or [▼] to display “Tray Priority”.



**5** Press [Enter #].

The following message appears on the panel display.

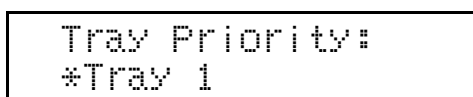

**6** Press **[▲]** or **[▼]** to select the tray type you want to use.

**7** Press **[Enter #]**. Wait for a few seconds.

**8** Press **[On Line]**.

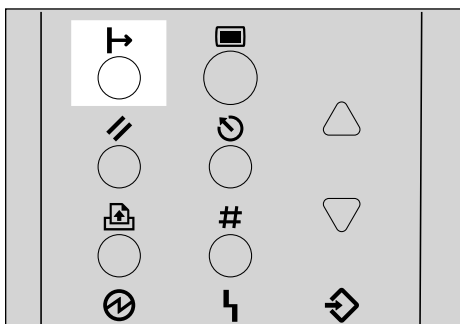

ZKGS022E

“Ready” appears on the panel display.



## List/Test Print Menu

There are eight menu items in the “List/Test Print” menu.

- Config.P/Er.Log
- Config. Page
- Error Log
- Menu List
- PS Font List
- PCL Config.Page
- PDF Config.Page
- Hex Dump

---

### List/Test Print Parameters

---

| Menu            | Description  |
|-----------------|--|
| Config.P/Er.Log | You can print the configuration page and error log.  |
| Config. Page    | You can print the current configuration of the printer. See p.133 “Printing a Configuration Page”.     |
| Error Log       | You can print an error report.   |
| Menu List       | You can print the Menu List which shows the function menus of this printer.                            |
| PS Font List    | You can print the current configuration and installed PS font list of PostScript.                      |
| PCL Config.Page | You can print the current configuration of PCL.  |
| PDF Config.Page | You can print the Adobe® PDF Reference, Memory/HDD status, Printing Configuration, and Resident Fonts. |
| Hex Dump        | You can print the data sent by the computer using the Hex Dump mode.                                   |



## Printing the Configuration Page and Error Log

**1** Press [Menu].

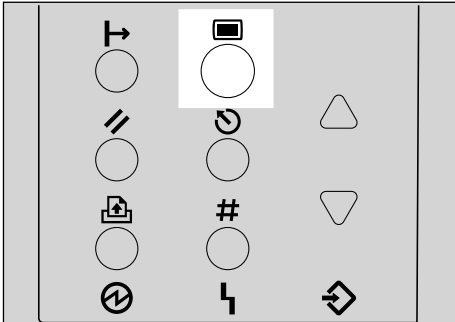

ZKGS020E

“Menu” appears on the panel display.

**2** Press [▼] or [▲] to display the “List/Test Print” menu.

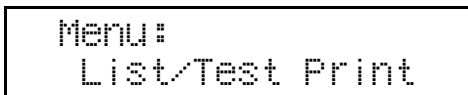

**3** Press [Enter #].

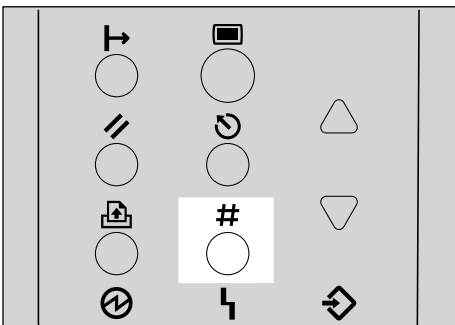

ZKGS021E

The following message appears on the panel display.

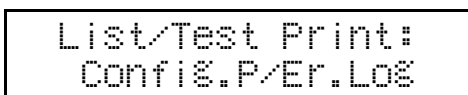

**4** Press **[Enter #]**.

The following message appears on the panel display.

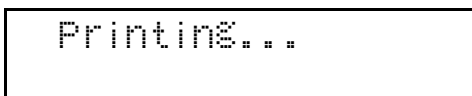

You can print the configuration page and error log.

**Important**

- If you cannot print a configuration page correctly, check for an error message on the panel display. For more information about error messages, see p.75 “Error & Status Messages on the Control Panel”.

**5** Press **[On Line]**.

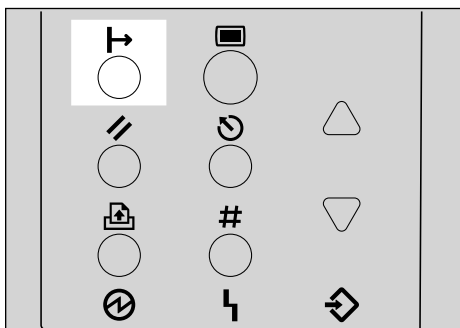

ZKGS022E

“Ready” appears on the panel display.



## Printing a Configuration Page

### Reference

For more information, see p.135 “Interpreting the Configuration Page”.

#### 1 Press [Menu].

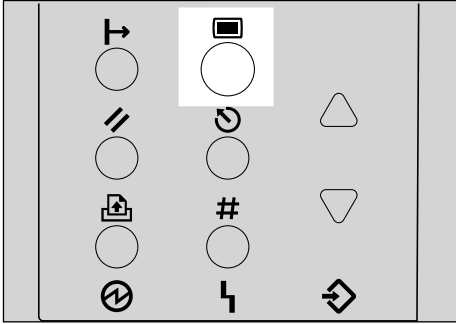

ZKGS020E

“Menu” appears on the panel display.

#### 2 Press [▼] or [▲] to display the “List/Test Print” menu.

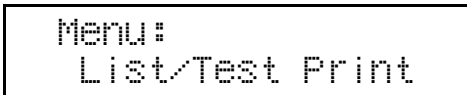

#### 3 Press [Enter #].

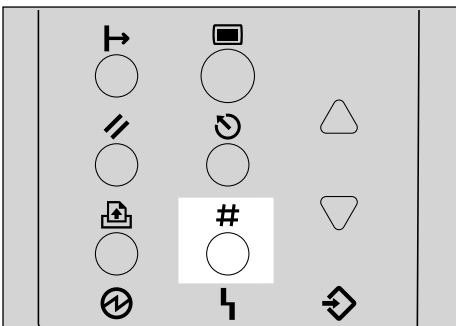

ZKGS021E

The following message appears on the panel display.

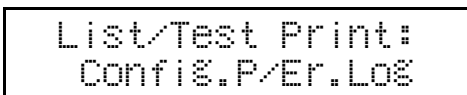

#### 4 Press [▼] or [▲] to display the “Config.Page” menu.

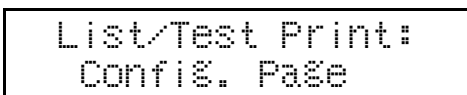

**5** Press **[Enter #]**.

The following message appears on the panel display.

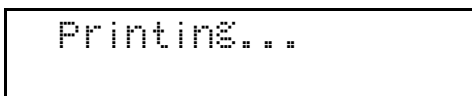

The configuration page will be printed in a short time.

**Important**

- If you cannot print a configuration page correctly, check for an error message on the panel display. For more information about error messages, see p.75 “Error & Status Messages on the Control Panel”.

**6** Press **[On Line]**.

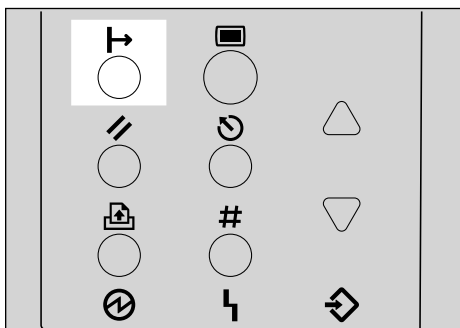

ZKGS022E

“Ready” appears on the panel display.



---

## Interpreting the Configuration Page

---

---

### System Reference

---

#### ❖ Printer ID

Shows the serial number assigned to the board by its manufacturer.

#### ❖ Pages Printed

Shows the total number of pages printed by the printer to date.

#### ❖ Total Memory

Shows the total amount of memory (SDRAM) installed on the printer.

#### ❖ Firmware Version

- Firmware  
Shows the version number of the printer firmware.
- Engine  
Shows the version number of the printer engine.
- NCS  
Shows the version number of the Network interface.

#### ❖ Controller Option

The item(s) appears when the controller option(s) is installed.

#### ❖ Printer Language

Shows the version number of the printer driver language.

#### ❖ Options

Shows the optional trays that you installed.

#### ❖ Consumption Status

Shows the amount of black toner remaining.

---

### Paper Input

---

Shows the settings made under the “Paper Input” menu.

#### Reference

For more information, see p.126 “Paper Input Menu”.

---

### Maintenance

---

Shows the settings made under the “Maintenance” menu.

#### Reference

For more information, see p.137 “Maintenance Menu”.

---

## System

---

Shows the settings made under the “System” menu.

 **Reference**

For more information, see p.148 “System Menu”.

---

---

## PCL Menu

---

Shows the settings you made under the “PCL Menu”.

 **Reference**

For more information, see p.164 “PCL Menu”.

---

---

## PS Menu

---

Shows the settings you made under the “PS Menu”.

 **Reference**

For more information, see p.168 “PS Menu”.

---

---

## PDF Menu

---

Shows the settings you made under the “PDF Menu”.

 **Reference**

For more information, see p.171 “PDF Menu”.

---

---

## Host Interface

---

Shows the settings you made under the “Host Interface” menu.

When DHCP is active on the network, the actual IP Address, Subnet Mask and Gateway Address appear in parentheses on the configuration page.

 **Reference**

For more information about “Host Interface” menu, see p.156 “Host Interface Menu”.

---

---

## Interface Information

---

Shows the interface information.

---

---

## Error Log

---

Shows the log of printer errors.

---

# Maintenance Menu

There are nine menu items in the “Maintenance” menu.









- Image Density
- Registration
- Curl Prevention
- HDD Format
- WL.LAN Signal
- WL.LAN Defaults
- Key Repeat
- Menu Protect
- Ppr.Size Error

## Note



- “HDD Format” appears only when the optional Hard Disk Drive is installed. For more information, see “*Hard Disk Drive Type 2600*” in the Setup Guide.

## Maintenance Menu Parameters

| Menu          | Description  |
|---------------|--|
| Image Density | You can select the print image density.<br>-3 to 3<br> <b>Reference</b><br>For more information, see p.117 “Adjusting the Image Density”. |

| Menu             | Description   |
|------------------|---|
| Registration     | <p>❖ <b>Prt. Test Sheet</b><br/>                     You can print the registration test sheet.<br/>                     Tray 1, Tray 2, Tray 3, Bypass Tray, Duplex backside</p> <p> <b>Note</b></p> <ul style="list-style-type: none"> <li><input type="checkbox"/> Default : Tray 1</li> <li><input type="checkbox"/> Only the installed trays appear on the panel display.</li> </ul> <p>❖ <b>Adjustment</b><br/>                     You can select the start position for printing on a page.<br/>                     Horiz.: Tray 1, Horiz.: Tray 2, Horiz.: Tray 3, Horiz.: Bypass,<br/>                     Horiz.: Dup.Back, Vert.: All Trays, Vert.: Dup.Back<br/>                     -4 to 4</p> <p> <b>Note</b></p> <ul style="list-style-type: none"> <li><input type="checkbox"/> Default : Horiz.: Tray 1</li> <li><input type="checkbox"/> The registration value is not a default.</li> <li><input type="checkbox"/> Only the installed trays appear on the panel display.</li> </ul> <p> <b>Reference</b><br/>                     For more information, see p.118 “Adjusting the Registration of the Trays”.</p> |
| Curl Prevention  | <p>You can control the fuser temperature to prevent paper from curling.</p> <p> <b>Note</b></p> <ul style="list-style-type: none"> <li><input type="checkbox"/> Default: Off</li> <li><input type="checkbox"/> Use this mode only when paper misfeed occurs frequently during duplex printing.</li> </ul>  |
| HDD Format       | <p>After installing the Hard Disk Drive, format it.</p> <p> <b>Note</b></p> <ul style="list-style-type: none"> <li><input type="checkbox"/> This menu appears only when the optional Hard Disk Drive is installed.</li> </ul> <p> <b>Reference</b><br/>                     For more information about formatting the Hard Disk Drive, see p.142 “Formatting Hard Disk Drive Type 2600”.</p>  |
| WL. LAN Signal   | <p> <b>Reference</b><br/>                     For more information about displaying the signal strength, see p.143 “Displaying the Signal Strength”.</p>   |
| WL. LAN Defaults | <p>You can reset the wireless LAN settings to the default.</p>  |
| Key Repeat       | <p>You can scroll through the menu by holding this key down.</p> <p> <b>Note</b></p> <ul style="list-style-type: none"> <li><input type="checkbox"/> Default: On</li> </ul>  |



| Menu                         | Description   |
|------------------------------|---|
| Menu Protect <sup>*1</sup>   | <p>This procedure lets you protect menu settings against accidental changes. It makes it impossible to change the menu settings you make with the normal procedure unless you perform the required key operation. In a network environment, protecting settings restricts who can change menu settings to network administrators.</p> <ul style="list-style-type: none"> <li>• Level 1</li> <li>• Level 2</li> <li>• Off</li> </ul> <p> <b>Note</b></p> <ul style="list-style-type: none"> <li><input type="checkbox"/> Default: Off</li> <li><input type="checkbox"/> While the printer is On Line, press the <b>[Enter #]</b> key, and then press the <b>[Escape]</b> key, finally press the <b>[Menu]</b> key. You can access the "Menu Protect" menu on the panel display.</li> <li><input type="checkbox"/> You can protect the "Maintenance", "System", "Host Interface" and "Language" menu on Level 1.</li> <li><input type="checkbox"/> You can protect the "Paper Input", "Maintenance", "System", "Host Interface" and "Language" menu on Level 2.</li> </ul> |
| Ppr.Size Error <sup>*1</sup> | <p>You can select whether to have an error report printed when the paper size setting for the tray differs from the actual size of the paper in the tray. You can also select whether to have an error message displayed when feeding paper from the tray.</p> <p> <b>Note</b></p> <ul style="list-style-type: none"> <li><input type="checkbox"/> Default: Detect</li> <li><input type="checkbox"/> When it is "Detect", it prints with the paper size that was set when the error message appeared.</li> </ul>   |

<sup>\*1</sup> While the printer is Online, press **[Enter #]**, and then press **[Escape]**. Finally, press **[Menu]**. You can access the "Menu Protect" and "Ppr. Size Error" menu on the panel display.

## Changing the Maintenance Menu

### Setting and canceling the menu protection

Explains the method of setting and canceling menu protection.

#### Locking the panel with Menu Protect

- 1** Check if the On Line indicator is on. If not, press **[On Line]** to enter the "Ready" condition.
- 2** Press **[Enter #]**, then **[Escape]**, and then **[Menu]**.

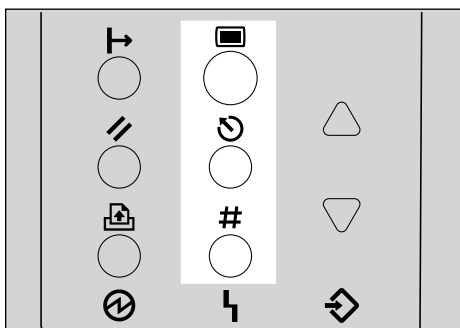

"Menu" appears on the panel display.

- 3** Press **[▲]** or **[▼]** to display the "Maintenance" menu, and then press **[Enter #]**.

The following message appears on the panel display.

```
Maintenance:
Image Density
```

- 4** Press **[▲]** or **[▼]** to display "Menu Protect".

```
Maintenance:
Menu Protect
```

- 5** Press **[Enter #]**.

The following message appears on the panel display.

```
Menu Protect:
*Off
```

**6** Press **[▲]** or **[▼]** to select the levels desired, and then press **[Enter #]**. Wait for a few seconds.

**7** Press **[On Line]**.

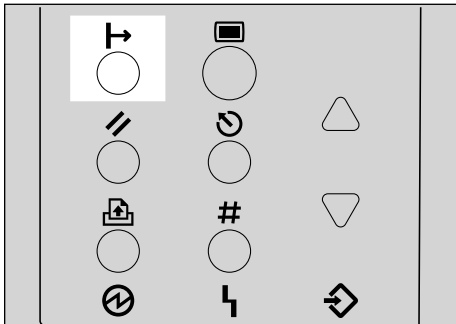

ZKGS022E

"Ready" appears on the panel display.



## Canceling the protection

6

**1** Check if the On Line indicator is on. If not, press **[On Line]** to enter the "Ready" condition.

**2** Press **[Enter #]**, then **[Escape]**, and then **[Menu]**.

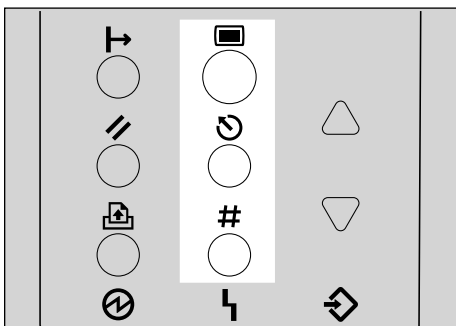

ZKGS025E

"Menu" appears on the panel display.

**3** Press **[▲]** or **[▼]** to display "Maintenance" menu, and then press **[Enter #]**. The following message appears on the panel display.



- 4** Press **[▲]** or **[▼]** to display “Menu Protect”, and then press **[Enter #]**.
- 5** Press **[▲]** or **[▼]** to display “Off”, and then press **[Enter #]**. Wait for a few seconds.
- 6** Press **[On Line]**.  
“Ready” appears on the panel display.

---

### Formatting Hard Disk Drive Type 2600

---

If you are formatting the Hard Disk Drive for the first time, follow the procedures below using the control panel.

- 1** Press **[Menu]**.  
“Menu” appears on the panel display.
- 2** Press **[▲]** or **[▼]** to display “Maintenance” menu.

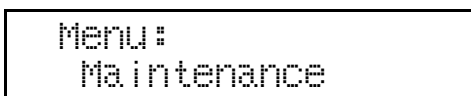

```
Menu:
Maintenance
```

- 3** Press **[Enter #]**.  
The following message appears on the panel display.

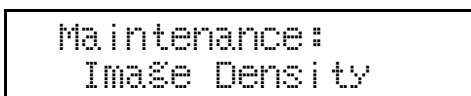

```
Maintenance:
Image Density
```

- 4** Press **[▲]** or **[▼]** to display “HDD Format”.

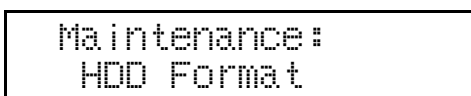

```
Maintenance:
HDD Format
```

- 5** Press **[Enter #]**.  
The following message appears on the panel display.

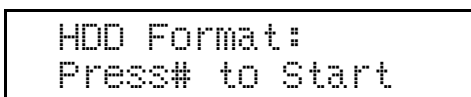

```
HDD Format:
Press# to Start
```

**6** Press **[Enter #]**.**Important**

- Do not turn off the printer while formatting the Hard Disk Drive. Turning off the printer while formatting the Hard Disk Drive can damage the Hard Disk Drive.

If you successfully format the Hard Disk Drive, the following message appears on the panel display.

```
Completed
Restart Printer
```

**7** Turn off the power switch, and then turn it back on.**Displaying the Signal Strength**

If you need to check the IEEE 802.11b (Wireless LAN) signal, select "WL.LAN Signal" in the "Maintenance" menu.

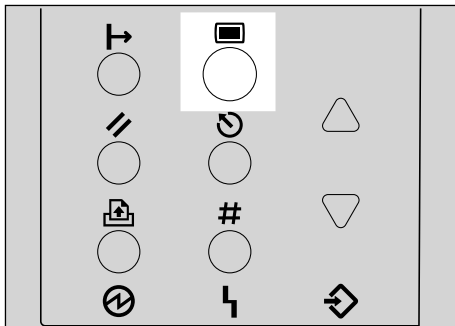
**1** Press **[Menu]**.

ZKGS020E

"Menu" appears on the panel display.

**2** Press **[▼]** or **[▲]** to display the "Maintenance" menu.

```
Menu:
Maintenance
```

**3** Press **[Enter #]**.

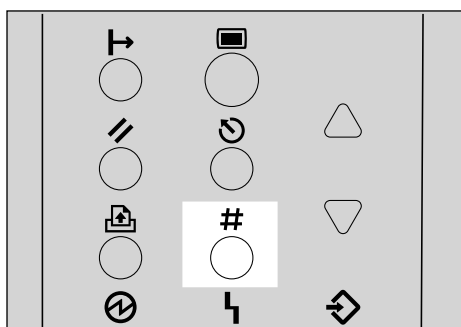

ZKGS021E

The following message appears on the panel display.

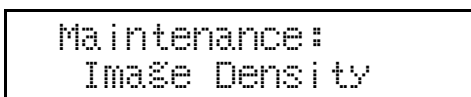

**4** Press **[▼]** or **[▲]** to display "WL.LAN Signal".

6

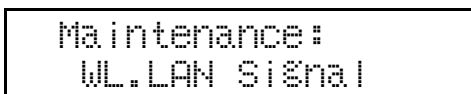

**5** Press **[Enter #]**.

One of the following messages appears on the panel display.

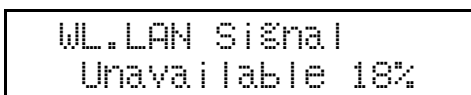
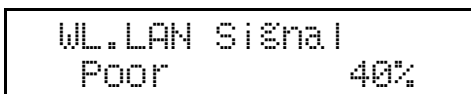
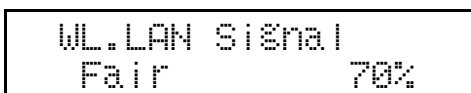
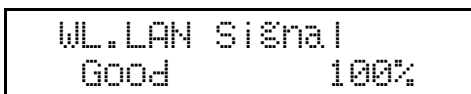

**Note**

- If "WL.LAN Signal" is not displayed, "IEEE 802.11b" has not been selected for "LAN Type" in "Network Setup" of the Host Interface menu. Select "IEEE 802.11b" for "LAN Type", and then check the "WL.LAN Signal" in the Maintenance menu again.
- If "Ad hoc" in "Comm. Mode" of "IEEE 802.11b" in the Host Interface menu is selected, you cannot check the signal. Select "Infrastructure" and then check it again.

- Every time you press **[Enter #]**, the signal is updated.
- The signal is indicated as "Good" if the signal strength is 86-100%, "Fair" if the strength is 61-85%, "Poor" if the strength is 31-60%, and "Unavailable" if the strength is 0-30%. If the signal is unstable or unavailable, remove obstacles or move the printer to a place where the signal can be received.
- Using wireless devices or microwave sources near the printer might affect the signal.

**6** Press **[Escape]**.

**7** Press **[On Line]**.

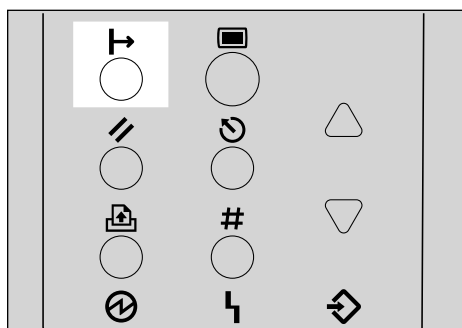

ZKGS022E

"Ready" appears on the panel display.



## Resetting the IEEE 802.11b (Wireless LAN) Settings

If you need to reset the wireless LAN setting, select "WL.LAN Defaults" in the Maintenance menu.

### Note

- The four items that can be reset in "IEEE 802.11b" of the Host Interface menu are "Comm.Mode", "Channel", "Trans. Speed", and "WEP Settings". Other items that can be reset are the SSID settings, the WEP key settings, and the wireless LAN settings that can be made with telnet.

**1** Press **[Menu]**.

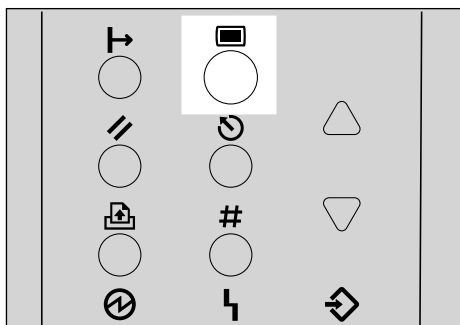

ZKGS020E

"Menu" appears on the panel display.

**2** Press **[▼]** or **[▲]** to display the "Maintenance" menu.

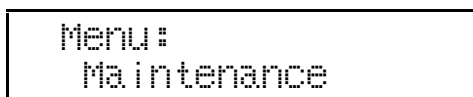

**3** Press **[Enter #]**.

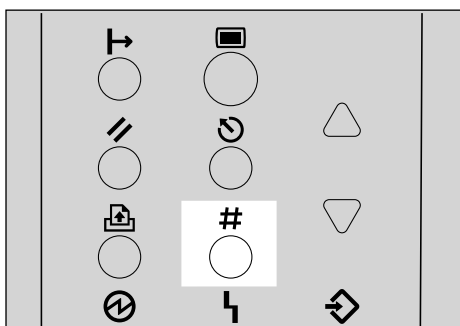

ZKGS021E

The following message appears on the panel display.

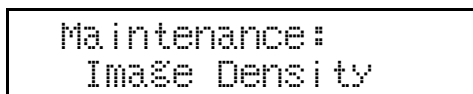

**4** Press **[▼]** or **[▲]** to display "WL.LAN Defaults".



**5** Press **[Enter #]**.

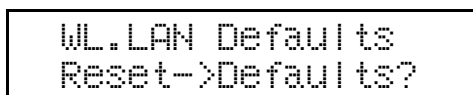



**6** Press **[Enter #]**.

The following message appears on the panel display.

```
Defaults reset  
Press # to exit
```

**7** Press **[Enter #]**.

The following message appears on the panel display.

```
Setting change  
in process
```

The wireless LAN setting value is reset.

“Ready” appears on the panel display.

```
Ready
```

## System Menu

There are 22 menu items in the “System” menu.

- Prt. Err Report
- Auto Continue
- Memory Overflow
- Copies
- Printer Lang.
- Sub Paper Size
- Page Size
- Edge-Edge Print
- Def.Print Lang.
- Duplex
- Output Tray
- Job Separation
- Energy Saver
- Memory Usage
- Unit Of Measure
- Edge Smoothing
- Toner Saving
- Spool Printing
- Letterhead Mode
- RAM Disk
- Nortify by E-Mail
- E-Mail Date





6





---





### System Parameters





---





| Menu            | Description   |
|-----------------|---|
| Prt. Err Report | <p>You can select whether or not to have an error report printed when a printer error or memory error occurs.</p> <ul style="list-style-type: none"> <li>• On</li> <li>• Off</li> </ul> <p> <b>Note</b></p> <p><input type="checkbox"/> Default: Off</p> |

| Menu            | Description   |
|-----------------|---|
| Auto Continue   | <p>You can set whether Auto Continue is enabled. When it is on, printing continues after a system error occurs.</p> <ul style="list-style-type: none"> <li>• Off</li> <li>• 0 minutes</li> <li>• 1 minute</li> <li>• 5 minutes</li> <li>• 10 minutes</li> <li>• 15 minutes</li> </ul> <p> <b>Note</b></p> <ul style="list-style-type: none"> <li><input type="checkbox"/> Default: Off</li> <li><input type="checkbox"/> When it is on and certain types of error occur, the current job might be canceled, and the next job started automatically.</li> </ul> |
| Memory Overflow | <p>You can select whether the memory overflow error report is printed when the data is too large and cannot be processed.</p> <ul style="list-style-type: none"> <li>• Not Print</li> <li>• Error List</li> </ul> <p> <b>Note</b></p> <ul style="list-style-type: none"> <li><input type="checkbox"/> Default: Not Print</li> </ul>  |
| Copies          | <p>You can specify how many pages to print.</p> <p>This setting is disabled if the number of pages to print is already specified with the printer driver or a command.</p> <ul style="list-style-type: none"> <li>• 1-999</li> </ul>  |
| Printer Lang.   | <p>You can specify the printer language.</p> <ul style="list-style-type: none"> <li>• Auto Detect</li> <li>• PCL</li> <li>• PS</li> <li>• PDF</li> <li>• XPDL_0</li> <li>• XPDL_1</li> </ul> <p> <b>Note</b></p> <ul style="list-style-type: none"> <li><input type="checkbox"/> Default: Auto Detect</li> </ul>   |
| Sub Paper Size  | <p>You can select whether the printer automatically selects the paper tray containing paper of the specified size.</p> <ul style="list-style-type: none"> <li>• Off</li> <li>• Auto</li> </ul> <p> <b>Note</b></p> <ul style="list-style-type: none"> <li><input type="checkbox"/> Default: Off</li> </ul>   |

| Menu            | Description   |
|-----------------|---|
| Page Size       | <p>You can specify the default paper size.</p> <p>11 x 17, 8 1/2 x 14, 8 1/2 x 11, 5 1/2 x 8 1/2, 7 1/4 x 10 1/2, 8 x 13, 8 1/2 x 13, 8 1/4 x 13, A3 (297 x 420), B4 JIS (257 x 364), A4 (210 x 297), B5 JIS (182 x 257), A5 (148 x 210), A6 (105 x 148), 8K (267 x 390), 16K (195 x 267), 4 1/8 x 9 1/2, 3 7/8 x 7 1/2, C5 Env (162 x 229), C6 Env (114 x 162), DL Env (110 x 220), Custom Size</p> <p> <b>Note</b></p> <ul style="list-style-type: none"> <li><input type="checkbox"/> Default: A4 (210 x 297)</li> <li><input type="checkbox"/> The value set for page size is applied when the paper size is not specified in the print data.</li> </ul> |
| Edge-Edge Print | <p>You can print on the complete area of an A4 sheet leaving no border on any edge.</p> <p> <b>Note</b></p> <ul style="list-style-type: none"> <li><input type="checkbox"/> Default: Off</li> </ul>  |
| Def.Print Lang. | <p>You can specify the default printer language.</p> <ul style="list-style-type: none"> <li>• PCL</li> <li>• PS</li> <li>• PDF</li> <li>• XPDL_0</li> <li>• XPDL_1</li> </ul> <p> <b>Note</b></p> <ul style="list-style-type: none"> <li><input type="checkbox"/> Default: PCL</li> </ul>   |
| Duplex          | <p>You can select whether you want to print on both sides of each page.</p> <ul style="list-style-type: none"> <li>• Off</li> <li>• Short Edge Bind</li> <li>• Long Edge Bind</li> </ul> <p> <b>Note</b></p> <ul style="list-style-type: none"> <li><input type="checkbox"/> Default: Off</li> <li><input type="checkbox"/> This menu appears only when the optional Duplex Unit is installed.</li> </ul>  |
| Output Tray     | <p>You can select the default output tray. When you select "Auto Tray Sw.", the printer automatically changes to another output tray if an output tray becomes full. This function is available only when the Mailbox or the 1-bin Shift Sort Tray is installed.</p> <p>Standard Tray, Mailbox Tray 1, Mailbox Tray 2, Mailbox Tray 3, Mailbox Tray 4, Upper Tray, Auto Tray Sw.</p> <p> <b>Note</b></p> <ul style="list-style-type: none"> <li><input type="checkbox"/> Default: Standard Tray</li> <li><input type="checkbox"/> Only the installed trays appear on the panel display.</li> </ul>   |

| Menu            | Description   |
|-----------------|---|
| Job Separation  | <p>You can enable Job Separation.</p> <ul style="list-style-type: none"> <li>• On</li> <li>• Off</li> </ul> <p> <b>Note</b></p> <ul style="list-style-type: none"> <li><input type="checkbox"/> Default: Off</li> <li><input type="checkbox"/> This menu appears only when the optional 1-bin Shift Sort Tray is installed.</li> </ul>   |
| Energy Saver    | <p>You can set how many minutes the printer waits before switching to Energy Saver mode. Energy Saver mode reduces electric power consumption.</p> <p>On, Off</p> <p>1 minute, 5 minutes, 15 minutes, 30 minutes, 45 minutes, 60 minutes</p> <p> <b>Note</b></p> <ul style="list-style-type: none"> <li><input type="checkbox"/> Default: On</li> <li><input type="checkbox"/> Default: 30 minutes</li> <li><input type="checkbox"/> If there is an error with the printer, the printer will not switch to Energy Saver mode.</li> <li><input type="checkbox"/> When the printer switches to Energy Saver mode, the <b>Power</b> indicator turns off while the <b>On Line</b> indicator stays on.</li> </ul> |
| Memory Usage    | <p>You can select memory to be used from "Font Priority" or "Frame Priority" according to the paper size, resolution or printer language.</p> <ul style="list-style-type: none"> <li>• Font Priority<br/>This setting uses memory for registering fonts.</li> <li>• Frame Priority<br/>This setting uses memory for high speed printing.</li> </ul> <p> <b>Note</b></p> <ul style="list-style-type: none"> <li><input type="checkbox"/> Default: Frame Priority</li> </ul> <p> <b>Reference</b></p> <p>For more information, see p.190 "Memory Capacity and Paper Size".</p>  |
| Unit Of Measure | <p>You can select "mm" or "inch" for the custom paper sizes.</p>  |

| Menu            | Description  |
|-----------------|--|
| Edge Smoothing  | <p>You can set whether Edge Smoothing is enabled. When it is on, jagged lines appear more smoothly. Set it to off when the print image contains fine gradation in tone.</p> <ul style="list-style-type: none"> <li>• On</li> <li>• Off</li> </ul> <p> <b>Note</b></p> <ul style="list-style-type: none"> <li><input type="checkbox"/> Default: On</li> <li><input type="checkbox"/> If "Toner Saving" is "On", "Edge Smoothing" is ignored even if it is "On".</li> </ul>   |
| Toner Saving    | <p>You can select whether or not Toner Saving is enabled.</p> <ul style="list-style-type: none"> <li>• On</li> <li>• Off</li> </ul> <p> <b>Note</b></p> <ul style="list-style-type: none"> <li><input type="checkbox"/> Default: Off</li> <li><input type="checkbox"/> If "Toner Saving" is "On", "Edge Smoothing" is ignored even if it is "On".</li> </ul>  |
| Spool Printing  | <p>You can select whether all of the print data is spooled to the Hard Disk Drive before printing.</p> <ul style="list-style-type: none"> <li>• On</li> <li>• Off</li> </ul> <p> <b>Note</b></p> <ul style="list-style-type: none"> <li><input type="checkbox"/> Default: Off</li> <li><input type="checkbox"/> Spooling stores the print job sent by a computer temporarily in the printer, transfers the print job, and then prints it.</li> <li><input type="checkbox"/> This menu appears only when the optional Hard Disk Drive is installed.</li> </ul>  |
| Letterhead Mode | <p>You can select whether or not to do letterhead printing. If you select letterhead printing and duplex printing, the last sheet of a print job with an odd number of pages is printed on both sides.</p> <ul style="list-style-type: none"> <li>• Off</li> <li>• Auto Detect</li> <li>• On (Always)</li> </ul> <p> <b>Note</b></p> <ul style="list-style-type: none"> <li><input type="checkbox"/> Default: Off</li> <li><input type="checkbox"/> Duplex printing is canceled if the paper size does not allow it.</li> <li><input type="checkbox"/> If printing changes from single-sided to duplex during printing, the second and later copies with collate will all be duplex. If you want the second and later copies to be single-sided, select a paper size that does not allow duplex printing.</li> <li><input type="checkbox"/> When using letterheads, be careful how you orient the paper.</li> </ul> |

| Menu             | Description   |
|------------------|---|
| RAM Disk         | <p>If the optional hard disk drive is not installed, when executing PDF Direct Print set a value of 2 MB or higher.</p> <p>This menu appears only when the optional hard disk drive is not installed.</p> <ul style="list-style-type: none"> <li>• 0MB</li> <li>• 2MB</li> <li>• 4MB</li> <li>• 8MB</li> <li>• 16MB</li> </ul> <p> <b>Note</b></p> <ul style="list-style-type: none"> <li><input type="checkbox"/> Default: 4MB</li> <li><input type="checkbox"/> "16 MB" appears only when the memory unit is installed. See "<i>Memory Unit Type C (SDRAM Module)</i>", <i>Setup Guide</i> for optional memory unit installation.</li> </ul>   |
| Notify by E-Mail | <p>You can have error details sent to a preset e-mail address when an error occurs in the printer.</p> <ul style="list-style-type: none"> <li>• Off</li> <li>• On</li> </ul> <p> <b>Important</b></p> <ul style="list-style-type: none"> <li><input type="checkbox"/> After changing the setting, turn off the power of the main unit briefly, and then back on again.</li> </ul> <p> <b>Note</b></p> <ul style="list-style-type: none"> <li><input type="checkbox"/> Default: On</li> </ul>  |
| E-Mail Date      | <p>If there is no timeserver, set to "On" if mail without date information causes problems for the mail server. Through its software, e-mail sent by this device includes a date and time (based on a provisional date and time using January 1st of the year of manufacture as the initial date).</p> <ul style="list-style-type: none"> <li>• Off</li> <li>• On</li> </ul> <p> <b>Note</b></p> <ul style="list-style-type: none"> <li><input type="checkbox"/> Default: Off</li> <li><input type="checkbox"/> While the printer is On Line, press the <b>[Enter #]</b> key, and then press the <b>[Escape]</b> key, finally press the <b>[Menu]</b> key. You can access the "Menu Protect" menu on the panel display.</li> </ul> |

## Changing the System Menu

**1** Press [Menu].

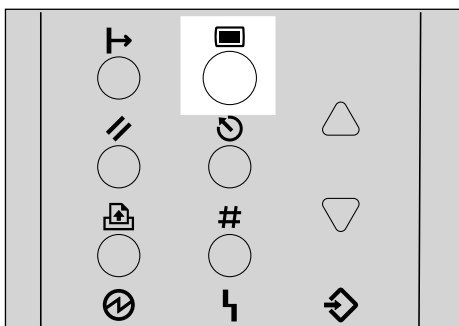

ZKGS020E

“Menu” appears on the panel display.

**2** Press [▲] or [▼] to display the “System” menu.

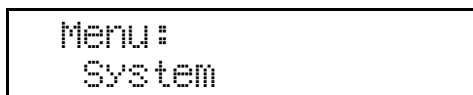

**3** Press [Enter #].

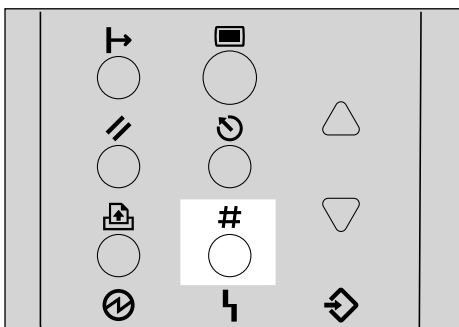

ZKGS021E

The following message appears on the panel display.

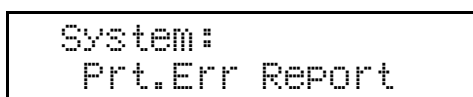

**4** Press [▲] or [▼] to display “Energy Saver”.

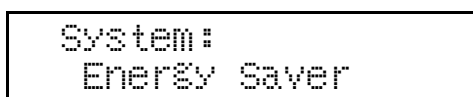



**5** Press **[Enter #]**.

The following message appears on the panel display.

```
Energy Saver:
E.Saver On/Off
```

**6** Press **[▲]** or **[▼]** to display "E. Saver Timer".

```
Energy Saver:
E. Saver Timer
```

**7** Press **[Enter #]**.

The following message appears on the panel display.

```
E. Saver Timer:
*30 minutes
```

**8** Press **[▲]** or **[▼]** to select how many minutes the printer waits before switching to Energy Saver mode.**9** Press **[Enter #]**.

The screen returns to step **6** in a few seconds.

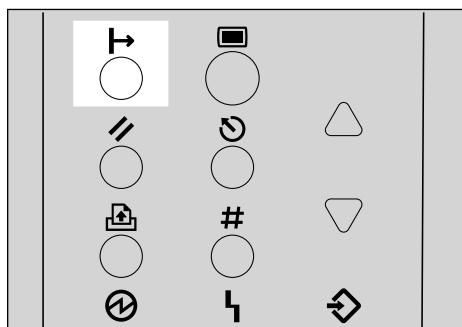
**10** Press **[On Line]**.

ZKGS022E

"Ready" appears on the panel display.

```
Ready
```

## Host Interface Menu



There are six menu items in the “Host Interface” menu.













- I/O Buffer
- I/O Timeout
- Network Setup
- IEEE 1394 Setup
- IEEE 802.11b
- USB Setting





---







### Host Interface Parameters











---



| Menu        | Description   |
|-------------|---|
| I/O Buffer  | <p>You can set the size of the I/O Buffer. Normally it is not necessary to change this setting.</p> <p>128 KB, 256 KB, 512 KB</p> <p> <b>Note</b></p> <p><input type="checkbox"/> Default: 128 KB</p>  |
| I/O Timeout | <p>You can set how many seconds the printer waits before ending a print job if more data is not received when using parallel interface and USB. If data from another port often appears in the middle of a print job, you should increase the timeout value.</p> <p>10 seconds, 15 seconds, 20 seconds, 25 seconds, 60 seconds</p> <p> <b>Note</b></p> <p><input type="checkbox"/> Default: 15 seconds</p> |

| Menu          | Description   |
|---------------|---|
| Network Setup | <p>Items Only appear in the Network Setup when the related options are installed.</p> <p> <b>Reference</b><br/>For more information about the "Network Setup", see "Configuring the Printer for the Network" in the Setup Guide.</p> <p> <b>DHCP</b><br/>You can set how the network interface board acquires TCP/IP settings.</p> <p> <b>Note</b><br/><input type="checkbox"/> Default: On</p> <p> <b>IP Address</b><br/>You can set the IP Address.</p> <p> <b>Limitation</b><br/><input type="checkbox"/> When DHCP is On, its setting cannot be changed. If you want to change the setting, make the setting for DHCP Off. Consult the network administrator for information about how to make the setting for the network.</p> <p> <b>Note</b><br/><input type="checkbox"/> Default: 011.022.033.044</p> <p> <b>Subnet Mask</b><br/>You can set the Subnet Mask.</p> <p> <b>Limitation</b><br/><input type="checkbox"/> When DHCP is On, its setting cannot be changed. If you want to change the setting, make the setting for DHCP Off. Consult the network administrator for information about how to make the setting for the network.</p> <p> <b>Note</b><br/><input type="checkbox"/> Default: All zero</p> <p> <b>Gateway Address</b><br/>You can set the Gateway Address.</p> <p> <b>Limitation</b><br/><input type="checkbox"/> When DHCP is On, its setting cannot be changed. If you want to change the setting, make the setting for DHCP Off. Consult the network administrator for information about how to make the setting for the network.</p> <p> <b>Note</b><br/><input type="checkbox"/> Default: All zero</p> |

| Menu          | Description   |
|---------------|---|
| Network Setup | <p>❖ <b>Frame Type (NW)</b><br/>                     You can set the Frame Type for NetWare.</p> <p> <b>Note</b><br/> <input type="checkbox"/> Default: Auto</p> <p>❖ <b>Active Protocol</b><br/>                     You can set the active protocol.<br/>                     TCP/IP, NetWare, NetBEUI, AppleTalk</p> <p> <b>Note</b><br/> <input type="checkbox"/> Default: All Active</p> <p>❖ <b>Ethernet</b><br/>                     You can select the speed of the network to which the printer is connected.<br/>                     Auto, 10 Mbps, 100 Mbps</p> <p> <b>Note</b><br/> <input type="checkbox"/> Default: Auto</p> <p>❖ <b>LAN Type</b><br/>                     You can select Ethernet or IEEE 802.11b for the LAN type.</p> <p> <b>Note</b><br/> <input type="checkbox"/> Default: Ethernet<br/> <input type="checkbox"/> Appears only when the optional 802.11b Interface Unit is installed.</p> |

| Menu                          | Description  |
|-------------------------------|--|
| IEEE 1394 Setup <sup>*1</sup> | <p>You can make settings for using IEEE 1394. This menu appears only when the optional IEEE 1394 board is installed.</p> <p> <b>Reference</b><br/>For more information about the "IEEE 1394 Setup", see "Configuring the Printer for the Network" in the Setup Guide.</p> <p>❖ <b>DHCP</b><br/>You can set the method the IEEE 1394 Interface Unit uses to acquire TCP/IP settings.</p> <p> <b>Note</b><br/><input type="checkbox"/> Default: On</p> <p>❖ <b>IP Address1394</b><br/>You can set the IP address for IEEE 1394 (IP over 1394).</p> <p> <b>Note</b><br/><input type="checkbox"/> Default: All zero</p> <p>❖ <b>Subnet Mask1394</b><br/>You can set the Subnet Mask for IEEE 1394 (IP over 1394).</p> <p> <b>Note</b><br/><input type="checkbox"/> Default: All zero</p> <p>❖ <b>IP over 1394</b><br/>You can activate IP over 1394.</p> <p> <b>Note</b><br/><input type="checkbox"/> Default: Active</p> <p>❖ <b>SCSI print</b><br/>You can activate SCSI print.</p> <p> <b>Note</b><br/><input type="checkbox"/> Default: Activate</p> <p>❖ <b>Bidi-SCSI print</b><br/>You can activate bidirectional transmission for SCSI print.</p> <p> <b>Note</b><br/><input type="checkbox"/> Default: Activate</p> |

| Menu            | Description   |
|-----------------|---|
| IEEE 802.11b *2 | <p>You can make settings for using the wireless LAN. This menu appears only when the optional IEEE 802.11b board is installed.</p> <p> <b>Reference</b><br/>                     For more information about the "IEEE 802.11b", see "Configuring the Printer for the Network" in the Setup Guide.</p> <p> <b>Comm. Mode</b><br/>                     You can set the transmission mode for IEEE 802.11b. 802.11b Ad hoc, Infrastructure, Ad hoc</p> <p> <b>Note</b><br/> <input type="checkbox"/> Default: 802.11b Ad hoc</p> <p> <b>Channel</b><br/>                     The selectable channels are 1-11 (Inch version) and 1-13 (Metric version).</p> <p> <b>Note</b><br/> <input type="checkbox"/> Default: 11</p> <p> <b>Trans. Speed</b><br/>                     You can set the transmission speed for IEEE 802.11b. Auto, 11 Mbps, 5.5 Mbps, 2 Mbps, 1 Mbps</p> <p> <b>Note</b><br/> <input type="checkbox"/> Default: Auto</p> <p> <b>SSID</b><br/>                     You can make settings for SSID in Infrastructure mode and 802.11 Ad hoc mode.</p> <p> <b>Limitation</b><br/> <input type="checkbox"/> Select "¥" if you want to enter "/" in the SSID. Also, "¥" appears when printing the configuration page, read it as "/".</p> <p> <b>Note</b></p> <ul style="list-style-type: none"> <li><input type="checkbox"/> Up to 32 ASCII characters in the range 0x20-0x7e can be used. The SSID setting is case-sensitive.</li> <li><input type="checkbox"/> An SSID value is automatically set to the nearest access point if the setting has not been made.</li> <li><input type="checkbox"/> If the setting has not been made for 802.11 Ad hoc mode, the same value for Infrastructure mode or an "ASSID" value is automatically set.</li> </ul> |

| Menu                        | Description   |
|-----------------------------|---|
| IEEE 802.11b * <sup>2</sup> | <p>◆ <b>WEP Setting</b><br/>You can set the code for IEEE 802.11b.</p> <p> <b>Note</b></p> <ul style="list-style-type: none"> <li><input type="checkbox"/> Default: Not Active</li> <li><input type="checkbox"/> You need to set the WEP code key from the network before making this setting. Without the key, transmission cannot be performed.</li> <li><input type="checkbox"/> Be sure to set the key before setting the code to "Active".</li> </ul> |
| USB Setting * <sup>3</sup>  | <p>You can set the transmission speed for USB.</p> <p> <b>Note</b></p> <ul style="list-style-type: none"> <li><input type="checkbox"/> Default: Auto</li> </ul>  |

\*<sup>1</sup> Appears only when the 1394 Interface Unit board is installed.

\*<sup>2</sup> Appears only when the 802.11b Interface Unit board is installed.

\*<sup>3</sup> While the printer is Online, press **[Enter #]**, and then press **[Escape]**. Finally, press **[Menu]**. You can access the "USB Setting" menu on the panel display.

## Changing the Host Interface Menu

6

**1** Press **[Menu]**.

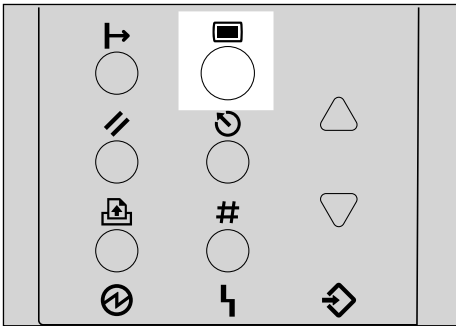

ZKGS020E

"Menu" appears on the panel display.

**2** Press **[▲]** or **[▼]** to display the "Host Interface" menu.



**3** Press **[Enter #]**.

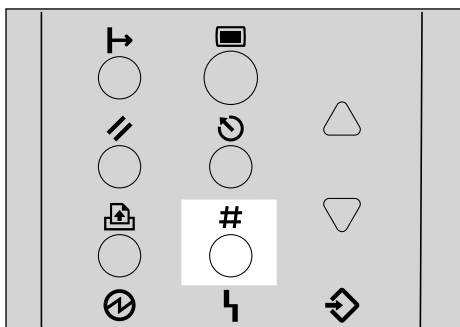

ZKGS021E

The following message appears on the panel display.

```
Host Interface:
I/O Buffer
```

**4** Press **[▲]** or **[▼]** to display "I/O Timeout".

```
Host Interface:
I/O Timeout
```

**5** Press **[Enter #]**.

The following message appears on the panel display.

```
I/O Timeout:
*15 seconds
```

**6** Press **[▲]** or **[▼]** to select how many minutes the printer waits before ending a print job.

**7** Press **[Enter #]**.

The screen returns to step **4** in a few seconds.



**8** Press **[On Line]**.

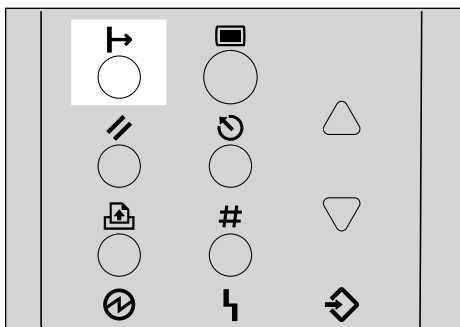

ZKGS022E

“Ready” appears on the panel display.











## PCL Menu



There are 11 menu items in the “PCL Menu” .

- Orientation
- Form Lines
- Font Source
- Font Number
- Point Size
- Font Pitch
- Symbol Set
- Courier Font
- Ext. A4 Width
- Append CR to LF
- Resolution

### PCL Parameters

| Menu        | Description   |
|-------------|---|
| Orientation | <p>You can set the page orientation.</p> <ul style="list-style-type: none"> <li>• Portrait</li> <li>• Landscape</li> </ul> <p> <b>Note</b></p> <p><input type="checkbox"/> Default: Portrait</p>   |
| Form Lines  | <p>You can set the number of lines per page.<br/>5-128</p> <p> <b>Note</b></p> <p><input type="checkbox"/> Default: 64 (Metric version), 60 (Inch version)</p>   |
| Font Source | <p>You can set the location of the default font.</p> <ul style="list-style-type: none"> <li>• Resident</li> <li>• RAM</li> <li>• HDD</li> <li>• Slot DIMM</li> </ul> <p> <b>Note</b></p> <p><input type="checkbox"/> Default: Resident</p> <p><input type="checkbox"/> "RAM" appears when fonts are installed in the memory unit.</p> <p><input type="checkbox"/> "HDD" appears when the optional hard disk drive is installed and fonts are installed in the hard disk. For optional hard disk drive installation, see “Hard Disk Drive Type 2600”, <i>Setup Guide</i>.</p> |

| Menu          | Description  |
|---------------|--|
| Font Number   | <p>You can set the ID of the default font you want to use.</p> <ul style="list-style-type: none"> <li>• 0 to 50 (for Internal)</li> <li>• 1 to downloaded number</li> </ul> <p> <b>Note</b></p> <p><input type="checkbox"/> Default: Internal</p> <p><input type="checkbox"/> Default: 0</p>  |
| Point Size    | <p>You can set the point size you want to use for the default font.<br/>4 to 999.75 by 0.25</p> <p> <b>Note</b></p> <p><input type="checkbox"/> Default: 12.00</p> <p><input type="checkbox"/> This setting is effective only for a variable-space font.</p>  |
| Font Pitch    | <p>You can set the number of characters per inch you want to use for the default font.<br/>0.44 to 99.99 by 0.01</p> <p> <b>Note</b></p> <p><input type="checkbox"/> Default: 10.00</p> <p><input type="checkbox"/> This setting is effective only for a fixed-space font.</p>  |
| Symbol Set    | <p>You can specify the set of print characters for the default font. The available options are as follows.</p> <p>Roman-8, ISO L1, ISO L2, ISO L5, PC-8, PC-8 D/N, PC-850, PC-852, PC8-TK, Win L1, Win L2, Win L5, Desktop, PS Text, VN Intl, VN US, MS Publ, Math-8, PS Math, VN Math, Pifont, Legal, ISO 4, ISO 6, ISO 11, ISO 15, ISO 17, ISO 21, ISO 60, ISO 69, Win 3.0</p> <p> <b>Note</b></p> <p><input type="checkbox"/> Default: Roman-8</p> |
| Courier Font  | <p>You can select a courier font type.</p> <ul style="list-style-type: none"> <li>• Regular</li> <li>• Dark</li> </ul> <p> <b>Note</b></p> <p><input type="checkbox"/> Default: Regular</p>   |
| Ext. A4 Width | <p>You can extend the width of the printable area for an A4 sheet leaving a narrow margin on the sides.</p> <p> <b>Note</b></p> <p><input type="checkbox"/> Default: Off</p>  |

| Menu            | Description  |
|-----------------|--|
| Append CR to LF | <p>By adding a CR code to each LF code, you can print text data clearly.</p> <ul style="list-style-type: none"> <li>• On</li> <li>• Off</li> </ul> <p> <b>Note</b><br/> <input type="checkbox"/> Default: Off</p> |
| Resolution      | <p>You can set the print resolution in dots per inch.</p> <ul style="list-style-type: none"> <li>• 300 dpi</li> <li>• 600 dpi</li> </ul> <p> <b>Note</b><br/> <input type="checkbox"/> Default: 600 dpi</p>       |

## Changing the PCL Menu

**1** Press [Menu].

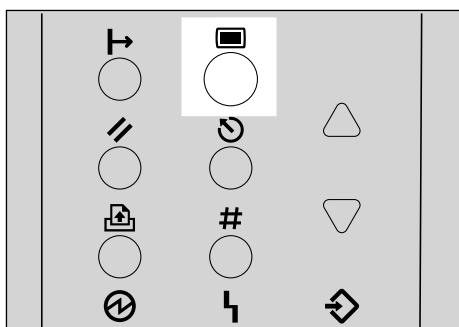

ZKGS020E

"Menu" appears on the panel display.

**2** Press [▲] or [▼] to display "PCL Menu", and then press [Enter #].

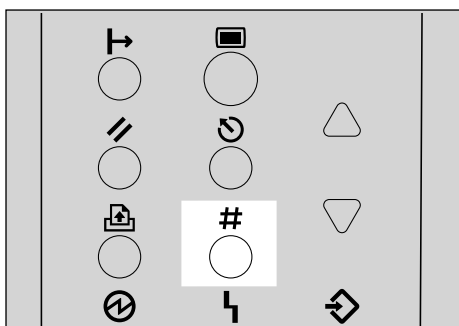

ZKGS021E

The following message appears on the panel display.

```
PCL Menu:
Orientation
```

**3** Press **[Enter #]**.



**4** Press **[▲]** or **[▼]** to select the orientation desired, and then press **[Enter #]**.  
Wait for a few seconds.

The screen returns to step **2** in a few seconds.

**5** Press **[On Line]**.

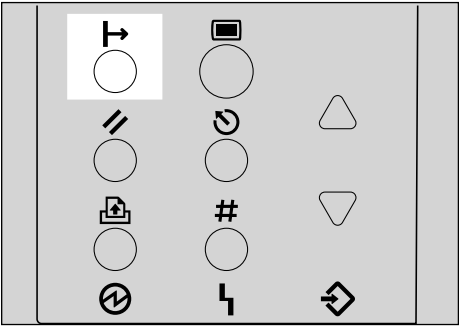

ZKGS022E

"Ready" appears on the panel display.





## PS Menu

There are two menu items in the “PS Menu” .

- Data Format
- Resolution

### PS Parameters

| Menu        | Description  |
|-------------|--|
| Data Format | <p>You can select the data format.</p> <ul style="list-style-type: none"> <li>• Binary Data</li> <li>• TBCP</li> </ul> <p> <b>Limitation</b></p> <ul style="list-style-type: none"> <li><input type="checkbox"/> This setting is effective when operating the machine with a parallel, USB or EtherTalk connection.</li> <li><input type="checkbox"/> When operating the machine with a parallel or USB connection, if binary data is sent from the printer driver, the print job is canceled.</li> <li><input type="checkbox"/> When operating the machine with an Ethernet connection, the print job is canceled under the following conditions; <ul style="list-style-type: none"> <li>• The printer driver data format is TBCP and the data format selected on the control panel is Binary Data.</li> <li>• The printer driver data format is binary and the data format selected on the control panel is TBCP.</li> </ul> </li> </ul> <p> <b>Note</b></p> <ul style="list-style-type: none"> <li><input type="checkbox"/> Default: Binary Data</li> </ul> |
| Resolution  | <p>You can select the resolution.</p> <ul style="list-style-type: none"> <li>• 300 dpi</li> <li>• 600 dpi</li> <li>• 1200 dpi</li> </ul> <p> <b>Note</b></p> <ul style="list-style-type: none"> <li><input type="checkbox"/> Default: 600 dpi</li> </ul>  |

## Changing the PS Menu

The following example describes how to change the setting for “TBCP”:

- 1 Press the **[Menu]** key.

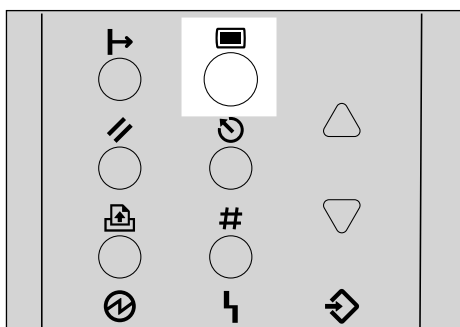

ZKGS020E

“Menu” appears on the display.

- 2 Press the **[▲]** or **[▼]** key to display “PS Menu”, and then press the **[Enter #]** key.

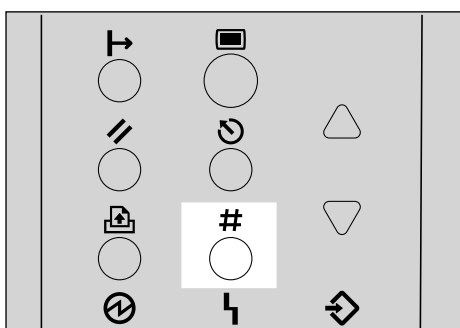

ZKGS021E

The following message appears on the display:

```
PS Menu:
Data Format
```

- 3 Press the **[Enter #]** key.

```
Data Format:
*Binary Data
```

- 4 Press the **[▲]** or **[▼]** key to select the TBCP desired, and then press the **[Enter #]** key. Wait for two seconds.

“PS Menu” appears on the display.

**5** Press the **[On Line]** key.

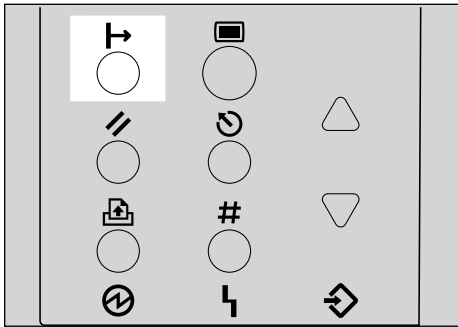

ZKGS022E

“Ready” appears on the display.



**6**





# PDF Menu

There are two menu items in the “PDF Menu” .

- PDF: Change PW
- Resolution

## PDF Parameters

| Menu           | Description  |
|----------------|--|
| PDF: Change PW | <p>Set <b>[Password to Open the Text File]</b> for the PDF file executing PDF Direct Print.</p> <ul style="list-style-type: none"> <li>• PDF Current PW</li> <li>• Enter new PW</li> </ul> <p> <b>Important</b></p> <p><input type="checkbox"/> A password can be set using on the Web Image Monitor, but in this case the password information is sent through the network. If security is a priority, set the password using this menu from the Control Panel.</p> <p> <b>Note</b></p> <p><input type="checkbox"/> Default: no password set.</p> |
| Resolution     | <p>You can select the resolution.</p> <ul style="list-style-type: none"> <li>• 300 dpi</li> <li>• 600 dpi</li> <li>• 1200 dpi</li> </ul> <p> <b>Note</b></p> <p><input type="checkbox"/> Default: 600 dpi</p>   |

## Changing the PDF Menu

**1** Press [Menu].

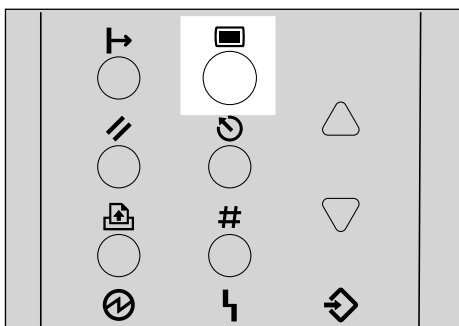

ZKGS020E

"Menu" appears on the panel display.

**2** Press [▲] or [▼] to display "PDF Menu", and then press [Enter #].

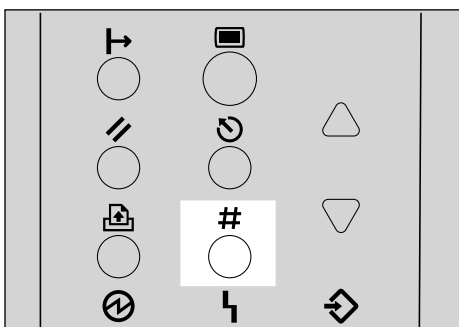

ZKGS021E

The following message appears on the panel display.

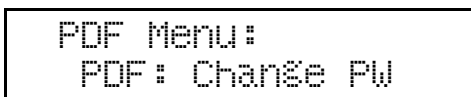

- 3** Press **[▲]** or **[▼]** to display "Resolution", and then press **[Enter #]**.

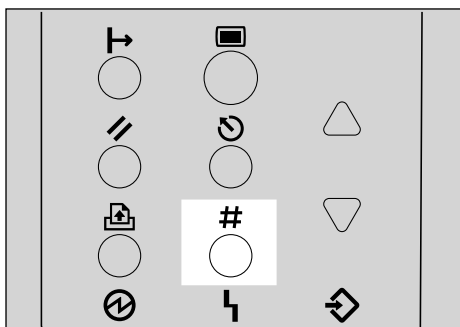

ZKGS021E

The following message appears on the panel display.

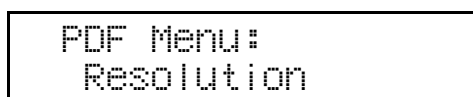

- 4** Press **[Enter #]**.

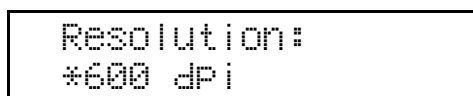

6

- 5** Press **[▲]** or **[▼]** to select the resolution desired, and then press **[Enter #]**.  
Wait for a few seconds.

The screen returns to step **2** in a few seconds.

- 6** Press **[On Line]**.

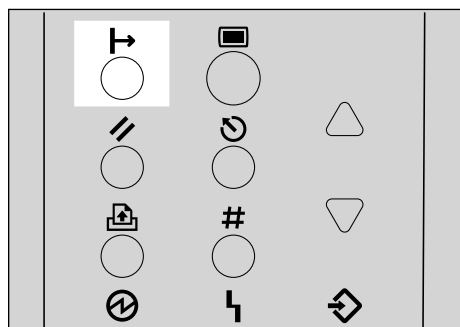

ZKGS022E

"Ready" appears on the panel display.

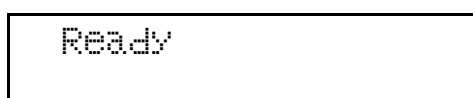

# Language Menu

You can select the language you use. Available language as are follows:  
 English, French, German, Italian, Spanish, Dutch, Swedish, Norwegian, Danish,  
 Finnish, Portuguese, Czech, Polish, Hungarian

**Note**

☐ Default: English

---

## Changing the Language Menu

---

You can change the language by the following procedures below.

**1** Press **[Menu]**.

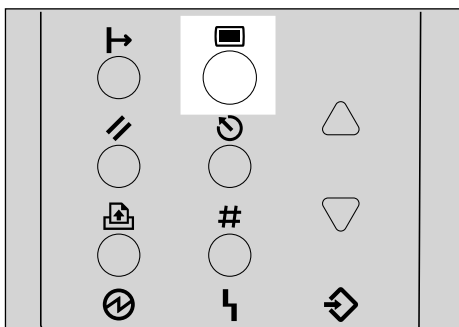

ZKGS020E

“Menu” appears on the panel display.

**2** Press **[▲]** or **[▼]** to display “Language” menu.

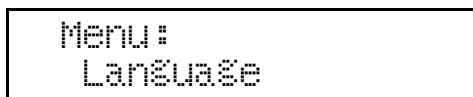

**3** Press **[Enter #]**.

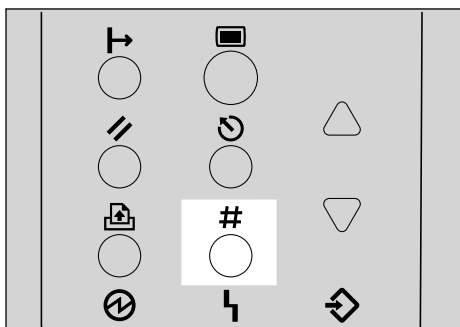

ZKGS021E

The following message appears on the panel display.

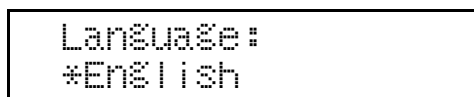

**4** Press **[▲]** or **[▼]** until the language you want to select appears on the panel display.

**5** Press **[Enter #]**. Wait for a few seconds.

The screen returns to step **2** in a few seconds.

**6** Press **[On Line]**.

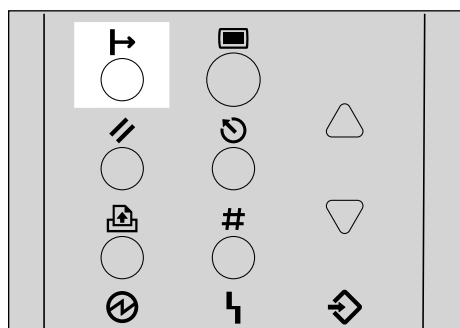

ZKGS022E

"Ready" appears on the panel display.





## Replacing Parts

The maintenance kit contains parts necessary for maintaining the printer. When “Replace Maintenance Kit” appears on the panel display, install the replacement parts included in the maintenance kit.

**⚠ WARNING:**

- *It is dangerous to handle the plug with wet hands. An electric shock might occur.*

**⚠ CAUTION:**

- *The inside of the machine could be very hot. Do not touch the parts with a label indicating "⚠" (means hot surface). Touching "⚠" (means hot surface) could result in a burn.*
- *When you pull the plug out of the socket, grip the plug to avoid damaging the cord and causing a fire or an electric shock.*
- *Be sure to turn off the printer and wait for about an hour before replacing parts. Not waiting for the printer to cool down can result in a burn.*





**📝 Note**

- ☐ If you dispose of the used parts yourself, dispose of them according to local regulations.

## MAINTENANCE KIT Type 600

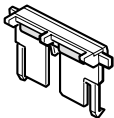
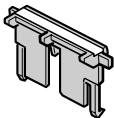
### Checking the contents of the box

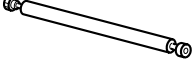
Check the contents of the box according to the following list. If one or more items are missing, contact your sales or service representative.

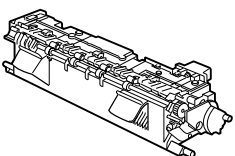
| Description   | Quantity |   |   |
|---|----------|---|---|
| Friction pad for the paper tray (Tray 1)              | 1 pc     |    | See p.180 "Replacing the Friction Pad".       |
| Friction pad for the Paper Feed Unit (Tray 2, 3)      | 2 pcs    |    |   |
| Paper feed roller for the paper tray (Tray 1)         | 1 pc     |   | See p.181 "Replacing the Paper Feed Rollers". |
| Paper feed roller for the Paper Feed Unit (Tray 2, 3) | 2 pcs    |  |   |
| Transfer roller                                       | 1 pc     |  | See p.183 "Replacing the Transfer Roller".    |
| Gloves  | 1 pair   |  |   |
| Fusing Unit   | 1 pc     |  | See p.185 "Replacing the Fusing Unit".        |



---

## Preparing to replace the parts

---

You should replace all the parts included in Maintenance Kit at the same time. Be sure to replace them in the following order:

### **1** Check the contents of the box for the following items:

- Friction pad for the paper tray (Tray 1)
- Friction pad for the Paper Feed Unit (Tray 2, 3)
- Paper feed roller for the paper tray (Tray 1)
- Paper feed roller for the Paper Feed Unit (Tray 2, 3)
- Transfer roller
- Fusing Unit
- Gloves

### **2** Confirm that the followings are true:

- The power switch is turned off.
- The power cord is unplugged from the wall outlet.
- The interface cable is unplugged from the printer.

### **Important**

- Wait about an hour after the printer is turned off to allow internal parts to cool down before replacing the Maintenance Kit.

## Replacing the Friction Pad

Replace all friction pad of the tray. There are two kinds of friction pads. One is for the paper tray (Tray 1), and the other are for the Paper Feed Unit(s) (Tray 2, 3). The following procedure shows how to replacing friction pad of the paper tray (Tray1).

**1** If the optional Duplex Unit, the Mailbox or the 1-bin Shift Sort Tray are installed, uninstall them from the printer.

**2** Lift the paper tray slightly then pull it out until it stops.

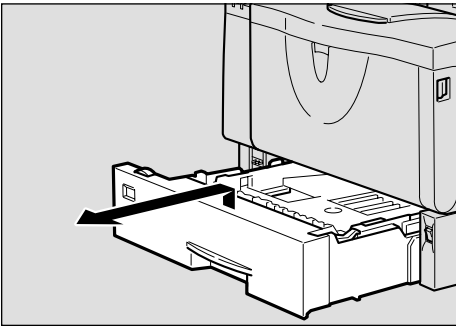

ZKGY430E

**3** While lifting the front side of the tray, pull it out of the printer.

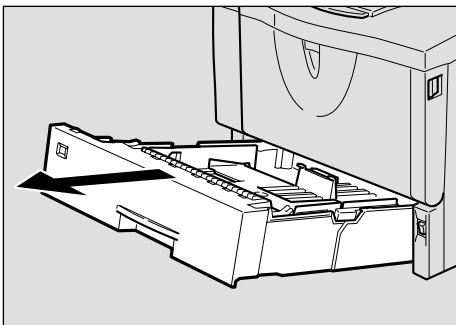

ZKGY140E

**4** Remove paper from the paper tray. Place the tray upside down on a flat surface.

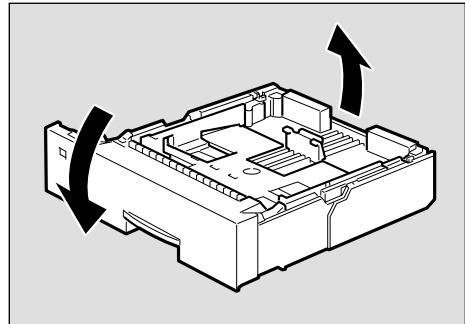

ZKGM160E

**5** Use a sharp-pointed item like a ball-point pen, to release the two catches that lock the friction pad.

 **Note**

- The friction pad may fall off when the catches are released. Place your hand over the friction pad while releasing the catches.
- The friction pad spring may come off. Be careful the spring does not fall off and become lost.
- The catches that lock the friction pad are located at the very back.

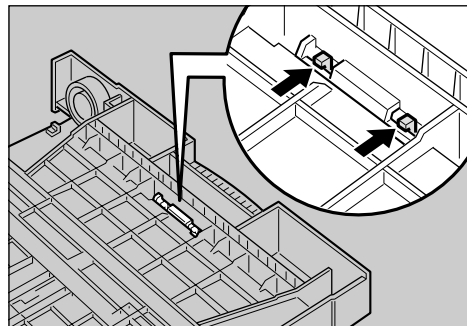

ZKGM170E

- 6** Return the paper tray to its original position, and remove the friction pad from the tray.

 **Note**

- The friction pad spring may come off. Be careful the spring does not fall off and become lost.

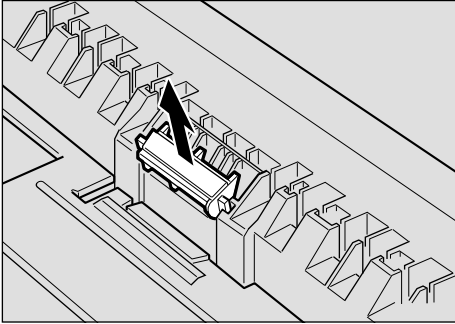

ZKGM180E

- 7** Insert the new friction pad in the paper tray.

Attach the center projection of the new friction pad to the spring and align the projection of both sides of the friction pad to the holes of the paper tray. Then push the friction pad as shown in the illustration until it clicks.

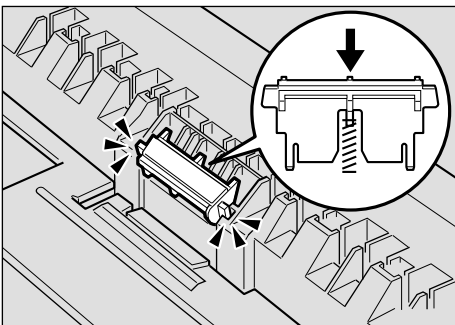

ZKGM190E

After pushing in the friction pad, try pushing it several times to check it is properly installed. If it jumps back into position due to the force of the spring, it is properly installed.

- 8** Push the friction pad until it locks securely.

- 9** If your printer is equipped with the optional Paper Feed Unit(s), follow the same procedure when replacing the friction pad.

## Replacing the Paper Feed Rollers

Replace all feed rollers including the printer and the optional Paper Feed Unit(s). The following procedure shows how to replacing the paper feed rollers of the printer.

**⚠ CAUTION:**

- When lifting the machine, use the inset grips on both sides. Otherwise the printer could break or cause injury if dropped.

- 1** If the optional Duplex Unit, the Mailbox or the 1-bin Shift Sort Tray are installed, uninstall them from the printer.

- 2** Move the printer to the edge of a sturdy and stable table or desk.

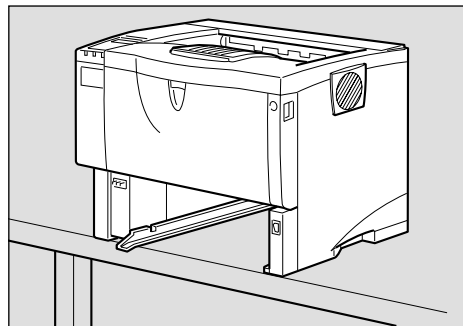

ZKGM110E

### Important

- ❑ Be sure to move the printer horizontally. Moving the printer facing up on down may cause the toner to scatter.
- ❑ Do not put the printer on an unstable or tilted surface.

### Note

- ❑ If the printer is equipped with the optional Paper Feed Unit, do not move the printer and the unit together, they are not securely attached.

- 3** Slide the green lock lever to the right (①), remove the paper feed roller (②).

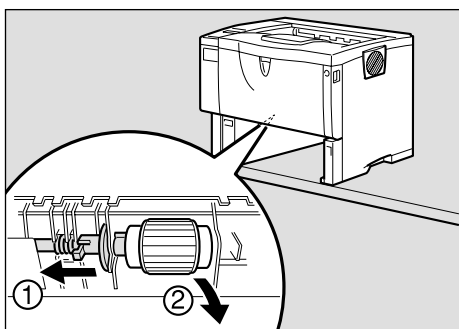

ZKGM120E

- 4** While sliding the green lock lever to the right (①), set the new roller (②). After that, return the green lock lever to its original position (③).

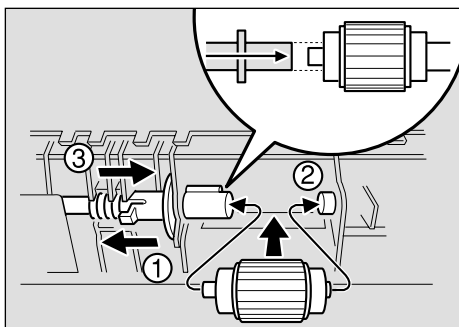

ZKGM130E

### Note

- ❑ Confirm that the green lock lever secures the roller correctly by checking if the new roller rotates smoothly.

- 5** If the printer is equipped with the optional Paper Feed Unit(s), follow the same procedure when replacing the paper feed roller.

If you installed two Paper Feed Units, also replace both paper feed rollers.

- 6** Place paper in the paper trays and additional removed paper trays. Lift the front of the tray, and slide it carefully into the printer until it stops.

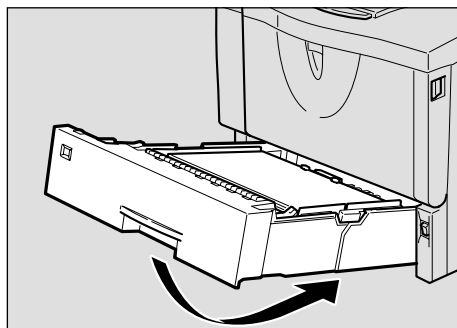

ZKGY150E

## Replacing the Transfer Roller

- 1** Open the front cover by pushing the front cover release button.

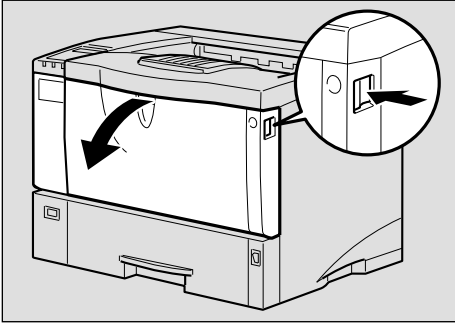

ZKGH120E

- 2** Pull the toner cartridge out of the printer, while lifting the front side.

**Note**

- Be sure to place the used cartridge on the level place.

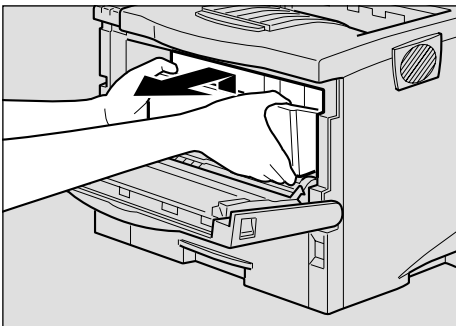

ZKGT110E

- 3** To avoid making your hands dirty with toner from the transfer roller, wear the gloves included in the maintenance kit.

- 4** Hold the lock levers ("●" parts), and pull them.

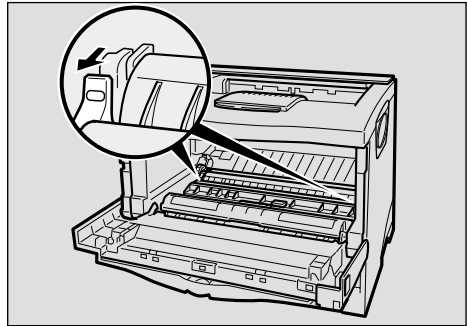

ZKGM201E

- 5** Hold the green parts of the roller on both sides, and remove the roller from the printer as shown in the illustration.

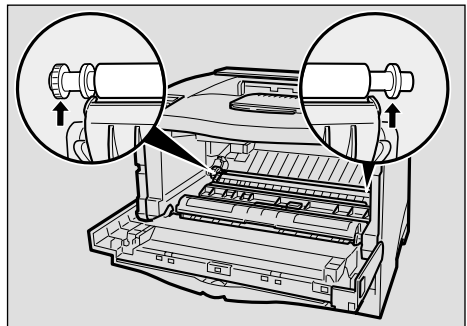

ZKGM210E

- 6** Insert the new transfer roller on the socket with the gear of the roller positioned on the left.

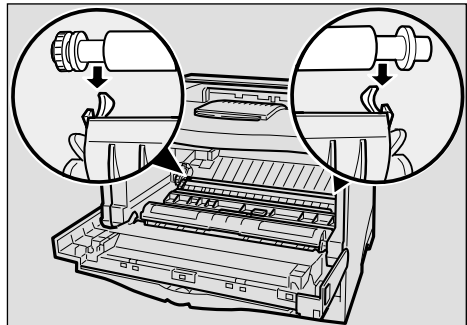

ZKGM220E

### ⚠ Important

- ❑ Do not insert the roller on the back of the socket, or the printer might be damaged.
- ❑ Insert the metallic part of the roller on the socket. If you insert the sponge part of the roller, the roller might be damaged.

- 7** Push down the green parts of both sides of the printer until it clicks as shown in the illustration.

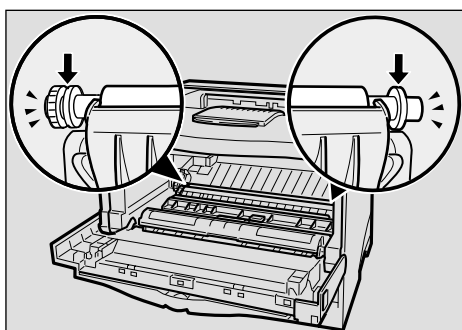

ZKGM221E

7

### 📌 Note

- ❑ When the transfer roller is set, the transfer roller cover will return to its original position automatically.

- 8** Holding the grips of the toner cartridge, insert it into the printer until it stops.

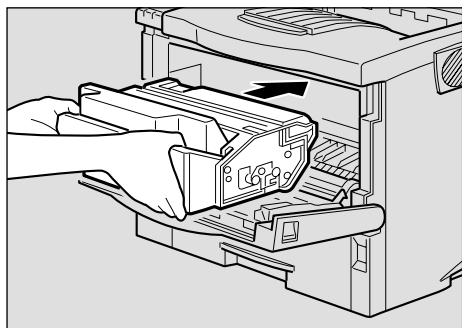

ZKGT120E

- 9** Lower the toner cartridge when it touches the back.

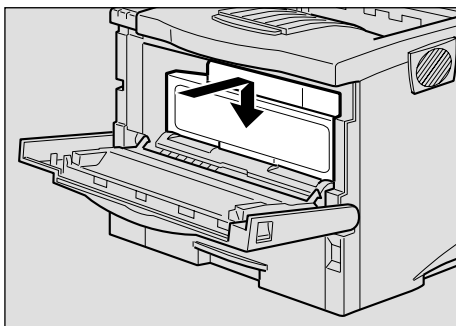

ZKGT140E

- 10** Close the front cover.

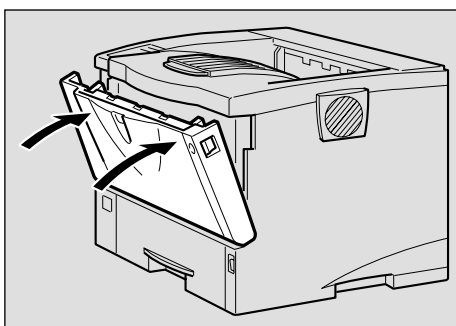

ZKGH130E

- 11** Take the gloves off and go to p.185 "Replacing the Fusing Unit".

## Replacing the Fusing Unit

### ⚠ CAUTION:

- The fusing unit becomes very hot. When installing the new fusing unit, turn off the printer and wait about an hour. After that, install the new fusing unit. Not waiting for the unit to cool down can result in a burn.

**1** If the rear cover is attached to the printer, remove it.

#### 📌 Note

- Proceed to step **2** if the optional Duplex Unit was removed in step **1**, "Replacing the Paper Feed Rollers".

**1** Open the rear cover by pushing the two knobs.

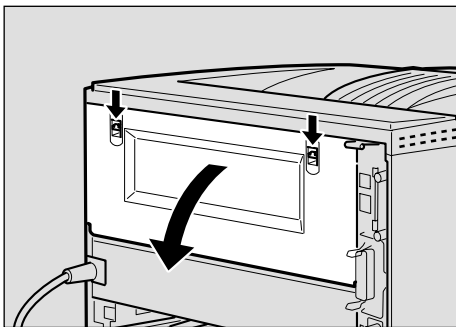

ZKGX210E

**2** Remove the rear cover in a horizontal direction.

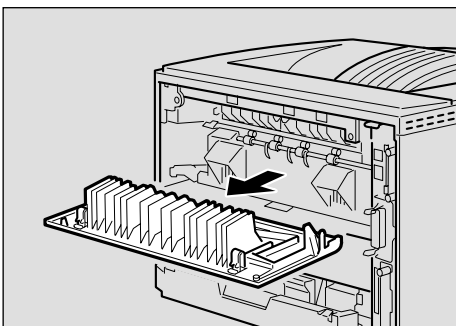

ZKGX220E

**2** Lift the lock levers of the fusing unit as shown in the illustration.

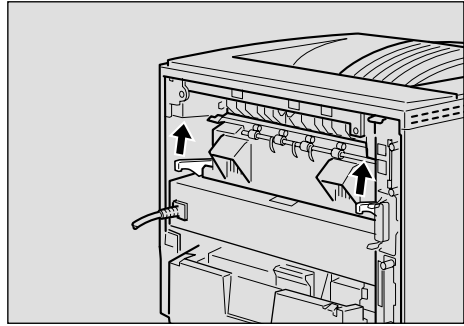

ZKGX222E

**3** Pull the fusing unit out.

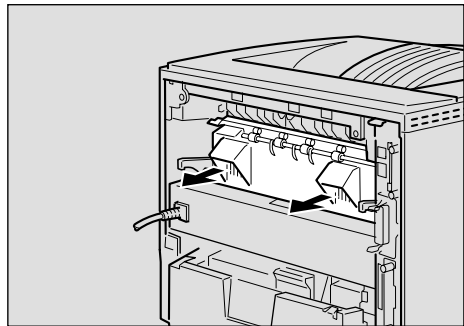

ZKGX223E

**4** Pull out the pins on both sides of the new fusing unit.

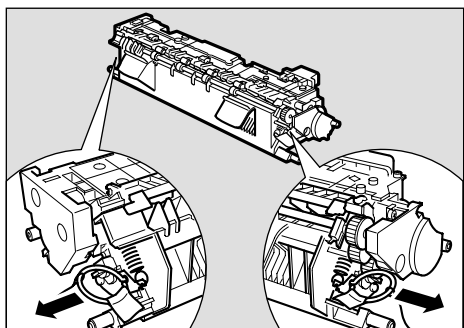

ZKGM010E

**5** Replace the new fusing unit into the printer.

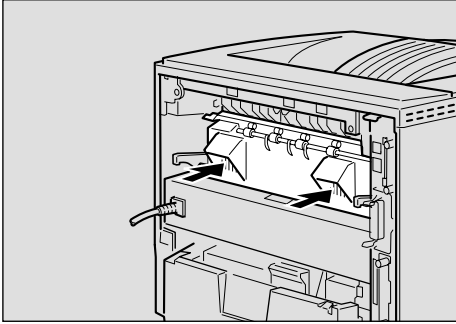

ZKGX224E

**6** Push the lock levers of the fusing unit down until it clicks.

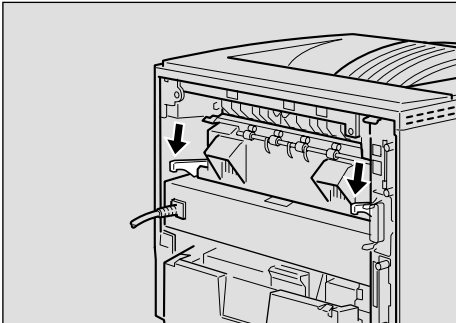

ZKGX225E

**1** Insert the rear cover to the inside grooves on both sides of the printer in a horizontal direction.

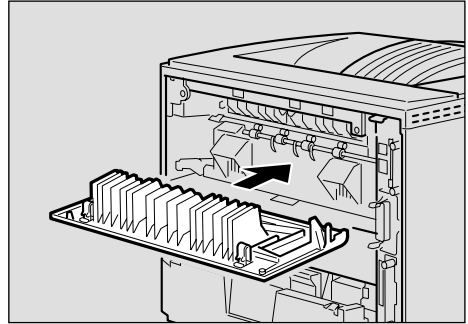

ZKGX221E

**2** Close the rear cover.

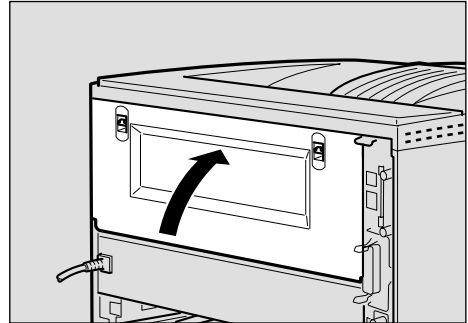

ZKGX211E

**7** Reinstall the rear cover removed in step **1**.

**Note**

- Proceed to step **8** if the optional Duplex Unit was removed in step **1**, "Replacing the Paper Feed Rollers".

**8** Reinstall the optional Duplex Unit if it was removed in step **1**, "Replacing the Paper Feed Rollers".

**Reference**

See p.194 "Moving and Transporting the Printer".

**9** Print a configuration page to confirm that the printer works properly.

**Reference**

For more information about printing the configuration page, see p.130 "List/Test Print Menu".



# Collate and Shift Collate

## Reference

For more information about collate and shift collate, see the printer driver's Help file.

## Collate

Outputs can be assembled as sets in sequential order.

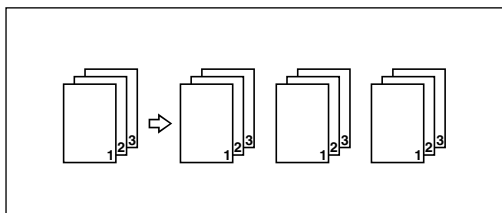

## Shift Collate

The shift tray moves backward or forward each time the copies of one set or those of each job are delivered, and makes the next copy to shift when delivered to differentiate each set or jobs.

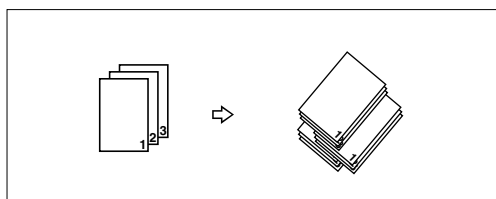

## Limitation

- You must install an additional Memory Unit or the optional hard disk drive to use the collate function.
- The numbers of pages that can be collated after installing an additional Memory Unit are indicated below.

| Total Memory Size             | Approximate Number of Pages <sup>*1</sup> |
|-------------------------------|---|
| 128 MB (additional of 64 MB)  | 200 pages                                 |
| 192 MB (additional of 128 MB) | 1,000 pages                               |
| 320 MB (additional of 256 MB) |   |

<sup>\*1</sup> Based on A4 , 5% chart and 600 dpi. Page numbers vary according to resolution and data.

- When the optional hard disk drive installed, maximum number of pages that can be collated is about 1,000, including Sample Print and Locked Print pages.

## Note

- When using PostScript 3, if you select Upper Tray as an output tray, it is shift collated automatically. When using RPCS, you can select collate function.

# Spool Printing

With spool printing, the whole data of a print job is saved in the Printer Hard Disk before printing. To use this function, set it from the menu. See p.148 “System Menu”.

## Important

- Do not turn off the printer or the computer when a print job is being spooled and the **Data In** indicator is blinking. If you do, the print job will remain in the Printer Hard Disk and be printed when the printer is turned on.

## Limitation

- Spool printing does not appear unless the optional Hard Disk Drive is installed.
- Data received in a protocol other than LPD, IPP, or SMB cannot be spooled.
- Up to 150 jobs (approximately 500 MB) can be spooled at once.
- When spool printing is on, the size of a single print job cannot exceed 500 MB.
- When sending spooled print jobs from more than one computer at the same time, up to 10 LPR jobs, one IPP job, and 10 SMB jobs can be spooled. Jobs exceeding the maximum number cannot be spooled. Wait until the number of spooled print jobs falls below the maximum before adding jobs.

## Note

- When "On" is selected, the first print will take time.

## Confirm or delete the spooled job from a Web browser.

The spooled job can be viewed or deleted from a Web browser. Open a Web browser, and then enter the printer's IP address as the URL to display the top page. In the administrator mode, click **[Job]** on the menu displayed in the left frame. A submenu will then appear. Click **[Spool Printing]** on the **[Printer]** menu. A list of spooled jobs is displayed. To delete a job, select the check box of the job you want to delete, and then click **[Delete]**.

# Precautions when using Windows Server 2003

---

## Precautions when using the Terminal Server mode

---

Certain printer driver functions are disabled. Disabled functions are displayed in gray. When using all printer driver functions, use Windows Server 2003 in normal mode.

# Memory Capacity and Paper Size

The following tables show the typical memory requirements of the RPCS printer language. Memory requirements depend on your print data and printing environment, such as the "Memory Priority" setting or total memory size that the printer has available. The print mode also effects whether the print job will equally completed.

## Setting of the "Frame Priority"

| Paper Size              | Memory Capacity | Resolution (dpi) |           |               |
|-------------------------|-----------------|------------------|-----------|---------------|
|                         |                 | 300 x 300        | 600 x 600 | 1,200 x 1,200 |
| A5                      | 64 MB           | ○                | ○         | ○             |
|                         | 128 MB          | ○                | ○         | ○             |
|                         | 192 MB          | ○                | ○         | ○             |
|                         | 320 MB          | ○                | ○         | ○             |
| B5                      | 64 MB           | ○                | ○         | ○             |
|                         | 128 MB          | ○                | ○         | ○             |
|                         | 192 MB          | ○                | ○         | ○             |
|                         | 320 MB          | ○                | ○         | ○             |
| A4<br>Letter (8 1/2x11) | 64 MB           | ○                | ○         | ○*            |
|                         | 128 MB          | ○                | ○         | ○             |
|                         | 192 MB          | ○                | ○         | ○             |
|                         | 320 MB          | ○                | ○         | ○             |
| B4                      | 64 MB           | ○                | ○         | ○*            |
|                         | 128 MB          | ○                | ○         | ○             |
|                         | 192 MB          | ○                | ○         | ○             |
|                         | 320 MB          | ○                | ○         | ○             |
| A3                      | 64 MB           | ○                | ○         | ○*            |
|                         | 128 MB          | ○                | ○         | ○             |
|                         | 192 MB          | ○                | ○         | ○             |
|                         | 320 MB          | ○                | ○         | ○             |
| Legal (8 1/2x14)        | 64 MB           | ○                | ○         | ○*            |
|                         | 128 MB          | ○                | ○         | ○             |
|                         | 192 MB          | ○                | ○         | ○             |
|                         | 320 MB          | ○                | ○         | ○             |

| Paper Size                         | Memory Capacity | Resolution (dpi) |           |               |
|------------------------------------|-----------------|------------------|-----------|---------------|
|                                    |                 | 300 x 300        | 600 x 600 | 1,200 x 1,200 |
| 11 x 17                            | 64 MB           | ○                | ○         | ○*            |
|                                    | 128 MB          | ○                | ○         | ○             |
|                                    | 192 MB          | ○                | ○         | ○             |
|                                    | 320 MB          | ○                | ○         | ○             |
| Maximum custom size (216 x 432 mm) | 64 MB           | ●                | ●         | ●*            |
|                                    | 128 MB          | ●                | ●         | ●             |
|                                    | 192 MB          | ●                | ●         | ●             |
|                                    | 320 MB          | ●                | ●         | ●             |
| 8K<br>(267x390mm)                  | 64 MB           | ○                | ○         | ○*            |
|                                    | 128 MB          | ○                | ○         | ○             |
|                                    | 192 MB          | ○                | ○         | ○             |
|                                    | 320 MB          | ○                | ○         | ○             |
| 16K<br>(195x267mm)                 | 64 MB           | ○                | ○         | ○             |
|                                    | 128 MB          | ○                | ○         | ○             |
|                                    | 192 MB          | ○                | ○         | ○             |
|                                    | 320 MB          | ○                | ○         | ○             |

○

Means that the print job is supported by simplex and duplex printing.

○\*

Means it might be impossible to print images complex data with duplex printing. Even with simple data, the number of pages printed with duplex printing might be limited.

## Setting of the “Font Priority”

| Paper Size              | Memory Capacity | Resolution (dpi)      |                       |                         |
|-------------------------|-----------------|-----------------------|-----------------------|-------------------------|
|                         |                 | 300 x 300             | 600 x 600             | 1,200 x 1,200           |
| A5                      | 64 MB           | <input type="radio"/> | <input type="radio"/> | <input type="radio"/>   |
|                         | 128 MB          | <input type="radio"/> | <input type="radio"/> | <input type="radio"/>   |
|                         | 192 MB          | <input type="radio"/> | <input type="radio"/> | <input type="radio"/>   |
|                         | 320 MB          | <input type="radio"/> | <input type="radio"/> | <input type="radio"/>   |
| B5                      | 64 MB           | <input type="radio"/> | <input type="radio"/> | <input type="radio"/>   |
|                         | 128 MB          | <input type="radio"/> | <input type="radio"/> | <input type="radio"/>   |
|                         | 192 MB          | <input type="radio"/> | <input type="radio"/> | <input type="radio"/>   |
|                         | 320 MB          | <input type="radio"/> | <input type="radio"/> | <input type="radio"/>   |
| A4<br>Letter (8 1/2x11) | 64 MB           | <input type="radio"/> | <input type="radio"/> | <input type="radio"/> * |
|                         | 128 MB          | <input type="radio"/> | <input type="radio"/> | <input type="radio"/>   |
|                         | 192 MB          | <input type="radio"/> | <input type="radio"/> | <input type="radio"/>   |
|                         | 320 MB          | <input type="radio"/> | <input type="radio"/> | <input type="radio"/>   |
| B4                      | 64 MB           | <input type="radio"/> | <input type="radio"/> | <input type="radio"/> * |
|                         | 128 MB          | <input type="radio"/> | <input type="radio"/> | <input type="radio"/>   |
|                         | 192 MB          | <input type="radio"/> | <input type="radio"/> | <input type="radio"/>   |
|                         | 320 MB          | <input type="radio"/> | <input type="radio"/> | <input type="radio"/>   |
| A3                      | 64 MB           | <input type="radio"/> | <input type="radio"/> | <input type="radio"/> * |
|                         | 128 MB          | <input type="radio"/> | <input type="radio"/> | <input type="radio"/>   |
|                         | 192 MB          | <input type="radio"/> | <input type="radio"/> | <input type="radio"/>   |
|                         | 320 MB          | <input type="radio"/> | <input type="radio"/> | <input type="radio"/>   |
| Legal (8 1/2x14)        | 64 MB           | <input type="radio"/> | <input type="radio"/> | <input type="radio"/> * |
|                         | 128 MB          | <input type="radio"/> | <input type="radio"/> | <input type="radio"/>   |
|                         | 192 MB          | <input type="radio"/> | <input type="radio"/> | <input type="radio"/>   |
|                         | 320 MB          | <input type="radio"/> | <input type="radio"/> | <input type="radio"/>   |
| 11 x 17                 | 64 MB           | <input type="radio"/> | <input type="radio"/> | <input type="radio"/> * |
|                         | 128 MB          | <input type="radio"/> | <input type="radio"/> | <input type="radio"/>   |
|                         | 192 MB          | <input type="radio"/> | <input type="radio"/> | <input type="radio"/>   |
|                         | 320 MB          | <input type="radio"/> | <input type="radio"/> | <input type="radio"/>   |

| Paper Size                         | Memory Capacity | Resolution (dpi) |           |               |
|------------------------------------|-----------------|------------------|-----------|---------------|
|                                    |                 | 300 x 300        | 600 x 600 | 1,200 x 1,200 |
| Maximum custom size (216 x 432 mm) | 64 MB           | ●                | ●         | ●*            |
|                                    | 128 MB          | ●                | ●         | ●             |
|                                    | 192 MB          | ●                | ●         | ●             |
|                                    | 320 MB          | ●                | ●         | ●             |
| 8K (267x390mm)                     | 64 MB           | ○                | ○         | ○*            |
|                                    | 128 MB          | ○                | ○         | ○             |
|                                    | 192 MB          | ○                | ○         | ○             |
|                                    | 320 MB          | ○                | ○         | ○             |
| 16K (195x267mm)                    | 64 MB           | ○                | ○         | ○*            |
|                                    | 128 MB          | ○                | ○         | ○             |
|                                    | 192 MB          | ○                | ○         | ○             |
|                                    | 320 MB          | ○                | ○         | ○             |

○

Means that the print job is supported by simplex and duplex printing.

○\*

Means it might be impossible to print images complex data with duplex printing. Even with simple data, the number of pages printed with duplex printing might be limited.

●\*

Means it might be impossible to print images complex data with printing. Even with simple data, the number of pages printed with printing might be limited.

# Moving and Transporting the Printer

## ⚠ CAUTION:

- When lifting the machine, use the inset grips on both sides. Otherwise the printer could break or cause injury if dropped.
- When you move the printer, remember to unplug the power cord from the wall outlet to avoid a fire or an electric shock.
- When you pull out the plug from the socket, grip the plug to avoid damaging the cord and causing a fire or an electric shock.

Repack the printer in its original packing materials for transporting.

## 🔧 Important

- ❑ Be sure to disconnect all cables from the printer before transporting it.
- ❑ The printer is a precision piece of machinery. Take care to avoid damage during shipment.

## Moving the Printer

### ⚠ CAUTION:

- The machine weight is approximately 20 kg (44.1 lb. bond).
- When lifting the machine, use the inset grips on both sides. Otherwise the printer could break or cause injury if dropped.
- Before moving the machine, unplug the power cord from the outlet. If the cord is unplugged abruptly, it could become damaged. Damaged plugs or cords can cause an electrical or fire hazard.

## Moving the printer in the short distance

**1** Confirm that the followings are true:

- The power switch is turned off.
- The power cord is unplugged from the wall outlet.
- The interface cable is unplugged from the printer.

**2** If you installed external options, remove them.

## Removing the Mailbox or the 1-bin Shift Sort Tray

The following procedure shows how to remove the Mailbox as an example.

**1** Pull all the upper trays out.

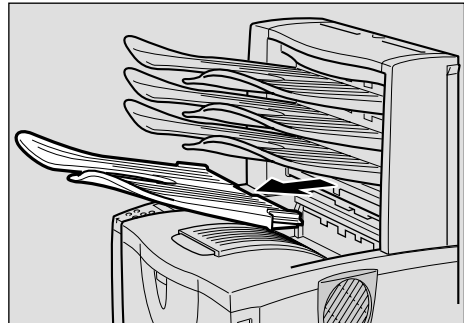

ZKGY371E

**2** While pushing the lock buttons (①), pull the Mailbox out (②).

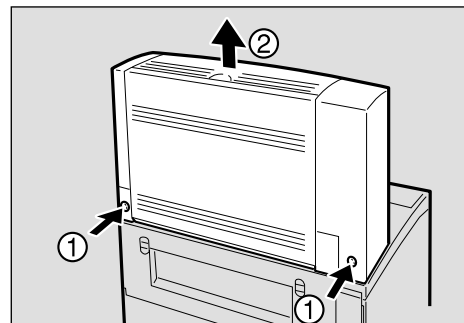

ZKGX470E



## Removing the Duplex Unit

- 1 Push down the lever on right side of the Duplex Unit (①) and pull it out until it stops (②).

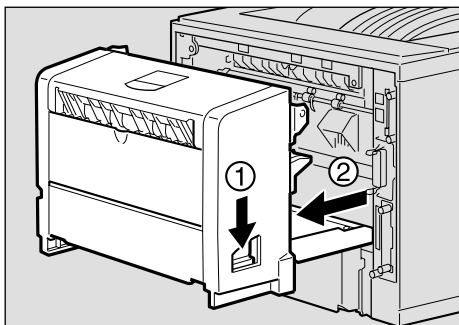

ZKGY320E

- 2 Push the under board levers (①) and pull the Duplex Unit out of the printer (②).

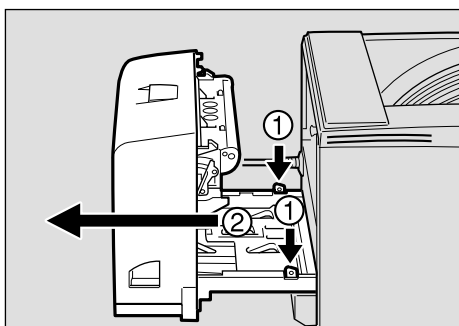

ZKGY450E

- 3 Be sure to close the Bypass Tray and the front cover.

- 4 Lift the printer and move it to the place where you want to install it.

### ⚠ CAUTION:

- When lifting the machine, use the inset grips on both sides. Otherwise the printer could break or cause injury if dropped.

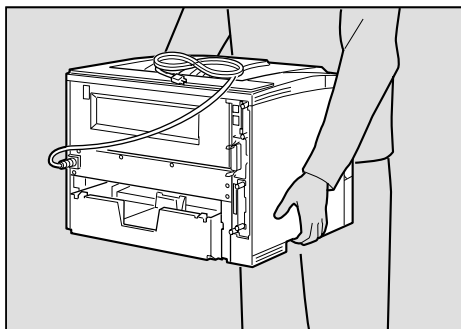

ZKGH221E

### ⚠ Important

- Be sure to move the printer horizontally. Moving the printer facing up on down may cause the toner to scatter.
- If the Paper Feed Unit(s) is installed, detach and move the printer separately. Never move the printer with the Paper Feed Unit(s) attached.

# Specifications

---

## Mainframe

---

### ❖ Configuration:

Desktop

### ❖ Print Process:

Laser beam scanning & Electrophotographic printing

Dual component toner development

### ❖ Printing Speed:

Maximum 32 pages per minute (A4☐, 8<sup>1</sup>/<sub>2</sub> × 11☐)

#### Note

☐ Continuous printing on sheets with a width of 230 mm or smaller may decrease the printing speed depending on the temperature control of the fusing unit.

### ❖ Interface:

Standard 36-pin printer cable and a parallel port on the host computer  
IEEE 1284 I/F (Compatible, ECP, Nibble)

- Do not use a cable more than 2.5 meters (8.2 feet) long.
- USB 2.0
- Bidirectional IEEE1284
- 10/100Base-TX

### ❖ Resolution:

1,200 × 1,200 dpi (PCL 6, RPCS, PS, PDF)

600 × 600 dpi (PCL 6, PCL 5e, RPCS, PS, PDF)

300 × 300 dpi (PCL 5e, PDF)

### ❖ Printer Language:

PCL 6 (XL) , PCL 5e, RPCS, Adobe PostScript 3

### ❖ Fonts:

**PCL 6, PCL 5e**

Agfa Font Manager 35 Intellifonts, 10 TrueType fonts, and 1 bitmap font  
Font Manager available, plus 31 additional fonts.

**PostScript, PDF**

136 fonts (Type 2:24, Type 14:112)

### ❖ Paper size:

See p.37 "Paper and Other Media Supported by This Printer"

### ❖ Paper Weight:

See p.37 "Paper and Other Media Supported by This Printer"

❖ **Power Source:**

220 - 240 V, 50/60 Hz, 4.5 A or more

❖ **Power Consumption:**

|              |               |
|--------------|---------------|
| Maximum      | 850 W or less |
| Printing     | 620 W or less |
| Energy Saver | 6.5 W         |

❖ **Noise Emission <sup>\*1</sup>:****Sound Power Level**

|                 | Mainframe only |
|-----------------|----------------|
| During Printing | 67 dB (A)      |
| Stand-by        | 40 dB (A)      |

**Sound Pressure level <sup>\*2</sup>**

|                 | Mainframe only |
|-----------------|----------------|
| During Printing | 55 dB (A)      |

<sup>\*1</sup> The following measurements are actual values made in accordance with ISO7779.

<sup>\*2</sup> Measured at the position of a bystander.

❖ **Dimensions: <sup>\*1</sup>**

|                                  | Width                | Depth                | Height               |
|----------------------------------|----------------------|----------------------|----------------------|
| Printer only (tray not extended) | 478 mm (18.4 inches) | 437 mm (17.2 inches) | 343 mm (13.5 inches) |
| Printer only (tray extended)     | 478 mm (18.4 inches) | 572 mm (22.6 inches) | 343 mm (13.5 inches) |
| With one optional feed unit      | 478 mm (18.4 inches) | 437 mm (17.2 inches) | 473 mm (18.6 inches) |
| With two optional feed units     | 478 mm (18.4 inches) | 437 mm (17.2 inches) | 603 mm (23.7 inches) |

<sup>\*1</sup> Measurement conditions: With paper tray, Bypass Tray and output tray extension closed.

❖ **Weight:**

Approximately 20 kg (44.1 lb. bond) (toner cartridge and power cord included)

❖ **Warm-up Time:**

Less than 19 seconds (23°C, 73F)

### ❖ Paper Capacity:

|  |  |
|--|--|
| Standard paper tray                    | 500 sheets <sup>*1</sup> (80 g/m <sup>2</sup> , 20 lb.bond)    |
| Bypass Tray <sup>*2</sup>              | 100 sheets <sup>*1</sup> (80g/m <sup>2</sup> , 20 lb.bond)     |
| Optional Paper Feed Unit × 2           | 500 sheets × 2 <sup>*1</sup> (80g/m <sup>2</sup> , 20 lb.bond) |
| Optional Envelope Feeder <sup>*3</sup> | 60 envelopes <sup>*4</sup>                                     |

<sup>\*1</sup> Paper weight: 60 – 105 g/m<sup>2</sup> (16 – 28 lb. bond)

<sup>\*2</sup> You can load up to 10 envelopes (55 – 157 g/m<sup>2</sup>, 14 – 42 lb. bond) at the same time.

<sup>\*3</sup> To use the Envelope Feeder Unit, the optional Paper Feed Unit is required. The paper tray of the feed unit can be replaced with the Envelope Feeder Unit.

<sup>\*4</sup> For more information about envelopes, see p.45 “Types of Paper and Other Media”.

### ❖ Paper Output Capacity:

250 sheets (80 g/m<sup>2</sup>, 20 lb. bond)

### ❖ Memory:

Standard 64 MB, up to 320 MB (with the optional Memory Unit)

### ❖ Network :

**Topology:** Ethernet (10BaseT/100BaseTX)

**Protocol:** TCP/IP, NetBEUI, IPX/SPX, AppleTalk

### ❖ Optional Equipment:

**Common for the Basic model printer and the Network standard model printer**

- Paper Feed Unit Type 600
- Envelope Feeder Type 2600
- 1-bin Shift Sort Tray Type 2600
- CS380 (Mailbox)
- AD410 (Duplex Unit)
- Memory Unit Type C 64 MB
- Memory Unit Type C 128 MB
- Memory Unit Type C 256 MB
- Hard Disk Drive Type 2600
- 1394 Interface Unit Type 4510
- 802.11b Interface Unit Type A
- Bluetooth Interface Unit Type 2045

---

## Options

---

---

### Paper Feed Unit Type 600

---

- ❖ **Dimensions (W×D×H):**  
468 × 410 × 130 mm (18.4 × 14.8 × 5.1 inches)  
(without pins on the unit)
- ❖ **Paper Weight:**  
60 – 105 g/m<sup>2</sup> (16 – 28 lb. bond)
- ❖ **Paper Size:**  
See p.37 “Paper and Other Media Supported by This Printer”.

---

### Envelope Feeder Type 2600

---

- ❖ **Dimensions (W×D×H):**  
468 × 410 × 130 mm (18.4 × 16.1 × 5.1 inches)
- ❖ **Paper Weight:**  
72 – 90 g/m<sup>2</sup> (19 – 24 lb. bond)
- ❖ **Paper Size:**  
See p.37 “Paper and Other Media Supported by This Printer”.

---

### AD410 (Duplex Unit)

---

- ❖ **Dimensions (W×D×H):**  
419 × 378 × 257 mm (16.5 × 14.9 × 10.2 inches)
- ❖ **Paper Size:**  
See p.37 “Paper and Other Media Supported by This Printer”.
- ❖ **Paper Weight:**  
60 – 105 g/m<sup>2</sup> (17 – 28 lb. bond)
- ❖ **Weight:**  
6 kg (13.2 lb. bond)

---

## 1-bin Shift Sort Tray Type 2600

---

- ❖ **Dimensions (W × D × H):**  
465 × 395 × 160 mm (18.3 × 15.6 × 6.3 inches)
- ❖ **Paper Size:**  
See p.37 “Paper and Other Media Supported by This Printer”.
- ❖ **Paper Weight:**  
60 – 105 g/m<sup>2</sup> (16 – 28 lb. bond)
- ❖ **Stack Capacity:**  
250 sheets / bin (80 g/m<sup>2</sup>, 20 lb. bond)
- ❖ **Weight:**  
3.5 kg (7.7 lb. bond)

---

## CS380 (Mailbox)

---

- ❖ **Dimensions (W × D × H):**  
465 × 395 × 285 mm (18.3 × 15.6 × 11.2 inches)
- ❖ **Paper Size:**  
See p.37 “Paper and Other Media Supported by This Printer”.
- ❖ **Paper Weight:**  
60 – 105 g/m<sup>2</sup> (16 – 28 lb. bond)
- ❖ **Stack Capacity:**  
50 sheets / bin (80 g/m<sup>2</sup>, 20 lb. bond)
- ❖ **Weight:**  
5.5 kg (12.1 lb. bond)

---

## Hard Disk Drive Type 2600

---

- ❖ **Storage Capacity (Formatted):**  
6 GB  
You can install PostScript fonts with this optional Hard Disk Drive. With a Macintosh, types of fonts supported are PostScript Type 1 and PostScript Type 2. To download them, use PS Utility for Mac.

---

**Memory Unit Type C (64 MB/128 MB/256 MB)**

---

- ❖ **Module Type:**  
SO-DIMM (Small Outline Dual-in-line Memory Module)
- ❖ **Memory Type:**  
SDRAM (Synchronous Dynamic RAM)
- ❖ **Number of Pins:**  
144 pins

---

**1394 Interface Unit Type 4510**

---

- ❖ **Transmission Spec.:**  
IEEE 1394
- ❖ **Device Class:**  
SCSI print, IP over 1394
- ❖ **Interface Connector:**  
IEEE 1394 (6 pins × 2)
- ❖ **Required cable:**  
1394 interface cable (6 pins × 4 pins, 6 pins × 6 pins)
- ❗ **Important**
  - You cannot plug devices together to create loops.
  - Do not use a cable more than 4.5 meters (14.8 feet) long.
- ❖ **Connectable number of device in a bus:**  
Maximum 63
- ❖ **Allowed cable hops in a bus:**  
Maximum 16
- ❖ **Power supply:**  
Nonpower supply  
Cable Power repeated (IEEE 1394a-2000 compliant)

---

## 802.11b Interface Unit Type A (R-WL11)

---

### ❖ **Transmission Spec.:**

Based on IEEE 802.11b (Wireless LAN)

### ❖ **Protocol:**

TCP/IP, NetBEUI, IPX/SPX, AppleTalk

### **Note**

SmartNetMonitor and Web Image Monitor are supported.

### ❖ **Data Transfer Speed:**

Auto select from below speed

1 Mbps, 2 Mbps, 5.5 Mbps, 11 Mbps

### ❖ **Frequency Range:**

- Inch version:  
2412-2464 Mhz (1-11 channels)
- Metric version:  
2412-2472 Mhz (1-13 channels)

### ❖ **Transmittable Distance:**

1 Mbps 400 m <sup>\*1</sup>  
2 Mbps 270 m <sup>\*1</sup>  
5.5 Mbps 200 m <sup>\*1</sup>  
11 Mbps 140 m <sup>\*1</sup>

<sup>\*1</sup> These figures are a guideline for outdoor use. In general, the transmittable distance indoors is 10-100 m, depending on the environment.

### ❖ **Transmission Mode:**

ad hoc mode and infrastructure mode



---

## Bluetooth Interface Unit Type 2045

---

**❖ Supported Profiles:**

SPP (Serial Port Profile)  
HCRP (Hardcopy Cable Replacement Profile)  
BIP (Basic Imaging Profile)

**❖ Frequency Range:**

2 GHz ISM band

**❖ Data Transmission Speed:**

732 kbps

** Note**

- The transmission speed is adjusted according to factors such as the distance and obstacles between the devices, radio signal condition and Bluetooth™ adaptor.

**❖ Maximum Range:**

10 m

# Consumables

**⚠ CAUTION:**

- *Our products are engineered to meet the highest standards of quality and functionality. When purchasing expendable supplies, we recommend using only those specified by an authorized dealer.*

❖ **Toner Cartridge**

|                 |  |
|-----------------|--|
|                 | Printable number of pages per cartridge * <sup>1</sup> |
| Toner Cartridge | 20,000 pages   |

\*<sup>1</sup> A4, 3% test chart

**📝 Note**

- The actual number of printed pages you get from a particular toner cartridge depends on the type and size of paper you are using, the contents of your print images, and printing environment conditions. All this means that a toner cartridge might require replacement sooner than the normal life described above.
- The number of printable pages that can be expected from the starter toner cartridge included in the printer is about 10,000 pages (A4, 3% chart).

❖ **Maintenance Kit**

**MAINTENANCE KIT TYPE 600**

It is required to change the maintenance kit after every 90,000 pages have been printed. However, it may be necessary to change the parts earlier depending on their operating period.

---

# Information about Installed Software

---

---

## expat

---

Expat(Version 1.1). Copyright 1998, 1999 James Clark. All rights reserved.

- The software installed on this product includes the expat application software Version 1.1 (hereinafter "expat 1.1").
- The product manufacturer has not made any modification to the source code of the expat 1.1.
- The product manufacturer provides warranty and support to the software of the product including the expat 1.1 and the product manufacturer makes Mr. James Clark, the initial developer of the expat 1.1, free from these obligations.
- The expat 1.1 is made available under Mozilla Public License Version 1.1 (hereinafter "MPL 1.1"), and controller software of the product equals the Larger Work as defined in MPL 1.1. The software of this product except the expat 1.1 is licensed to the product manufacturer under separate agreement(s).
- The source code of the expat 1.1 is available at:  
[ftp://ftp.jclark.com/pub/xml/expat1\\_1.zip](ftp://ftp.jclark.com/pub/xml/expat1_1.zip)
- MPL 1.1 is also available at:  
<http://www.mozilla.org/MPL/MPL-1.1.html>
- Information relating to the expat 1.1 is available at:  
<http://www.jclark.com/xml/expat.html>

---

## JPEG LIBRARY

---

- The software installed on this product is based in part on the work of the Independent JPEG Group.

---

## NetBSD

---

Copyright Notice of NetBSD

For all users to use this product:

This product contains NetBSD operating system:

For the most part, the software constituting the NetBSD operating system is not in the public domain; its authors retain their copyright.

The following text shows the copyright notice used for many of the NetBSD source code. For exact copyright notice applicable for each of the files/binaries, the source code tree must be consulted.

A full source code can be found at <http://www.netbsd.org/>.

Copyright Copier 1999, 2000 The NetBSD Foundation, Inc.

All rights reserved.

Redistribution and use in source and binary forms, with or without modification, are permitted provided that the following conditions are met:

- ① Redistributions of source code must retain the above copyright notice, this list of conditions and the following disclaimer.
- ② Redistributions in binary form must reproduce the above copyright notice, this list of conditions and the following disclaimer in the documentation and/or other materials provided with the distribution.
- ③ All advertising materials mentioning features or use of this software must display the following acknowledgment:  
This product includes software developed by the NetBSD Foundation, Inc. and its contributors.
- ④ Neither the name of The NetBSD Foundation nor the names of its contributors may be used to endorse or promote products derived from this software without specific prior written permission.

THIS SOFTWARE IS PROVIDED BY THE NETBSD FOUNDATION, INC. AND CONTRIBUTORS "AS IS" AND ANY EXPRESS OR IMPLIED WARRANTIES, INCLUDING, BUT NOT LIMITED TO, THE IMPLIED WARRANTIES OF MERCHANTABILITY AND FITNESS FOR A PARTICULAR PURPOSE ARE DISCLAIMED. IN NO EVENT SHALL THE FOUNDATION OR CONTRIBUTORS BE LIABLE FOR ANY DIRECT, INDIRECT, INCIDENTAL, SPECIAL, EXEMPLARY, OR CONSEQUENTIAL DAMAGES (INCLUDING, BUT NOT LIMITED TO, PROCUREMENT OF SUBSTITUTE GOODS OR SERVICES; LOSS OF USE, DATA, OR PROFITS; OR BUSINESS INTERRUPTION) HOWEVER CAUSED AND ON ANY THEORY OF LIABILITY, WHETHER IN CONTRACT, STRICT LIABILITY, OR TORT (INCLUDING NEGLIGENCE OR OTHERWISE) ARISING IN ANY WAY OUT OF THE USE OF THIS SOFTWARE, EVEN IF ADVISED OF THE POSSIBILITY OF SUCH DAMAGE.

7

---

### Authors Name List

---

All product names mentioned herein are trademarks of their respective owners. The following notices are required to satisfy the license terms of the software that we have mentioned in this document:

- This product includes software developed by the University of California, Berkeley and its contributors.
- This product includes software developed by Jonathan R. Stone for the NetBSD Project.
- This product includes software developed by the NetBSD Foundation, Inc. and its contributors.
- This product includes software developed by Manuel Bouyer.
- This product includes software developed by Charles Hannum.

- This product includes software developed by Charles M. Hannum.
- This product includes software developed by Christopher G. Demetriou.
- This product includes software developed by Tools GmbH.
- This product includes software developed by Terrence R. Lambert.
- This product includes software developed by Adam Glass and Charles Hannum.
- This product includes software developed by Theo de Raadt.
- This product includes software developed by Jonathan Stone and Jason R. Thorpe for the NetBSD Project.
- This product includes software developed by the University of California, Lawrence Berkeley Laboratory and its contributors.
- This product includes software developed by Christos Zoulas.
- This product includes software developed by Christopher G. Demetriou for the NetBSD Project.
- This product includes software developed by Paul Kranenburg.
- This product includes software developed by Adam Glass.
- This product includes software developed by Jonathan Stone.
- This product includes software developed by Jonathan Stone for the NetBSD Project.
- This product includes software developed by Winning Strategies, Inc.
- This product includes software developed by Frank van der Linden for the NetBSD Project.
- This product includes software developed for the NetBSD Project by Frank van der Linden
- This product includes software developed for the NetBSD Project by Jason R. Thorpe.
- The software was developed by the University of California, Berkeley.
- This product includes software developed by Chris Provenzano, the University of California, Berkeley, and contributors.

# INDEX

---

1394 interface cable, 201  
1394 Interface Unit Type 4510, 201  
1-bin Shift Sort Tray Type 2600, 200

## A

---

AD410 (Duplex Unit), 199  
adhesive labels, 45  
Adjusting the image density, 117  
Adjusting the Registration, 118  
Append CR to LF, 164  
Auto Continue, 148

## B

---

Bluetooth Interface Unit Type 2045, 203  
Bypass size, 126

## C

---

Collate, 187  
Config. Page, 130, 133  
Config.P/Er.Log, 130  
Control Panel Lock  
    *Locking the Panel*, 140  
Copies, 148  
Courier Font, 164  
CS380 (Mailbox), 200  
Curl Prevention, 137

## D

---

Data In indicator, 94  
Def.Print Lang., 148  
Duplex, 148

## E

---

Edge-Edge Print, 148  
Edge Smoothing, 148  
E-Mail Date, 148  
Energy Saver, 148  
Envelope Feeder Type 2600, 199  
envelopes, 46  
envelopes, loading, 58  
error, 75  
Error indicator, 93  
Error Log, 130  
Escape key, 125  
Ext. A4 Width, 164

## F

---

Font Number, 164  
Font Pitch, 164  
fonts, 196  
Font Source, 164  
Form Lines, 164  
friction pad, 180  
friction pad, cleaning, 113  
fusing unit, 185

## H

---

Hard Disk Drive Type 2600, 200  
HDD Format, 137  
Hex Dump, 130  
Host Interface, 124, 156

## I

---

IEEE 1394 Setup, 156  
IEEE 802.11b, 156  
Image density, 137  
I/O Buffer, 156  
I/O Timeout, 156

## J

---

Job Separation, 148

## K

---

Key Repeat, 137

## L

---

Language, 124, 174  
Letterhead Mode, 148  
List/Test Print, 124, 130  
List/Test Print Parameters, 130  
Locked Print, 68, 124

## M

---

Macintosh  
    *uninstall, PostScript*, 36  
Maintenance, 124, 137  
MAINTENANCE KIT Type 600, 178  
media, 37  
memory, 190, 198  
Memory Overflow, 148  
Memory Unit Type C  
    (64 MB/128 MB/256 MB), 201  
Memory Usage, 148  
menu, accessing, 124  
Menu Chart, 121  
Menu key, 124  
Menu List, 130  
Menu Protect, 137, 140  
messages, 75  
misfeed, 101

## N

---

Network, 198  
Network Printing Guide, 2  
Network Setup, 156  
Nortify by E-Mail, 148

## O

---

OHP transparencies, 45  
On Line indicator, 93  
On Line key, 93, 125  
options, 198, 199  
Orientation, 164  
Output Tray, 148

## P

---

Page Size, 148  
panel display, messages, 75  
Panel Lock, 140  
Panel Protect  
    *Locking the Panel*, 140  
paper, 37  
paper feed roller, 181  
paper feed roller, cleaning, 114  
Paper Feed Unit Type 600, 199  
Paper Input, 124, 126  
paper, loading, 49  
paper, sizes, types, 37  
Paper type, 126  
Parallel cable, 196  
PCL 5e  
    *Windows 2000, uninstalling*, 31  
    *Windows 95/98/Me, uninstalling*, 31  
    *Windows NT 4.0, uninstalling*, 32  
    *Windows XP/Server 2003, uninstalling*, 31  
PCL 6  
    *Windows 2000, uninstalling*, 31  
    *Windows 95/98/Me, uninstalling*, 31  
    *Windows NT 4.0, uninstalling*, 32  
    *Windows XP/Server 2003, uninstalling*, 31  
PCL Config.Page, 130  
PCL Menu, 124, 164  
PDF Config.Page, 130  
PDF Menu, 124, 171  
plain paper, 45  
Point Size, 164  
PostScript  
    *Macintosh, uninstall*, 36  
    *Windows 2000, uninstalling*, 35  
    *Windows 95/98/Me, uninstalling*, 35  
    *Windows NT 4.0, uninstalling*, 36  
    *Windows XP/Server 2003, uninstalling*, 35  
Ppr.Size Error, 137  
Precautions when using the Terminal  
    Server mode  
        *Windows Server 2003*, 189  
Precautions when using Windows Server 2003  
    *Windows Server 2003*, 189  
Printer Lang., 148  
Printer Reference, 2  
Prt. Err Report, 148  
PS Font List, 130  
PS Menu, 124, 168

## Q

---

Quick Installation Guide, 2

## R

---

RAM Disk, 148

Registration, 137

registration roller, cleaning, 116

Resolution, 164

RPCS

*Windows 2000, uninstalling, 33*

*Windows 95/98/Me, uninstalling, 33*

*Windows NT 4.0, uninstalling, 34*

*Windows XP/Server 2003, uninstalling, 33*

## S

---

Sample Print, 63, 124

SDRAM, 198, 201

Setup Guide, 2

Shift Collate, 187

specifications, 196

Spool Printing, 148

Sub Paper Size, 148

Symbol Set, 164

System, 124, 148

## T

---

toner cartridge, replacing, 110

Toner Saving, 148

transfer roller, 183

Tray Locking, 126

Tray Paper Size, 126

Tray Priority, 126

troubleshooting, 75

## U

---

Unit Of Measure, 148

USB Setting, 156

## W

---

Windows 2000

*PCL 5e, uninstalling, 31*

*PCL 6, uninstalling, 31*

*PostScript, uninstalling, 35*

*printer properties, PCL, 7*

*printer properties, PostScript, 21*

*printer properties, RPCS, 14*

*RPCS, uninstalling, 33*

Windows 95/98/Me

*PCL 5e, uninstalling, 31*

*PCL 6, uninstalling, 31*

*PostScript, uninstalling, 35*

*printer properties, PCL, 5*

*printer properties, PostScript, 19*

*printer properties, RPCS, 12*

*RPCS, uninstalling, 33*

Windows 95/98/Me, Windows 2000,

Windows XP/Server 2003, Windows NT 4.0

*canceling a job, 27*

Windows NT 4.0

*PCL 5e, uninstalling, 32*

*PCL 6, uninstalling, 32*

*PostScript, uninstalling, 36*

*printer properties, PCL, 10*

*printer properties, PostScript, 24*

*printer properties, RPCS, 17*

*RPCS, uninstalling, 34*

Windows XP/Server 2003

*PCL 5e, uninstalling, 31*

*PCL 6, uninstalling, 31*

*PostScript, uninstalling, 35*

*printer properties, PCL, 7*

*printer properties, PostScript, 21*

*printer properties, RPCS, 14*

*RPCS, uninstalling, 33*

WL.LAN Defaults, 137

WL.LAN Signal, 137





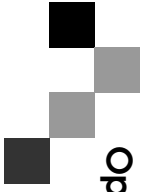

**Operating Instructions    Printer Reference**